

**A lexicalist and construction-based approach  
to coordinations**

Anne Abeillé

LLF, Université Paris 7  
abeille@linguist.jussieu.fr

Proceedings of the HPSG03 Conference  
Michigan State University, East Lansing

Stefan Müller (Editor)

2003

CSLI Publications

<http://csli-publications.stanford.edu/>

## Abstract

Leaving aside elliptical coordinations, it is striking that no agreement has been reached on the structure of basic coordinate constructions. We propose that:

- coordinate constructions are structurally asymmetric : the conjunction makes a subconstituent with one of the conjuncts.
- such constituents can have several functions: coordinate daughter, adjunct daughter or main clause.

In order to show that some conjuncts should be analysed as adjuncts, we focus on asymmetric cases of coordination, in which the order of the conjuncts cannot be reversed, taking examples from French, Welsh and Korean.

We present an HPSG analysis which treats the "coordinating" conjunctions as "weak" heads, with lexical subtypes, and coordinate phrases as multi-headed constructions, with different subtypes.

## Introduction<sup>1</sup>

Most recent work on the syntax of coordination in HPSG (e.g. Levy and Pollard 2001, Sag 2002), and LFG (Dalrymple & Kaplan 2000), has been devoted to feature passing and feature resolution, while most has been devoted to the structure of coordinated phrases in derivational approaches (Munn 1992, Johanessen 1998). Leaving aside elliptical coordinations, it is striking that no agreement has been reached on the structure of basic coordinate constructions. We propose that:

- coordinate constructions are structurally asymmetric : the conjunction makes a subconstituent with one of the conjuncts.
- this *Conj X* constituent can have several functions, including adjunct.

We first discuss the basic structures which have been proposed, and then focus on asymmetric "coordinations", in which the order of the conjuncts cannot be reversed, taking examples from French, Welsh and Korean, and show that they are best analysed as adjuncts.

We then provide an HPSG analysis for French "coordinating" conjunctions and for the different constructions involving phrases introduced by such conjunctions.

### 1. Different structures proposed for coordination

The syntactic analysis of coordinate phrases has often been debated. We distinguish two independent questions:

- is the structure hierarchical (A) or flat (B) ?
- do the daughters have the same function or not ?

---

<sup>1</sup> Many thanks to Bob Borsley, Danièle Godard, Liliane Tasmowski, for fruitful discussions, and to the Paris 7 reading group on coordination especially François Mouret, Jesse Tseng and Olivier Bonami.

Let us start with the structural issue. Some versions of A is adopted in Sag et al 1985, Johannessen 1998 a.o, while B is used in Dalrymple and Kaplan 2000, Sag and Wasow 1999, a.o.

Hierarchical structure (A)      Flat structure (B)

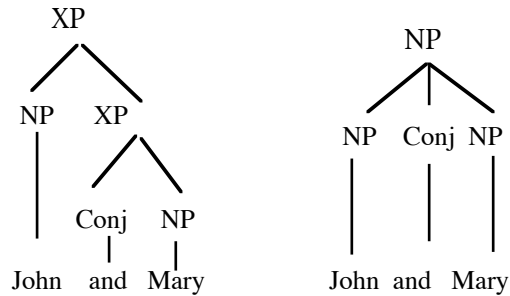

As observed by Ross (1967), Munn (1992) a.o., the main problem with flat structure B is that it ignores the fact that Conj-XP combinations are well-formed phrases outside coordinations (cf Huddleston and Pullum 2002):

- (1) a And Mary ?  
b Nor do the French
- (2) a John bought a book yesterday, and a newspaper  
b They allowed the others a second chance, but not me  
c Did the boss tell you that or her secretary ?

Structure B also cannot account for break asymmetry (cf Ross 1967):

- (3) a I will see John # and Mary  
b \* I will see John and # Mary

Third, there are languages where the conjunction is an affix on one of the conjuncts (cf (5) below, and Borsley 1994). We thus conclude that the conjunction forms a subconstituent with one of the conjuncts (cf Ross 1967, Sag et al 1985, Borsley 1994, Munn 1992...), and that structure B has to be rejected.

Let us now consider the functional issue. Symmetric analyses, such as (1), assign the same function to all conjuncts, while asymmetric ones (2 and 3) identify one of the conjuncts as the head.

- 1- head-head      2- spec -head-complement      3- head-adjunct  
 Sag et al 1985,      Kayne 1994      Munn 1992, 2000  
 Gazdar et al 1985 Johannessen 1999

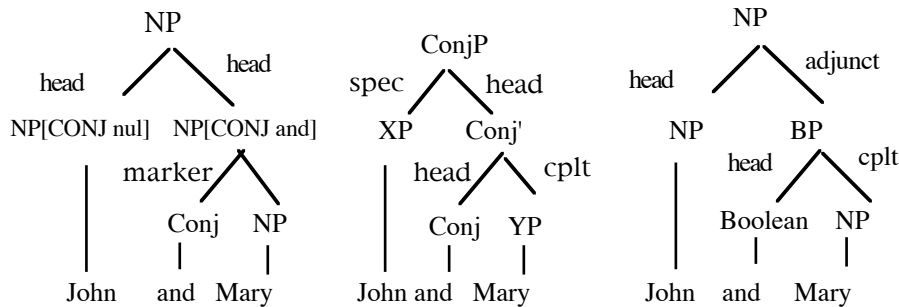

Starting with symmetric analyses, Sag et al (1985) have proposed, within GPSG, that all conjuncts be heads. This provides a straightforward account for syntactic feature sharing between the conjuncts (and ATB extraction), as well as an analysis of unlike coordination such as (4a) since Head features are intersected and the resulting phrase can be underspecified:

- (4) a John is a Republican and proud of it  
 b What did John run to the store and buy ?

But it makes it difficult to account for asymmetric conjuncts, as in (4b). For violations of ATB constraints, Sag et al posit a special rule coordinating V and VP in English, and other asymmetries (such as inflection or case marking on only one conjunct) would require more schemata. So this approach is only well suited for symmetric coordination (where the conjuncts can be unlike but the order between them can be reversed).

Adopting the opposite view, Pollard and Sag (1994), Sag and Wasow (1999) have assumed that coordinate phrases are the only non-headed types of phrases. This is meant to capture the fact that some features (eg number for NPs) are specific to the coordinate phrase, but for all other features this leads to adding sharing constraints between the phrase and the conjuncts, as well as between the conjuncts. On the other hand, if one views the Generalized Head feature principle as imposing default unification of Synsem values (as in Ginzburg et Sag 2000), one could benefit from default unification for distributive features (such as MOD, COMPS or PRED), and add specific values (associated with a coordinate type of phrase) only when needed.

Let us now turn to asymmetric approaches, that identify only one conjunct as the head. Reductionist approaches (Kayne 1994, Johannessen 1998) reduce

coordinate structures to X-bar schemata, with the Conjunction as the head, the first Conjunct as the Specifier and the second one as the Complement (cf also Paritong 1992 for an HPSG version). As pointed out by Borsley (1994), (2002), this type of analysis faces several syntactic problems : first, it is not expected that a phrase behaves like its specifier (=NP, PP etc). Second, if the marked conjunct is the syntactic head of the whole coordinated phrase, it should appear last in strictly head-final languages such as Japanese or Korean, contrary to fact (5a,b).

- (5) a    hon-to pen                    (Japanese)  
       b    book-and pen  
       b    Sunwoo-wa Hiyon        (Korean)  
           Sunwoo-and Hiyon

Third, it does not extend to n-ary coordinations : if the unmarked conjunct is analysed as a specifier, one expects only one specifier per phrase. If one alternatively tries to analyse ternary coordinations as embedded binary coordinations (with an empty first conjunction), one does not see how to prevent them from being introduced by *both*, *either* etc (cf Borsley 2002):

- (6) a    John, Bob and Mary  
       b    \* Both John, Bob and Mary

Munn (1992, 2000) has proposed that the conjunction heads a Boolean phrase that is adjoined to the other conjunct. This accounts for cross-linguistic word order variation (the unmarked conjunct is the head), but not for feature sharing between the conjuncts. It does not extend to n-ary coordinations, nor to coordinations with multiple conjunctions.

Our proposal is that both structures (1) and a revision of (3) are needed. Structure 1 accounts for n-ary coordinations, and for coordinations with multiple conjunctions. Structure 3 accounts for asymmetric coordinations such as Russian comitative coordination, where the case of the NP is that of the first conjunct (cf Mac Nally 1994):

- (7) a    Anna s        Petej pridut  
       b    Anna-nom with Peter-instr are-coming-plur  
       b    \* Petej s Anna pridut

If some "conjuncts" as in (7a) are to be analysed as adjuncts, the only revision needed with structure (3) is that the category of the adjunct should vary with

its complement (NP, PP...). We first provide more cases of such "adjoined" conjuncts, before turning to our HPSG analysis.

## 2. Some conjuncts as adjuncts

We first present some French data, then turn to some cases of verbal coordinations in Welsh and Korean.

French coordination involves 4 basic coordinating conjunctions : *et* (and), *ou* (or), *mais* (but), *ni* (nor). We first consider *car* (since), which interestingly shares some properties with coordinating conjunctions and others with synonymous subordinators such as *puisque* (since) or *parce que* (because), and then turn to incidental coordinations introduced by the basic conjunctions.

### 2.1. French CAR

*Car* is used to introduce finite clauses, with a causal meaning:

- (8) Paul est parti *car* il pleuvait  
Paul has gone since it was raining

A traditional debate in French grammars is to determine whether *car* is a coordinating or a subordinating conjunction. We think it is necessary to distinguish the lexical properties of *car* from the syntactic properties of the phrase it introduces.

First, *car* shares some properties with coordinating conjunctions. Like other conjuncts, *car* phrases cannot be conjoined, while subordinate clauses introduced by a preposition or a complementizer can:

- (9) a Jean est parti *parce qu'il pleuvait et parce que Marie était là.*  
Jean has gone because it was raining and because Marie was there  
b \* Jean est parti *car il pleuvait et car Marie était là.*  
Jean has gone since it was raining and since Marie was there

Unlike subordinating conjunctions, *car* cannot be replaced by *que* in the second conjunct, when one coordinates two S's under *car*:

- (10) a Paul n'est pas venu *car il pleuvait et il faisait froid.*  
Paul didn't come since it was raining and it was cold  
b \* Paul n'est pas venu *car il pleuvait et qu'il faisait froid.*  
c Paul n'est pas venu *puisque il pleuvait et qu' il faisait froid.*  
d Paul n'est pas venu *comme il pleuvait et qu'il faisait froid.*

*Car* cannot occur initially, differently from synonymous complementizers (*puisque S*):

- (11) a \* *Car* il pleuvait, Paul n'est pas sorti.  
Since it was raining Paul has not gone out  
b *Puisqu'il* pleuvait, Paul n'est pas sorti.

The *car S* can behave as a main clause : clitic subject inversion is possible (cf Wilmet 1997):

- (12) a Paul est parti *car* avait-il le choix ?  
Paul has gone since did he have the choice ?  
b Paul est parti *car* peut-être voulait-il voir Marie.  
Paul has gone since maybe did he want to see Marie

So the *car S* is not necessarily a subordinate clause, but is it a coordinate clause ? Like other clauses introduced by *puisque* or *bien que*, the *car* phrase must be an S or a predicative phrase (which can be analysed as a reduced clause):

- (13) a Jean est fonctionnaire [*car/ puisque* professeur]NP  
Jean is civil servant since teacher  
b Jean est heureux [*car* bien portant]AP  
Jean is happy since healthy  
c Jean est heureux [*bien que* malade]AP  
Jean is happy although sick

Unlike coordinate phrases, *car* phrases cannot be non finite VPs nor lexical conjuncts:

- (14) a \*Jean veut venir *car/ puisque* voir Marie  
Jean wants to come since see Marie  
b Jean veut venir et /ou voir Marie.  
Jean wants to come and/or see Marie  
c Jean lit [*et / \*car* traduit]V Proust  
Jean reads and/since translates Proust  
d \*Les soldats [*car / puisque* officiers]N  
The soldiers since officers  
e Les soldats et officiers.  
The soldiers and officers

A shared subject cannot be omitted in *car* phrases, unlike what we find in coordinate clauses :

- (15) a Jean est venu et (il) a vu Marie.  
Jean has come and (he) has seen Marie

- b Jean est venu car \*(il) a vu Marie.
- c Jean est venu parce qu' \*(il) a vu Marie.  
Jean has come since he has seen Marie

In (15b), like in the adjunct clause (15c), the subject 'il' cannot be omitted, while it can in a coordinate clause like (15a). The same contrast holds for gapping, and the *car* clause does not behave like a coordinate clause:

- (16) a Jean vend des chaises et Marie des tables  
Jean sells chairs and Marie tables
- b Jean vend des chaises car Marie \*(vend) des tables.  
Jean sells chairs since Marie sells tables
- c Jean vend des chaises puisque Marie \*(vend) des tables.

Crucially, the *car* phrase does not obey the Coordinate Structure Constraint : one can extract out of the main clause, without extracting out of the *car* clause (17a). Moreover, no parasitic gap is allowed in the *car* clause (parasitic gaps are disallowed in finite adjunct clauses in French):

- (17) a le parapluie que j'ai pris car il pleuvait  
the umbrella that I took  $\emptyset$  since it was raining
- b \*le parapluie que j'ai pris car Paul m'avait offert  
the umbrella that I took  $\emptyset$  since Paul offered me  $\emptyset$
- c \* le parapluie que j'ai pris parce que Paul m'avait offert

Our conclusion is that *car* is a coordinating conjunction (CC), which explains why it cannot be preceded by another CC, and why the *car* phrase cannot be initial. But instead of introducing a coordinate phrase, it introduces an adjunct phrase, which explains why it is an island for extraction. This adjunct phrase is not a subordinate clause (it does not trigger *que* coordination, it allows clitic inversion).

Turning now to incidental coordinations, we show that this apparently idiosyncratic behaviour of *car* is not exceptional, and that all coordinating conjunctions can introduce adjunct phrases in French.

## 2.2. Incidental coordinations

Incidental coordinations (i.e. coordinations with an incidental prosody) are of the form: *S Conj XP*.

- (18) John read the book (and) avidly.

Progovac 1998 has provided an analysis in terms of unlike coordination between VP and XP (with a possibly empty conjunction). This analysis does

not predict that the order of "conjuncts" cannot be reversed, nor that extraction is allowed out of the first "conjunct" :

- (19) a \* John avidly and read the book.  
b The book that John read, and avidly.

Focussing on French, Marandin (1998) has shown that such *Conj XPs* have a special intonation, and the same mobility as incidental adverbs (except S initial position):

- (20) a Jean, et c'est heureux, a lu votre livre  
Jean, and it is fortunate, has read your book  
b Jean a, et c'est heureux, lu votre livre  
c Jean a lu, et c'est heureux, votre livre  
d Jean a lu votre livre, et c'est heureux

- (21) a Jean a, mais trop tard, lu votre livre  
Jean has , but too late, has read your book  
b Jean a lu, mais trop tard, votre livre  
c Jean a lu votre livre, mais trop tard

- (22) a Jean, ou bien Marie, lira votre livre  
Jean, or else Marie, will read your book  
b Jean lira, ou bien Marie, votre livre  
c Jean lira votre livre, ou bien Marie

- (23) a Heureusement, Paul a lu votre livre  
Fortunately, Jean has read your book  
b \* Et c'est heureux, Jean a lu votre livre  
c \* Ou je me trompe, Jean a lu votre livre  
d \* Mais trop tard, Jean a lu votre livre

We show that these constructions do not involve coordinations. Such incidental conjuncts can be of various categories: NPs, PPs, Ss... They cannot be analysed as extraposed from an NP or PP coordination. The agreement pattern is different from that of NP coordinations. In French, *ou* triggers singular or plural agreement, but when the 'ou NP' is incidental, only the singular is allowed (cf 22); *et* triggers plural agreement, but not with incidental *et NP*:

- (24) a Jean ou Marie lira / liront votre livre.  
Jean or Marie will-read-sg / plur your book  
b Jean lira /\* liront votre livre, et Marie aussi  
Jean will-read-sg your book, and Marie too.  
c Jean et Marie liront /\*lira votre livre.

An alternative analysis would be to analyse these constructions as S (or VP) coordinations, with the incidental conjunct being a reduced S (or VP). It is true that semantically the incidental conjunct is interpreted as a parenthetical clause. But a reduced S (or VP) analysis fails on syntactic grounds, because extraction can involve only the main clause and not the incidental conjunct:

- (25) a un livre que Jean a lu à ses enfants, et c'est heureux.  
 a book that Jean has read to his children, and it is fortunate  
 b un enfant dont le père viendra, ou bien Marie  
 a child of which the father will come, or else Marie

This violation of the CSC would be odd if the incidental conjunct was a coordinated S (or VP). The facts follow if it is analysed as an adjunct: like other adjuncts, it is mobile, and it is an island for extraction.<sup>2</sup>

Our conclusion is that incidental conjuncts are syntactic adjuncts. They can be of any (phrasal) category, provided that have the semantic type: proposition.<sup>3</sup>

Let us now turn to two other languages, which also have "conjuncts" syntactically behaving as adjuncts.

### 2.3 Welsh serial coordination

Welsh serial coordination is characterised by the following properties (cf Rouveret 1994, Sadler 2003): Tense is marked only on the first conjunct, the others involve "verbal nouns"; the order of the conjuncts is fixed (and usually indicative of narrative progression); the subject is shared between the conjuncts (examples from Rouveret):

- (26) a Aethant i'r ty ac eistedd a bwyta  
 go-past-pl to the house and sit-VN and eat-VN  
 They went to the house and sat and ate  
 b Aeth y ffermwr at y drws a churo arno  
 Go-past-sg the farmer to the door and knock-VN on-it  
 The farmer went to the door and knocked on it

Rouveret analyses such cases as asymmetric TP coordination: the tensed V moves to Agr, the untensed VP adjoins to the first VP (which has an empty

<sup>2</sup> Only parasitic gaps are allowed as in:

(i) un livre dont l'auteur viendra, ou l'éditeur  
 a book of-which the author will-come, or the publisher

<sup>3</sup> The same facts hold for English, assuming 'but John' is incidental:

a Noone but John was /\*were here.  
 b A man that no friends of, but John, will admire  
 c \*A man that John, but no friends of, will admire

Tense but a full subject). Sadler 2003, working in LFG, proposes an analysis in terms of unlike coordination with a flat structure :

IP -> IP (Conj VP)<sup>+</sup>  
 □ □ ↑ □ = ↑ □ □ ↑  
 □ tense = ↑tense  
 □SUBJ = ↑SUBJ

Tense and Subject of the first conjunct are shared with the other conjuncts at f-structure. Such an analysis, based on unlike coordination, has to stipulate that the order of conjuncts cannot be reversed. It also has to stipulate that the conjunction has to be repeated on each untensed VP (whereas ternary coordination usually allow sequences with only the last conjunct marked). Without going into the details of the construction, we follow Rouveret in that such constructions do not involve coordination. We propose that the untensed conjunct is adjoined to the first clause, which we analyse as the head. An important argument (given by Sadler 2003) is that such constructions do not obey the CSC : one can extract out of the tensed conjunct without extracting out of the other conjuncts:

(27) I'r ty yr aethant ac eistedd a bwyta  
 to the house PT go-past-pl and sit-VN and eat-VN  
 It's to the house that they went and sat and ate

Another argument is that, since Welsh is a head initial language, we predict that the untensed VP must follow the tensed one which is the head. We also analyse apparent ternary examples like (26a) as iterated adjunctions: it follows that the conjunction has to be repeated on each untensed conjunct. Since *ac* is also used for plain symmetric coordinations, we take Welsh serial "coordination" as another argument that "coordinating" conjunctions can introduce adjuncts.

#### 2.4 Korean VP coordinations

S or VP coordination in Korean uses the suffix *-ko* on the first conjunct. Such coordinations can be symmetric, as in (28a) or asymmetric as in (28b) where the first conjunct is untensed (cf Choi 1999, Kim 2000):

(28) a Kim-un wain-ul masi-ess-ko Lee-ka maykcwu-lul masi-ess-ta  
 Kim-top wine-acc drink-past-conj Lee-nom beer-acc drink-past-decl  
 Kim drank wine and Lee drank beer  
 b Kim-un wain-ul masi-ko Lee-ka maykcwu-lul masi-ess-ta  
 Kim-top wine-acc drink-∅-conj Lee-nom beer-acc drink-past-decl

As shown by Choi 1999, the meaning is slightly different : in (28a) we have two different events, in (28b) there is a particular relationship (causal or temporal) between the two events that make up one event.

Tense marking cannot be considered as optional in the first conjunct. As shown by Kim (2000), the syntactic properties are different. The first conjunct is mobile when it is untensed, and not when it is tensed. In (29a) the untensed conjunct occurs between the subject and the object, while in (29b) the first tensed conjunct cannot:

- (29) a Kim-un [Lee-ka ttena-ko] ungun g wulessta  
 Kim-top Lee-nom leave-conj eyes-out cry-past-decl  
 Kim cried his eyes out since/because Lee left  
 b \* Kim-un [Lee-ka ttenass-ko] ungun g wulessta  
 Kim-top Lee-nom leave-past-conj eyes-out cry-past-decl

Crucially, coordination of two tensed clauses obey the Coordinate Structure Constraint, while coordination with an untensed clause does not. In (30a), one can extract out of the tensed clause, without extracting out of the untensed clause (examples from Kim 2000):

- (30) a Mwues-ul John-i [pap-ul mek-ko] thakcawi-ey noh-ass-ni ?  
 what-acc John-nom meal-acc eat-conj table-loc put-past-quest  
 What did John put on the table and eat the meal ?  
 b \* Mwues-ul John-i [pap-ul mek-ess-ko] thakcawi-ey noh-ass-ni ?  
 what-acc John-nom meal-acc eat-past-conj table-loc put-past-quest

Kim's conclusion, which we share, is that the untensed conjunct is an adjunct clause. As Korean is a head final language, it is predicted that it must precede the tensed main Verb. So a ko-marked clause can behave as a coordinate phrase or as an adjunct phrase.

### 3. Representation within HPSG

We now show how the two sides of our analysis can be represented within HPSG:

- the conjunction forms a subconstituent with one of the conjuncts (first or last depending on the language),
- such a constituent can have several functions (coordinate daughter or adjunct daughter).

#### 3.1. The conjunction as a weak head

Since the conjunction tends to follow its conjunct in head-final languages and to precede it in head-initial languages, it can be a marker (as in Sag et al 1985) or a head. Recent HPSG research tends to reanalyse most markers as



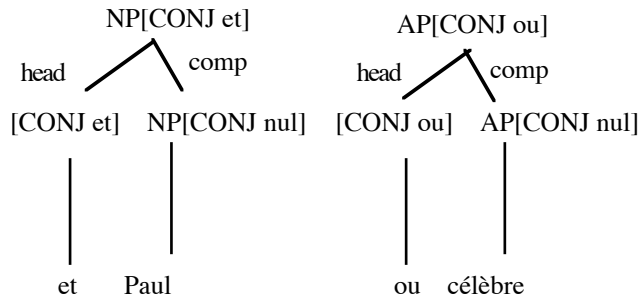

The type *canonical* on the complement of the conjunction prevents extraction such as the following:

(32) \* What did you see a picture of and ?

As in Gazdar et al 1985, we use a CONJ feature which distinguishes the complement from the conjunct phrase, and prevents the conjunct phrase from being an argument. We posit a general constraint on words:<sup>6</sup>

(33) word => ARG-ST list([CONJ nil])

Notice that this prevents the conjunct phrase from being the complement of another conjunction. The ban on stacking conjunctions (*\*et ou* , *\*mais et* ...) is thus provided at no cost.

The conjunct phrase cannot be subject nor complement, but can have several functions :

- coordinate daughter: Jean et Marie (Jean and Marie)
- adjunct daughter: Jean viendra, ou Marie (Jean will come, or Mary)
- main clause Et il est parti ! (And he's gone)

### 3.2. Coordinate phrases

For coordinate constructions, we define coordinate phrases as multi-headed, with at least one CONJ marked daughter (nelist means 'non empty list'):

coord-phr => [CONJ nil] [HD-DTRS nelist([CONJ nil]) nelist([CONJ nil])]

We rely on a Precedence rule that orders marked conjuncts last:

<sup>6</sup> (33) is not necessarily a universal constraint. In Slavic languages, such as Russian or Czech, the AND conjunction (i) can mark a subject or a complement and is interpreted as a focus marker (=even).



(37) Hierarchies for features PER and GEN:

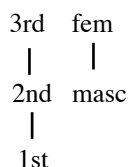

For French, different subtypes of coordinated phrases are needed, based on headedness (NP or not) and on arity (depending on the conjunction).<sup>7</sup> We distinguish binary phrases (with the conjunctions *mais* or *ni*), and n-ary phrases (with *et* or *ou*):

(38) bi-coord-phrase => DTRS <[CONJ nil], [CONJ mais/ ni]>  
n-ary-coord-phrase => DTRS <...[CONJ et/ou]>

We thus exclude examples such as the following:

- (39) a ?? Jean est riche, célèbre mais malheureux.  
Jean is rich, famous, but unhappy  
b \* Jean est riche, mais célèbre mais malheureux.

### 3.3. Representation of French *car*

As shown above, we say that *car* is a conjunction (with a [CONJ *car*] feature), takes a (main) S (indicative) or [PRED +] complement, which is an island for extraction (SLASH {}), and has a [MOD V] feature (that forces the *car* phrase to be used as an adjunct). The lexical entry for *car* is thus as follows:

(40) Lexical entry for *car*:

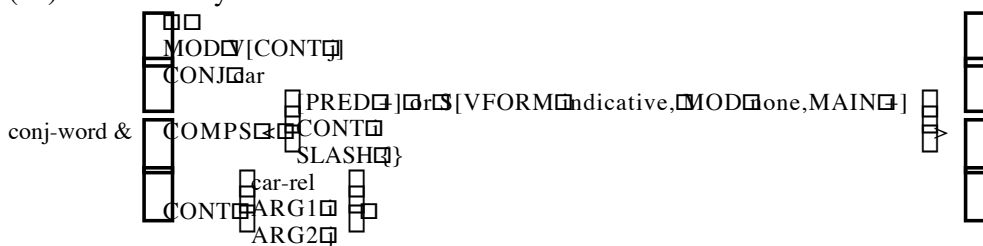

We use the standard head-adjunct phrase, and the same LP rule as for coordinate phrases (a CONJ marked phrase must be final):

<sup>7</sup> More subtypes may be needed in order to account for the specificities of lexical coordinations, as well as coordination with multiple conjunctions.

(41) hd-adj-phrase => [CONJ nil] < [CONJ ≠nil]

Notice that *car* clauses cannot be coordinate daughters because their MOD feature would conflict with that of the first conjunct (assuming finite Ss are [MOD none]).

### 3.4. Incidental conjuncts

We represent incidentals as adjuncts with a boolean Head INCIDENT feature, as in Bonami and Godard 2003. We analyse incidental conjuncts as V adjuncts, which enter into Head-adjunct-phrases or Head-complements-adjuncts-phrases:

(42) Head-Comps-Adj Phrase:

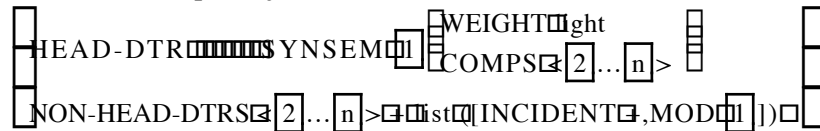

Ordering of incidental adjuncts is free in the hd-comp-adj-phrase and constrained by (41) in the hd-adj-phrase.<sup>8</sup>

For incidental conjunct phrases, we define a subtype of conjunction word, with the appropriate features. We thus have two subtypes of conj-words : basic-conj-word and discourse-conj-word.

Basic-conj-word are marked as [INCIDENT -] and share (by default) the INCIDENT value of their complement. They also inherit the MOD value of their complement.<sup>9</sup> Discourse-conj-word have a specific [MOD V] feature, which they do not necessarily share with their complement, and an [INCIDENT +] feature, which their complement does not have. Semantically, discourse conjunctions are binary relations and take the phrase they modify as one of their arguments. They force their complement to be interpreted as a proposition.

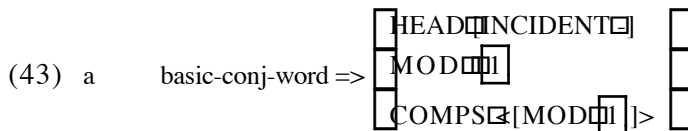

<sup>8</sup> Bonami and Godard deal with incidental adverbs, using a specific binary incidental-adjunct-phrase and domain union for linearization.

<sup>9</sup> As in Sag and Wasow 1999, we consider MOD as a VAL feature, and not a HEAD feature.

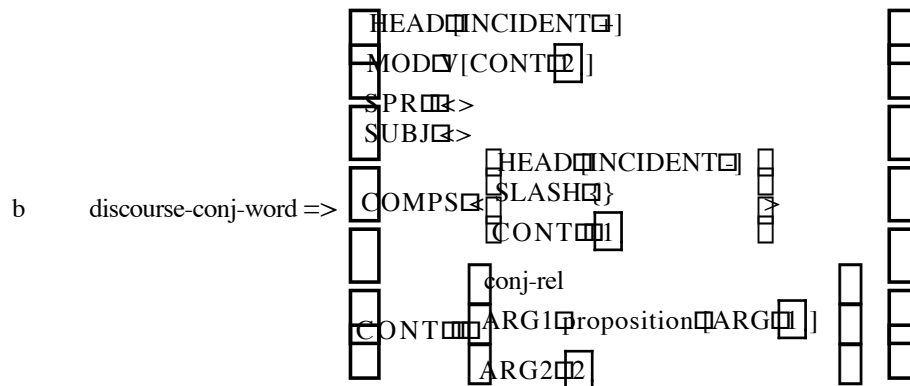

For incidental conjuncts, we thus have representations like the following:

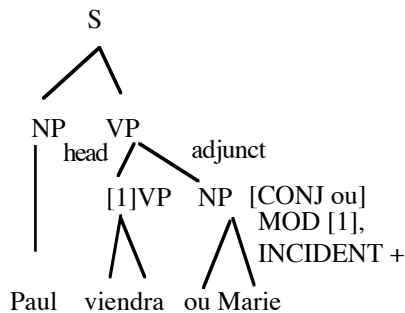

Interestingly, the same lexical entries can be used for conjuncts as main clauses (or discourse conjuncts), to which we now turn.

### 3.5. Conjuncts as main clauses

Main clause conjuncts can be either full clauses or fragments:

- (44) a Mais Paul est parti! But Paul is gone !  
 b Et Paul ? And Paul ?

They can denote questions, propositions or exclamations ("messages" in Ginzburg and Sag 2000). We analyse such conjuncts as clauses inheriting from the head-only phrase. They involve the same lexical entry for conjunctions as incidental conjuncts. The conjunction takes two semantic arguments: its complement (interpreted as a proposition), and another clause available in the discourse context. So we identify the denotation of the MOD value of the conjunct phrase with that of the Context. We thus have the following (simplified) subtype of construction :

(45) Unary-conj-phr =>

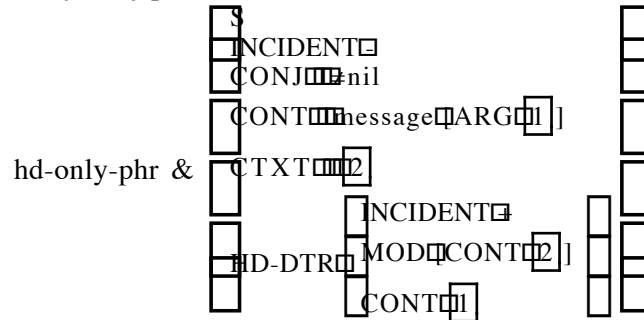

Message is the denotation of a clause (= proposition, question, fact .. cf Ginzburg & Sag 2000) and the second semantic argument of the conjunction is provided by the Context. The [CONJ] feature of the conjunction is passed from the Head Daughter to the Mother, and prevents such clauses from being used as subcategorized arguments.

A (simplified) classification of constructions involving a conjunct phrase in French is thus the following:

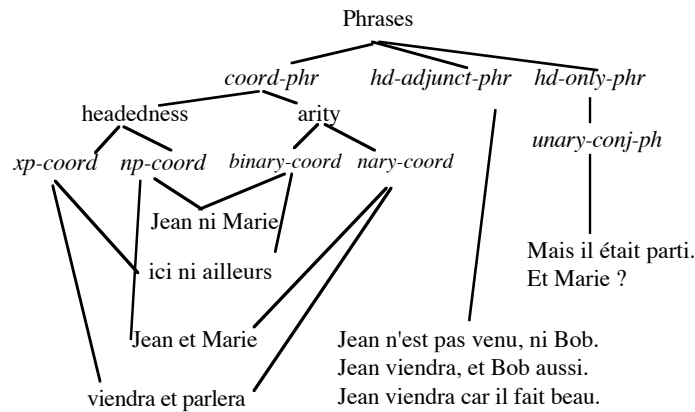

## Conclusion

On the basis of data from French, Welsh and Korean, we have proposed to:

- distinguish Conjunction as a type of word and Coordination as a type of construction,
  - analyse Conjunctions as weak syntactic heads, yielding a Conjunct phrase
  - analyse incidental conjuncts and some asymmetric conjuncts as adjuncts.
- We have shown how Conjunct phrases can enter into several constructions (head-only-phrases, head-adjunct-phrases and coord-phrases).

### References

- A. Abeillé, O Bonami, D Godard, J Tseng 2003, The syntax of French *à* and *de*, ACL-SIGSEM Workshop on Prepositions, Toulouse
- O. Bonami, D Godard, 2003. Incidental adverbs : an overlooked type of adjunction, HPSG Conference, East Lansing, Michigan.
- R. Borsley 1994. In defense of coordinate structures, *Linguistic Analysis*, 24-3-4, 218-246.
- R. Borsley 2002. Against ConjP, *Lingua*.
- H-W. Choi 1999. *Optimizing structure in context*, Stanford: CSLI Publications.
- M. Dalrymple, R. Kaplan 2000. Feature indeterminacy and feature resolution, *Language*, 76(4), 759-798.
- G. Gazdar, E. Klein, G. Pullum, I. Sag 1985. *Generalized Phrase structure Grammar*, Oxford, Basil Blackwell.
- J Ginzburg, I Sag 2000. *Interrogative investigations: the form, meaning and use of English interrogatives*, Stanford: CSLI Publications.
- R. Huddleston, G. Pullum 2002. *The Cambridge grammar of English*, Cambridge: Cambridge University Press.
- J-B. Johannessen 1998. *Coordination*, Oxford: Oxford U. Press.
- R. Kayne 1994. *The antisymmetry of syntax*, Cambridge: MIT Press.
- J-B. Kim 2000 *The grammar of negation, A constraint based approach*, Stanford: CSLI Publications.
- R Levy, C Pollard, 2001. Coordination and neutralization in HPSG, HPSG Conference, CSLI Publications.
- L. MacNally 1994. Comitative coordination: A case study in group formation, *Natural language and Linguistic Theory*. 11:347-379.
- J-M. Marandin 1998. Grammaire de l'incidence, ms, LLF, Université Paris 7.
- A. Munn 1992. A null operator analysis of ATB gaps, *Linguistic Review*, 9, 1-26.
- A. Munn 2000. Three types of coordination asymmetries, in K. Schwabe, N. Zhang (eds) *Ellipsis in Conjunction*, Tübingen: Max Niemeyer Verlag.1-22.
- M. Paritong 1992 Constituent coordination in HPSG, in G Görz (ed) *Konvens*, Springer verlag
- C. Pollard, I. Sag 1994. *Head-driven Phrase structure grammar*, Chicago Press.
- L. Progovac 1998. Avoid conjunction reduction, and coordination of likes constraint, *Formal approaches to Slavic linguistics*, Michigan Slavic Publications, 252-266.
- J. Ross 1967. Constraints on variable in syntax, MIT Phd Thesis.
- A. Rouveret 1994. *Syntaxe du gallois: Principes généraux et typologie*, Paris: CNRS Editions.

- L. Sadler 2003. Tense concord in coordination, Conference on Celtic Languages, King's college.
- I. Sag, G Gazdar, T Wasow, S Weisler 1985. Coordination and how to distinguish categories, *Natural Language and Linguistic Theory*, 3, 117-171.
- I. Sag 1997. English relative clause constructions, *Journal of linguistics*, 33: 431-484
- I. Sag, T Wasow 1999. *Syntactic theory : a formal introduction*, Stanford: CSLI Publications.
- I. Sag 2002. Coordination and underspecification, HPSG Conference, Seoul.
- J. Tseng 2001 Remarks on marking, HPSG Conference, Trondheim.
- M. Wilmet 1997. *Grammaire critique du français*, Paris:Hachette Université.