

More Head and Less Categories: A New Look at Noun Phrase Structure

John Beavers

Department of Linguistics

Stanford University

Stanford, CA, 94305

`jbeavers@csl.i.stanford.edu`

Proceedings of the HPSG03 Conference

Michigan State University, East Lansing

Stefan Müller (Editor)

2003

CSLI Publications

<http://csl-i-publications.stanford.edu/>

Abstract

Much literature in syntax has assumed that all noun phrases are categorically headed by the determiner or the noun, with well-formedness categorial in nature. In this paper I develop a theory of noun phrase structure in which both categories project noun phrases, arguing that this better fits the indeterminacy of the criteria often cited for determining headedness (Zwicky, 1985, *inter alia*). The only categorial differences between determiners and nouns are their semantics and selectional restrictions, and the conditions that determine well-formedness are semantic in nature. Specifically, a well-formed noun phrase must have some restrictive semantics associated with nouns coupled with some operational semantics associated with determiners (e.g. as a generalized quantifier), and from this I show how we can derive structural well-formedness. Thus the need for categorial well-formedness is nullified, providing an analysis with greater cross-linguistic import, being compatible with languages without determiners.

1 Introduction

Most theories of noun phrase structure (Harris, 1946, Jackendoff, 1977, Abney, 1987, Nerbonne et al., 1989, Payne, 1993, Pollard and Sag, 1994) have assumed that either the determiner (D) or the noun (N) is universally the syntactic head of the noun phrase (i.e. the element that categorially characterizes the phrase and determines its internal structure), and that a syntactically well-formed noun phrase is a fully saturated DP or NP, depending on the theory.¹ I will refer to such theories as theories of strict headedness. Much of the debate on noun phrase structure has been centered around whether it's the D or the N that is the head.

However, in this paper I argue that a careful examination of the data concerning headedness (cf. Zwicky (1985), Hudson (1987), Croft (1993), Zwicky (1993)) and noun phrase semantics does not support a strict headedness view. By examining a variety of old and new data, I will propose a semantically grounded alternative to strict headedness in noun phrases, characterized in (1):

- (1) (i) D and N are both *nominal* categories projecting nominal phrases (NomPs) and differ only in terms of semantics and selectional restrictions.
- (ii) A well-formed noun phrase is one that has both D and N-Semantics.

In other words, I propose that both Ds and Ns project noun phrases, with well-formedness dependent only on whether or not they are semantically complete. For any given noun phrase I maintain that there is indeed a unique head, and in particular for canonical noun phrases with both a D and an N I argue that the D selects for the N and heads the phrase, but in general it is possible for DPs or NPs to be well-formed noun phrases, conditioned only on semantic factors.

¹A note on terminology: I will use XP to stand for a phrase headed by category X, so a DP is a phrase headed by a D, and NP a phrase headed by an N. I will use "noun phrase" spelled out to refer to the pretheoretical notion of a noun phrase.

I discuss the data pertaining to headedness in section §2, concluding that no evidence isolates D or N as the head of the noun phrase. I turn to semantics in §3, arguing that there are semantic well-formedness constraints on noun phrase structure, and I look at the subcategorization properties of Ds and Ns in §4. In §5 I sketch a semantically driven analysis of bare plurals and noun phrase ellipsis, two instances of noun phrases that appear to be lacking either a D or an N. In §6 I sketch a way of removing any vestiges of syntactic well-formedness in noun phrase structure by moving to an underspecified semantic representation, with desirable cross-linguistic results. I'll compare this approach to alternative approaches in §7 and conclude in §8.²

2 Headedness

Turning first to the linguistic criteria that have been used to motivate headedness arguments, one of the first comprehensive surveys of what the valid criteria are is Zwicky (1985), although there has been much debate since on which of Zwicky's criteria are valid (see Hudson (1987), Croft (1993), Zwicky (1993)). Much of the debate, however, has been centered around the apparent indeterminacy of Zwicky's criteria, since they rarely isolate unequivocal heads for any construction, including noun phrases. However, I argue that the indeterminacy should instead lead us to a different conclusion, namely that there is no universal, single head for all noun phrases. I'll first go over the most common headedness criteria as applied to noun phrases and show that no conclusions can indeed be drawn.

The first criterion I'll examine is really a cluster of properties, usually characterized in terms of **obligatoriness**, wherein the head is the only obligatory element in a phrase. Variations of this criterion include **distributional equivalence**, wherein the head by itself has the same distribution as the full XP, and **category determination**, where the head is the thing that determines the category of the phrase. For example in the VP *eat (a sandwich)*, *a sandwich* is not obligatory and not distributionally equivalent to the full VP, but *eat* is obligatory, thus *eat* is likely the head. If we examine the data on noun phrases, however, neither D nor N appears to be obligatory or solely distributionally equivalent to the noun phrase:

- (2) (a) English: *Some dogs/dogs/some*
- (b) German: *(die) (alten) (Männer)* 'the old men'
- (c) Spanish: *(los) (gatos) (viejos)* 'the old cats'
- (d) Quechua:
 alkalde-kuna-ta mayor-PL-ACC 'the mayor [object]'
 hatun-kuna-ta big-PL-ACC 'the big ones [object]' (Croft, 1993)

In the English data in (2a) the full noun phrase *some dogs*, the N *dogs*, and the D *some* are all well-formed noun phrases, with roughly the same interpretation

²This sketch is based partly on a larger proposal in ? that also incorporates pronouns, proper names, possessors, possessive ellipsis, and *one*-anaphora. For purposes of this section I'll focus exclusively on D and N, ignoring most of these additional phenomena, although I'll make occasional reference to data beyond these two categories.

(taking into account of course ellipsis and generic/indefinite interpretation of bare plurals). Likewise for German and Spanish, any of D, N, and Adj can (by itself) constitute a valid noun phrase, and in Quechua N or Adj can. Therefore it doesn't appear obvious that any one element is, superficially, obligatory in the noun phrase.

The second criterion often cited for headedness is **subcategorization**, in the sense that the head is the item that subcategorizes for the non-head (where "subcategorize" means "requires the presence of" and not any particular theory of subcategorization). Here again we see the same indeterminacy:

- (3) (a) N subcategorizing for D:
**(The/this/that/a) picture of Mary is in black and white.*
- (b) D subcategorizing for N:
*A/the/every *(dog) slept soundly.*

In (3a), certain Ns (bare singular Ns) in some contexts require the presence of a D for well-formedness (barring potential "Universal Grinder" readings that occur in other contexts). Likewise, in (3b), some Ds (the articles *a/an* and *the* and the determiner *every*) categorically require the presence of an overt N. So it doesn't appear to universally be the case that D or N is necessarily subcategorizing for the other, thus furthering the indeterminacy of headedness. Turning next to morphology, it has been argued (in particular by Zwicky (1985), but see also Hudson (1987)) that the head is the element of the phrase that is the **locus of morphosyntactic marking**, e.g. inflection. Here again, however, we see that this criterion does not isolate a single head, since D and N share category features:

- (4) (a) D/N show person/number morphology:
John saw some dogs/a dog.
- (b) D/N show case:
 German:
den Mann the-ACC man "the man [object]"
der Mann the-NOM man "the man [subject]"
des Mannes the-GEN man-GEN "the man's"
- Russian:
temi poslednimi bol'šimi butylkami
 that.INST.PL last.INST.PL big.INST.PL bottle.INST.PL
 'with those last big bottles'
- (c) (Pronominal) Ds show case in English:
*We/*us linguists need more sleep.*

In (4a), we see that in English both D and N show person and number morphology (third person singular/plural in this example, see also the Quechua data in (2)). In (4b,c), we see that D and N (and Adj in Russian and in Quechua above) show case marking, even in English (on the assumption that pronouns in such uses

as (4c) are pronominal determiners). Thus it does not appear that of D, N, and even Adj any element is unequivocally the morphosyntactic locus of the phrase and thus its head. Finally, Croft (1993) in particular argues that the only true criteria for headedness is semantics, wherein the head is the element that is the most **semantically characteristic** of the whole phrase. For example, *eating a sandwich* is a kind of *eating* but not a kind of *sandwich*, so therefore *eating* is the head. This is a very difficult criterion to apply to noun phrases due to the semantic infelicity of such tests. For instance, it makes about as much sense to say that *every dog* is a kind of *dog* as it does to say that *every dog* is a kind of *every*, although this may be a purely trivial meta-linguistic fact. However, given that the interpretation of a noun phrase like *every dog* (as a set, a referential entity, a generalized quantifier, etc.) is not necessarily a cut and dry issue it's not clear that this test would be fruitful however formulated. Therefore on semantic grounds it's not entirely clear that either the D or the N is the head of the noun phrase.

Despite the indeterminacy, most people have concluded that the D or the N is the head anyway. Zwicky (1985) for instance concludes that the head most closely corresponds to the morphosyntactic locus, which he regards as the N, claiming the rest of the criteria are independent. Hudson (1987), on the contrary, argues that the D is the head by reevaluating most of Zwicky's criteria in terms of semantic functorhood, wherein he regards the D as the semantic functor in a noun phrase and argues that the retooled criteria concur with this notion. Croft (1993) assumes third the possibility that none of the criteria are any good, although he ultimately takes a semantically based view of headedness related to semantic "aboutness". I instead assume the fourth possibility, which, with no additional assumptions, is the most parsimonious: since D and N project phrases that are interchangeable (cf. (2)), place constraints on each other's distributions (cf. (3)), and have the same morphosyntactic category features (cf. (4)), then they are the same category and thus *both D and N project noun phrases*.³

This generalization can be encoded quite straightforwardly into the part-of-speech type hierarchy of an HPSG grammar (based on Ginzburg and Sag (2000)):

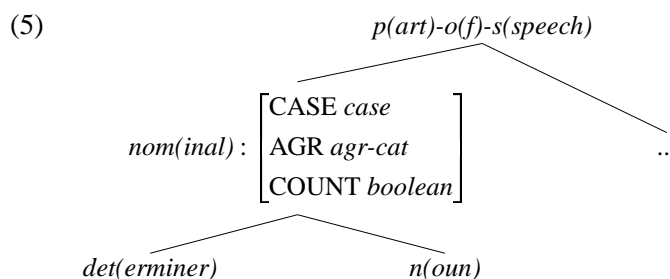

The type *nominal* I will assume has the relevant category features of both D

³See Postal (1966) for a similar argument about D and Pro; Hudson (2000) assumes that Ds are just transitive Pros, which means that if Pro and N are related categories then so are D and N.

and N, and that D and N are its subtypes (represented by *det* and *n*).⁴ I will furthermore assume that what verbs are selecting for are not NPs or DPs but simply NomPs, something headed by either element. Before encoding this formally, I will discuss what differences do exist between D and N, namely semantics and subcategorization, in the following sections.

3 Semantics

Despite the categorial relatedness of Ds and Ns, there are of course clear semantic differences between them, namely that Ns are associated with thematic information and Ds with some sort of operative semantics, informally outlined in (6):

- (6) (a) D-Semantics: quantification, definiteness, genericity, etc.
 (b) N-Semantics: attributive/restrictive semantics, the restriction set (*dog'*, *cat'*, *fish'*, etc.) of some kind of quasi-quantificational operator.

This is a largely uncontroversial observation (basically it's just saying that Ns are kind denoting and Ds contribute quantificational/referential properties (Szabolcsi, 1987, Longobardi, 1994, Chierchia, 1998), or that Ns denote restrictions and Ds denote set relations in a generalized quantifier (GQ), e.g. see Montague (1974), Barwise and Cooper (1981)).⁵ I encode this distinction into a semantic type hierarchy based on Ginzburg and Sag (2000) (with new types in boldface):

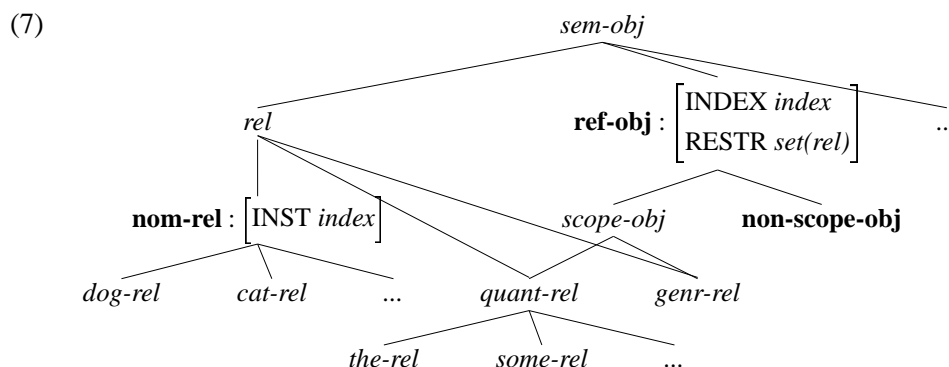

To Ginzburg and Sag's hierarchy I add a supertype *ref-obj* for all nominal semantics, a type *non-scope-obj* for nominal items (like nouns) that do not inherently contribute scopal semantics, and a type *nom-rel*, corresponding to N-semantics. Subtypes of this type include nominal predicates such as *dog-rel*. The type *scope-obj* corresponds to D-semantics. I propose the following lexical constraints linking these semantic types to the categories outlined above:

⁴Potentially, though I will not explore this option, separate categories for D and N may even be unnecessary once semantic and valence information is examined.

⁵Not all languages encode D-semantics via determiners, of course, using instead context, pragmatics, other morphosyntactic markers (like verbal prefixes in Mayan languages, aspectual markers in Russian, etc.). My claim is simply that when languages do have determiners they represent D-semantics. I'll return to cross-linguistic semantics in §6.

$$(8) \quad (a) \quad n\text{-}l\text{xm} : \left[\text{CONT} \left[\begin{array}{l} \text{non-scope-obj} \\ \text{INDEX } i \\ \text{RESTR} \left\{ \left[\begin{array}{l} \text{nom-rel} \\ \text{INST } i \end{array} \right] \right\} \end{array} \right] \right] \quad (b) \quad \text{det-lxm} : [\text{CONT } \text{scope-obj}]$$

Determiner lexemes have scopal semantics, whereas noun lexemes have non-scopal semantics but necessarily contain some *nom-rel* on their RESTR list predicating over their referential indices.⁶ With this hierarchy in place I now turn back to the linguistic data and note the following observation: all noun phrases have both D and N-semantics, as evidenced by (9).

- (9) (a) Noun phrase with both D and N:
 i. Every fish likes the movies.
- (b) Noun phrases with no N still have N-Semantics:
 i. Although most dogs eat dog food, many *e* prefer cat for dinner. (Ellipsis)
 ii. (These (books)/)they record who won the 1967 World Series. (Pronominal))
- (c) Noun phrases with no D still have D-Semantics:
 i. (Some) people know who won the 1967 World Series. (Generic)
 ii. I saw (some) dogs in the lawn. (Indefinite)
 iii. (Kim knows the answer. (Definite))

In (9a) it's clear that full noun phrases, with both D and N, have the semantic components contributed by both elements (e.g. *every fish* has the D-semantics contributed by *every* and the N-semantics contributed by *fish*). Likewise, noun phrases such as those in (9b) which do not have overt Ns still have interpretations involving N-semantics, either due to pronominal co-reference or through some process of ellipsis (e.g. *many* in (9b.i) has the same interpretation as *many books*, receiving N-semantics anaphorically through ellipsis). Finally, noun phrases lacking overt Ds as in (9c) still have D-semantic interpretations, either as generics, indefinites, or definites. Therefore, regardless of the presence or absence of either the D or the N, all noun phrases have semantic components of both types of elements. This is by no means a new insight, but it allows us to state the following well-formedness condition:

- (10) Nominal Phrase Semantic Well-formedness Condition (NPSWC): All well-formed noun phrases must have both D-semantics and N-semantics.

I'll encode this criterion (and the NomP criterion from the previous section) directly into the selectional restriction of elements taking nominal arguments:

⁶This is not necessarily the case for expletives, which I ignore here, although they could be straightforwardly modeled using default constraints (Lascarides and Copestake, 1999).

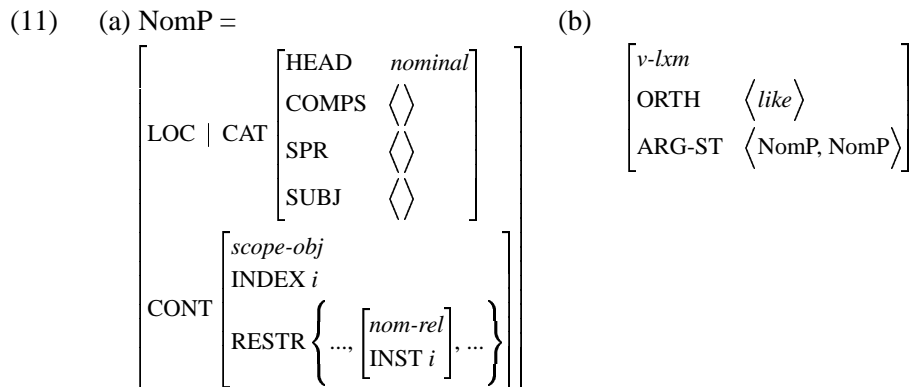

NomP is not a type; it is just an abbreviation for a feature structure representing a fully saturated noun phrase that has scopal (D-)semantics in which the referential index is predicated over by at least one nominal (N-)semantic element. Verbs like *like* take two NomP complements, rather than two NPs, thus encoding both the semantic and (lack of) categorial constraints motivated so far. In the next two sections, I'll examine the internal structure of various NomPs.

4 Subcategorization

Following Hudson (1984), Abney (1987), I'll assume that in general D subcategorizes for N (here meaning "selects for syntactically"), based not only on the type of evidence cited by much literature on DPs, but also additional, fresh data on Noun Phrase Ellipsis (NPE). I'll briefly recap the relevant data here. Abney assumes that D and INFL are parallel categories:

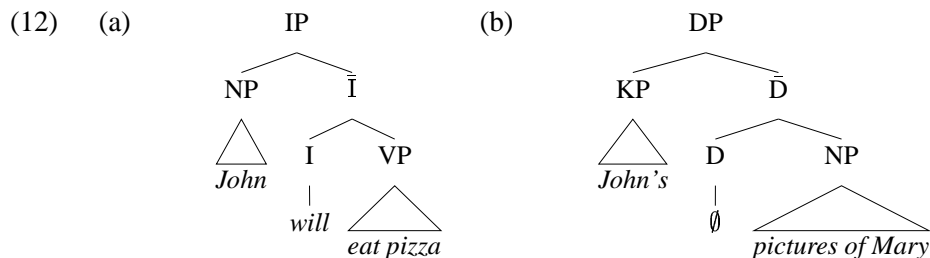

He supports this by showing that noun phrases and sentences are parallel projections, on the grounds that both have AGR (presumably a property of functional heads like INFL and, he argues, D) and related θ -grids. In terms of agreement and case features, there are striking cross-linguistic similarities between subjects of finite verbs and possessors. In many languages, such as Hungarian, Tzutujil, and Yup'ik, argument markings for subjects and possessors are identical:

- (13) (a) Hungarian:
- E'n nem akar-ok el-menni*
 I-NOM not want-1sg.indef away-go.inf
 "I don't want to go"

az en kalap-om
the I-NOM hat-1sg
“my hat”

(b) Yup’ik:

angute-m kiputa-a-∅
man-ERG buy-OM-SM
“the man bought it”

anguet-m kuiga-∅
man-ERG river-SM
“the man’s river”

(c) Tzutujil:

x-ix-qa-kunaaʃ
aspect-2pOM-1pSM-cure
“we cured you (pl.)”

qa-tzaʃn
1pSM-nose
“our nose”

(Abney, 1987)

In Hungarian possessors/subjects show nominative case, and in Yup’ik possessors and subjects of transitive verbs show ergative case. In Tzutujil there are no case markings, but the agreement morphology for verbs with their subjects and nouns for their possessors is identical, i.e. both are forms of subject agreement (separate morphology is used for agreement with objects). Looking more properly at agreement, many languages show the same morphology for subject/possessor agreement on both V and N, as in seen for Tzutujil in (13) and Yup’ik in (13) and also in (14):

- (14) (a) *kiputta-∅* “he bought it” *kuiga-∅* “his river”
(b) *kiputaa-t* “they (dual) bought it” *kuiga-t* “their (dual) river”
(c) *kiputaa-k* “they (plural) bought it” *kuiga-k* “their (plural) river”
(Abney, 1987)

In (14) the inflectional paradigm for number agreement of Ns with possessors and Vs with subjects is the same, further strengthening the similarities between the noun phrase and sentential domains. Finally, the preservation of θ -role assignments in nominalization (e.g. *The Romans destroyed the city/the Roman’s destruction of the city*) indicates further structural and semantic similarities between noun phrases and sentences. Assuming an S/noun phrase parallel, D and INFL fall naturally into

same structural position, thus motivating Abney's structures in (12). Turning back to HPSG, there is of course no INFL category nor an AGR in the same sense as in Government and Binding, but the most natural analogy of the S/noun phrase parallel would be to assume (building on the category supertype of D and N) an analogy to the way auxiliaries interact with verbs (following Pollard and Sag (1994)):

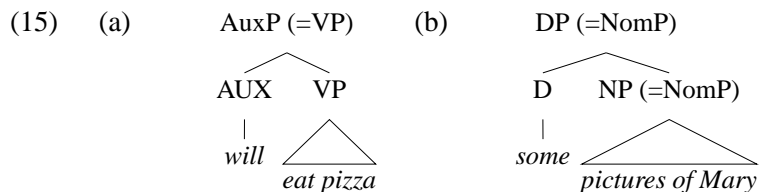

Just as Auxs are really Vs that take certain types of VP complements and project VPs, Ds are really Noms that take certain types of NomP complement (NPs) and project NomPs. In addition to Abney's data, there is also data on ellipsis that I think further supports the D/Aux parallel. Both D and Aux are capable of licensing ellipsis in highly parallel ways.⁷ Both Ds and Auxs license following NPs/VPs that may be overt, either non-anaphoric (regular NPs/VPs) or anaphoric (*one*-anaphora for Ds, *do so/it* anaphora for Aux), or else allow structures with covert NPs/VPs, either sense-anaphoric (ellipsis) or non-sense-anaphoric (for Ds, these are deictic or pronominal determiners that do not realize following NPs; for Auxs, these would be pragmatically controlled anaphora, which I'll turn to momentarily). This is summarized in (16).

(16)

		NPE		VPE	
		anaphor	non-anaphor	anaphor	non-anaphor
overt		<i>one</i>	NP	<i>so, it</i>	VP
covert		ellipsis	∅	ellipsis	∅

Examples of the four possibilities for both categories are outlined in (17).

(17)

		NP	VP
(a)	overt, anaphor (overt ellipsis):	<i>that one</i>	<i>did it/so</i>
(b)	covert, anaphor (ellipsis):	<i>some e</i>	<i>did e</i> (overt ant.)
(c)	overt, non-anaphor (full XP):	<i>some cat</i>	<i>did leave</i>
(d)	covert, non-anaphor (deixis):	<i>that e</i>	<i>did e</i> (pragmatic ant.)

Of the various kinds of ellipsis in English (gapping, sluicing, stripping, etc., cf. Ross (1967)), NPE/VPE are striking since they are the only two that allow overt elliptical elements. They also show striking distributional parallels. First, both allow pragmatic control, unlike gapping (Hankamer and Sag, 1976, Chao, 1988):

⁷I'll use NPE and VPE as cover terms for bare Auxs and Ds, although the interpretation is not always strictly speaking elliptical, as in the case of deixis.

- (18) (a) VPE: [In a context of two people eyeballing a freshly baked pie they know they're not supposed to taste yet] ?I will __ if you will __ .
 (b) NPE: [In the context of someone coming across a infestation of ants in her office] ?Look, some__ got into my computer!
 (c) Gapping: [In a context of someone witnessing a dog chase a cat] *A cat __ a sparrow. (=A cat chases a sparrow)

In these examples both NPE and VPE at least marginally allow antecedents that are not linguistically overt in prior discourse, so in other words are “deep anaphora”, in terms of Hankamer and Sag (1976), unlike gapping.⁸ Second, neither NPE nor VPE need to be in a command/sisterhood relationship with their antecedents, unlike gapping (cf. Jackendoff (1971), Chao (1988)).

- (19) (a) VPE: John doesn't enjoy movies but Bill does __ .
 (b) NPE: Each mathematician left behind his glasses but most __ came back and got them.
 (c) Gapping: John loves chocolates and Bill __ Cheerios.
 (d) Gapping: *John persuaded Fred that Bill __ Sam.

VPE and NPE both allow unbounded antecedents (or antecedents in different sentences), unlike gapping and most other types of ellipsis, showing further similarities between them.⁹ In addition to the evidence of Abney that S and noun phrase are parallel projections, the ellipsis data shows very clearly the similarities between D and Aux. Based on this evidence, we can assume, just as Aux selects for V, that D select for N and that N does not take a specifier:¹⁰

⁸The picture is not quite as nice as this. Hankamer and Sag (1976) did not classify VPE as deep anaphors, claiming that evidence such as (18a,b) are ungrammatical. But since then a variety of further data have come to light suggesting that VPE does indeed behave like deep anaphora, including allowing pragmatic control in some contexts (Hankamer, 1978, Chao, 1988). Admittedly, the evidence on pragmatic antecedents is not entirely robust, certainly not as robust as similar evidence for, say, *do so* anaphora. Probably the best generalization that can be drawn is that VPE allows some pragmatic antecedents in some contexts. What is striking though is that NPE is perhaps equivalently as murky, suggestive still of their similarities.

⁹Note that Chao (1988) proposed a division of ellipsis types between VPE, sluicing, and Null Complement Anaphora (NCA) vs. gapping and stripping, where the former are H+ ellipsis, meaning the head of the phrase licensing the ellipsis is still present, and the latter are H- ellipsis, where the head has been elided. She shows a systematic set of distributional properties between the two. NPE patterns exactly like H+ ellipsis such as VPE on these grounds. If her typology is correct, then this is another argument that Ds head DPs since they are H+ ellipsis.

¹⁰This is a simplification of ?, where Ns do take possessor specifiers.

(11). In the next section, I'll demonstrate how deviant noun phrases, those missing either an N or a D, can be licensed.

5 Missing Elements

So far, the theory outlined here currently has no account for data like (22) where there is no overt D or N.

- (22) (a) (Some) angry wolves steal (some) rice. (Bare plural/mass N, non-overt D)
 (b) There's squirrel all over the road. (Bare count N (Universal Grinder), non-overt D)
 (c) Although most sportscasters are still optimistic, some *e* wonder if the Cubs will ever win the series. (Ellipsis, non-overt N)

For English, the data appear to cluster into two distinct types:¹¹

- (23) • Bare N with indefinite/generic reading (bare plural/mass interpretation adds D-semantics).
 • Bare D with anaphoric semantics (N-semantics supplied by ellipsis).

So far, Ds and NPs like those found in (22) are not well-formed NomPs:

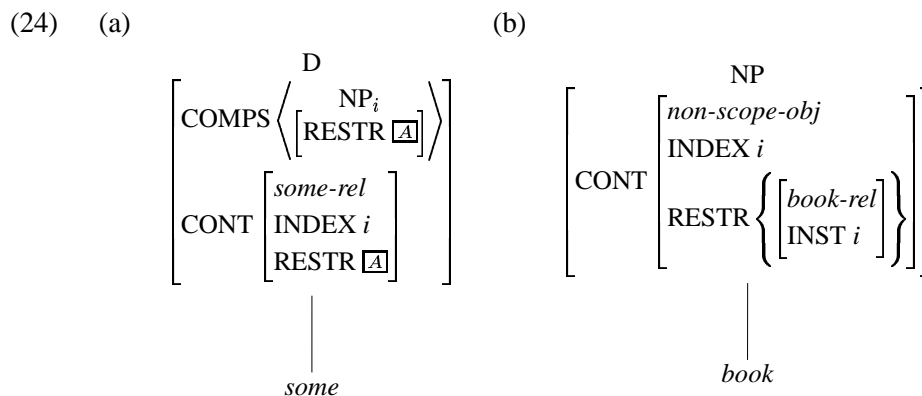

The problem isn't categorial since the common supertype of D and N allows either to head the NomP syntactically. However, there are semantic issues. The structure in (24a) is missing an N-semantic piece to satisfy the NPSWC in (11), as well as not being fully saturated. Likewise, the structure in (24b) is incomplete: although fully saturated it is lacking the D-semantics required of it to be a well-formed NomP. Following on this semantic anomaly, I'll propose the following informal analysis of bare nominals:

¹¹Although I'm not discussing proper names and pronouns it's worth pointing out that they satisfy a third part of this paradigm since they appear to come lexically packaged with D-semantics (definiteness) and only differ in whether they lexically have N-semantics (as in proper names) or acquire them through anaphoric reference (pronouns). Pronouns in particular optionally do show NP complements like determiners which may be unexpressed in ways other than ellipsis, something I'll return to in §6.

- (25) (i) The overt D or N is the syntactic head and supplies D or N-semantics respectively.
(ii) A specific interpretive processes (e.g. indefinite/generic pluralization or ellipsis) must supply the missing semantics to satisfy well-formedness.

The processes of bare nominalization and ellipsis needed in (22) can be encoded in a number of ways. For cases of bare NPs, we could simply modify the bare nominalization analysis of Ginzburg and Sag (2000) (ignoring AGR/COUNT features restricting the input to plurals/mass nouns):

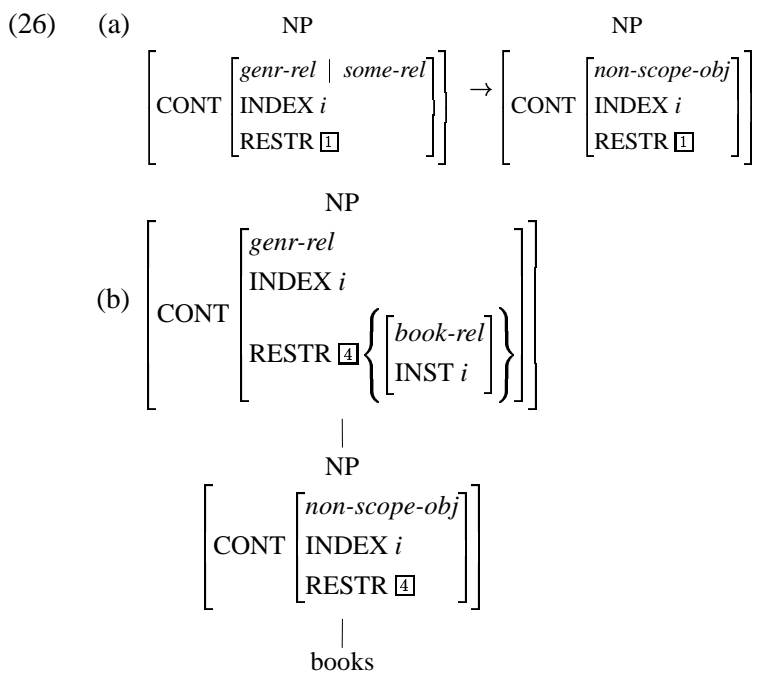

The rule in (26a) takes an NP without D-semantics as input and outputs a NomP with generic/indefinite D-semantics. An example application of this rule is given in (26b). The result of such a pumping rule is now a well-formed NomP: it is a fully saturated nominal category with D- and N-semantics. Note that this rule is largely semantic, operating purely on CONT values, something I'll return to momentarily. Turning to ellipsis, we can suppose because of the syntactic parallelism of D and Aux that NPE and VPE should be handled in parallel. Again, one simple account would be to adapt the VPE rule in Ginzburg and Sag (2000) as in (27a) to noun phrases (see also Hudson (1990)):

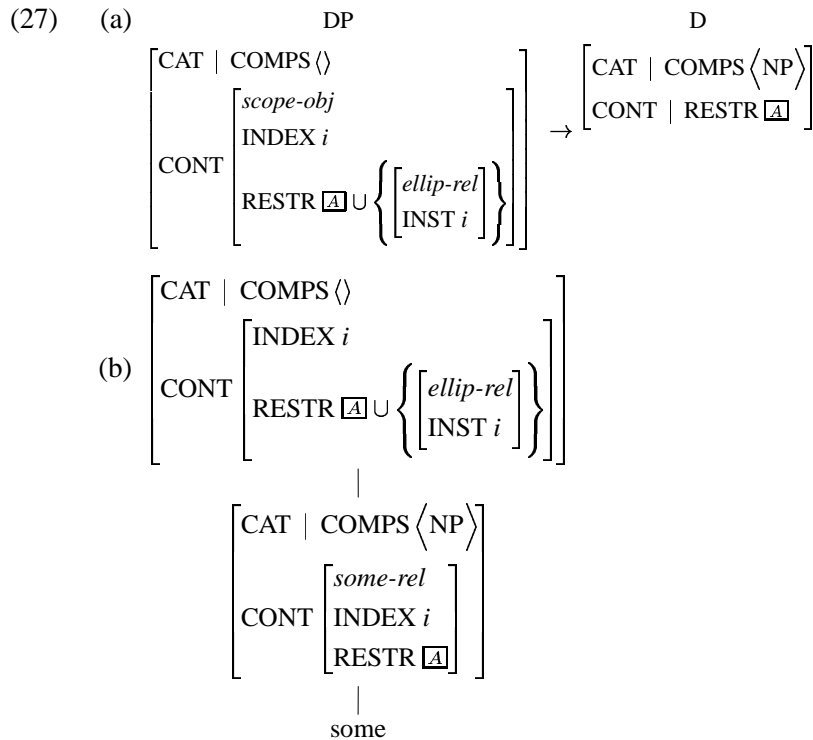

The NPE rule in (27a) takes a D without an NP complement, empties the COMPS list, and supplies a *nom-rel* in the RESTR of the output (the specific relation, *ellip-rel*, here just a place-holder for some elliptical semantics, the details of which are not relevant here). An example derivation is given in (27b). Again, the output of this rule is now a well-formed NomP, a fully saturated nominal phrase with D- and N-semantics. The close parallelism to the VPE rule in Ginzburg and Sag is telling; ideally, VPE and NPE could be done by one rule (as proposed in Jackendoff (1971)).¹² Via these two processes, we have an account of bare nominals and ellipsis that is at least no worse than, e.g., Ginzburg and Sag. Potentially, other missing D/N constructions cross-linguistically receive essentially equivalent treatments. Note that the rule in (27a), like (26a), is largely semantic, except for the syntactic component of emptying COMPS, and in the next section I will explore the possibilities of making both of these rules fully interpretive.

6 An All Semantic Approach

The analyses in the previous section are less than ideal since they involve non-branching pumping rules, i.e. syntactic machinery for which there is no overt syntactic evidence. Although frequently assumed in constructional approaches (see Ginzburg and Sag (2000)), they've also been argued against in terms of theoretical elegance (see e.g. Chomsky (1995)). In this section I'll argue that the two pumping rules can be eliminated by moving to an underspecified semantic representation.

¹²For instance by assuming an AUX-like feature for Ds/Auxs so that they form a natural class.

Note first that the rules in (26) and (27) operate almost exclusively on CONT values, save for the operation on CAT in the ellipsis rule. However, it's possible to eliminate the syntactic component of the ellipsis rule by assuming that Ds have optional complements, as in (28):

$$(28) \quad \det\text{-lxm} : \left[\begin{array}{l} \text{CAT} \left[\begin{array}{l} \text{HEAD } \textit{det} \\ \text{COMPS} \left\langle \left(\text{NP}_i \left[\text{RESTR } \boxed{A} \right] \right) \right\rangle \right. \\ \text{CONT} \left[\begin{array}{l} \textit{scope-obj} \\ \text{INDEX } i \\ \text{RESTR } \boxed{A} \end{array} \right. \end{array} \right. \end{array} \right]$$

This is not unmotivated: pronominal determiners *you/we* and deictic determiners *this/that/these/those* show optionality in complement selection (*we dogs/this (t-shirt)*). This is clearly not a process of ellipsis (i.e. it involves no “sense”-anaphoric reference) but instead resembles optional verb complements like *eat (a sandwich)* where the complement information is pragmatically inferred through some other means (as generic, definite, indefinite, etc.). Assuming optional complements for Ds means there's no need to change the CAT value in the ellipsis rule at all and then both rules in (26) and (27) would operate only on CONT values, thus being about as semantic as pumping rules can be given their inherently syntactic nature.

The advantage to this reconstrual is that it is also possible to eliminate the operations on CONT, and thus the pumping rules, by assuming an underspecified semantic representation, such as Minimal Recursion Semantics (see Copestake et al. (1999)). Among the many features of MRS is that it handles quantifier scope ambiguities by building representations that are underspecified for scopal relations between quantifiers, which can't be deduced from the syntax. Instead, some (potentially extra-grammatical) interpretive process incorporates a variety of grammatical, contextual, and pragmatic information to fully specify the scope relations. In a sense missing D- and N-semantics form a natural class with quantifier-scoping: they're semantic information which cannot be determined from the surface string. Following this parallelism, bare nominals/ellipsis can be treated just like quantifier scoping. On this approach, the grammar builds MRS structures that are simply underspecified for the missing D- or N-semantics. Rather than imposing the NPSWC syntactically as in (11), semantic well-formedness is a constraint on the processes that fully specify MRS structures: just as all fully specified MRS structures must be scope resolved, they must likewise have both D- and N-semantics for referential indices, as outlined in (29).

(29)	Process	Underspecified MRS	Fully Specified MRS
	Q-Scope	Underspecified scope	Must be scope resolved
	Ellipsis	Underspecified N-semantics	No vacuous quantification
	Bare NPs	Underspecified D-semantics	No free indices

Here the resolution of D- and N-semantics is localized to the mapping from underspecified MRS structures to fully specified ones, just as is done for quantifier scope resolution.¹³ (The processes that do the specification are presumably language specific, e.g. specifying D-semantics for English involves generic/indefinite interpretations, etc.) Thus the rules in (26) and (27) can be eliminated entirely. This is a theoretically desirable move: these pumping rules are essentially doing what specifying quantifier scope is doing in MRS, namely adding semantic information that can't be inferred from the syntax. Doing without the pumping rules puts the locus for specifying all underspecified semantics in one place instead of two.

This move also further supports the semantic well-formedness condition in (10) as the *only* condition necessary for noun phrase well-formedness. Pinning all of noun phrase well-formedness on semantics does beg some motivation, namely in answering the question: “why would we want an entirely semantic basis for noun phrase structure?” Here I think the answer comes from cross-linguistic syntax: not all languages have determiners, e.g. Estonian, Finnish, Japanese, Russian, etc., or else do not have the same class of determiners (compare English to Hungarian). Interpretation of D-semantics for these languages is based on other morphosyntactic or grammatical encodings as well as contextual, pragmatic, and distributional information. Any syntactic approach to noun phrase well-formedness (such as most strict headedness theories) inherently restricts the syntax to something less than universal since noun phrase structures vary so drastically cross-linguistically. The semantic approach sketched here does not fall prey to that. Assuming a cross-linguistic, universal semantic well-formedness condition for noun phrases with a single interpretive locus for specifying underspecified semantics (although with language specific processes) eliminates the need to posit any additional structure for languages for which it isn't attested.

7 Alternative Proposals with Multiple Heads

Before concluding it's worth comparing this approach to other approaches that have supposed that both D and N can head noun phrases in different contexts, e.g. Radford (1993), Netter (1994). Radford in particular proposes that D, N, Q(quantifier), and Adj are all “nominal” categories that embed one another recursively:

$$(30) \quad [_{DP} D [_{QP} Q [_{AdjP} Adj [_{NP} N XP]]]]]$$

Any substructure is a valid nominal phrase and heads share features (such as category features) via some form of feature passing. However, the process of feature passing and the notion of “nominal” categories receives no precise formulation in the Principles and Parameters framework Radford assumes; in a sense the HPSG analysis outlined here provides a precise way to encode these notions.

¹³The specific constraints imposed in (29) are familiar in more traditional representations like First-Order Logic (FOL) with GQs. The scoping constraints fall out of the recursive syntax for building FOL formulae, and the constraints against vacuous quantification and free variables are not unmotivated for some variants of FOL (see Dowty et al. (1981), Partee et al. (1990)).

Perhaps the most similar approach to the one outlined here is the HPSG account of Netter (1994), who proposes that D and N are functional and non-functional versions of the same category (see also Chomsky (1986), Abney (1987), Grimshaw (1991, 2000)). Ds select for Ns but Ns may project well-formed noun phrases, too, where the only condition on well-formedness is that a nominal projection must be “functionally complete”, i.e. must be [FCOMPL +], which Ds lexically are and Ns may acquire via bare pluralization. My approach has several advantages over Netter’s. First and foremost, the notion of “functional completeness”, which is given no linguistic definition at all, has been replaced with something grounded in uncontroversial observations about semantics (see also Hudson (2000) for a critique of functional categories). Second, the approach outlined above requires a minimal number of extra types (a part-of-speech supertype *nominal* and three extra semantic types above and beyond Ginzburg and Sag (2000), cf. Netter’s extensive type hierarchy) and no additional features (cf. Netter’s SPEC, FCOMPL, N, V, MAJOR, MINOR¹⁴), maybe even eliminating some features (see below). Therefore this approach has both conceptual and technical advantages over Netter’s.

8 Conclusion

The approach to noun phrase structure presented here also has several advantages over the NP approaches common in HPSG. First, looking at the technical advantages from an HPSG point of view, ellipsis is handled naturally (without null elements or category changing rules, cf. Nerbonne et al. (1989)), reducing the heterogeneity of grammatical information. Second, although I did not discuss this explicitly, the reformulation of the subcategorization properties of Ds allows us to eliminate the feature SPEC, used to pass semantic information from Ns to the Ds they take as specifiers in NP theories (Pollard and Sag, 1994). Furthermore, this approach moves us closer to eliminating the SUBJ/SPR distinction, largely motivated by predicative noun phrases which have both D specifiers and NP subjects, since now Ns do not take SPR values.

However, the real advantages to this approach aren’t so much technical, or necessarily empirical, as they are conceptual. First of all, this approach directly incorporates linguistic observations about the categorial relationship between D and N, something that isn’t ruled out in strict headedness approaches but is rarely directly encoded. Second, it makes no unattested categorical claims about noun phrase headedness, contra strict headedness approaches, since the cross-linguistic evidence does not provide a clear motivation for universally selecting either D or N as a head. Third, it paves the way for capturing the similarities between D and Aux, first noted in terms of gapping and ellipsis by Jackendoff (1971) and later in the DP literature following Abney (1987). Perhaps most significantly, this approach paves the way for grounding generalizations about well-formedness entirely in semantics and avoiding unnecessary syntactic operations. This has the nice result that the

¹⁴This SPEC is a boolean feature indicating whether something has picked up its specifier, not to be confused with the SPEC feature which passes semantic information from Ns to Ds in Pollard and Sag (1994).

same kinds of semantic processes can cover a wider range of languages, including those without Ds such as Estonian, Japanese, Russian, Finnish, etc., without positing unmotivated syntactic structure. Finally, this approach has potential to converge with other recent work collapsing the nominal part of speech hierarchy, in particular van Eynde (2003, this volume) and Sag et al. (in progress).

9 Acknowledgments

This paper first developed out of a study of \bar{N} -ellipsis in HPSG, ostensibly a difficulty in a theory without null categories where the N is considered the head. I'd like to thank Ivan Sag and Tom Wasow in particular for their help and guidance in developing these ideas. I'd also like to thank Emily Bender, Joan Bresnan, Luis Casillas, Liz Coppock, Iván García, Dick Hudson, Beth Levin, Stanley Peters, Geoff Pullum, Judith Tonhauser, Arnold Zwicky, and two anonymous reviewers for their help and comments. I'd especially like to thank Itamar Francez for his constant support and also for suggesting the topic to me in the first place (in the form of a challenge). Any errors and omissions in this paper are entirely my own.

References

- Abney, Steve. 1987. *The English Noun Phrase in its Sentential Aspect*. Ph.D. thesis, MIT.
- Barwise, Jon and Robin Cooper. 1981. Generalized quantifiers and natural language. *Linguistics and Philosophy*.
- Chao, Wynn. 1988. *On Ellipsis*. New York: Garland Publishing, Inc.
- Chierchia, Gennaro. 1998. Reference to kinds across languages. *Natural Language Semantics* (6):339–405.
- Chomsky, Noam. 1986. *Barriers*. No. 13 in Linguistic Inquiry Monograph. Cambridge, Mass.: MIT.
- Chomsky, Noam. 1995. *The Minimalist Program*. Cambridge, Mass: MIT Press.
- Copestake, Ann, Dan Flickinger, Ivan Sag, and Carl Pollard. 1999. Minimal recursion semantics: An introduction. <http://www-csli.stanford.edu/~acc/papers/newmrs.ps>.
- Croft, William. 1993. What is a head? In J. Rooryck and L. Zaring, eds., *Phrase Structure and the Lexicon*, pages 35–76. Dordrecht: Kluwer Academic Publishers.
- Dowty, David R., Robert E. Wall, and Stanley Peters. 1981. *Introduction to Montague Semantics*. Dordrecht: Reidel.
- Ginzburg, Jonathan and Ivan A. Sag. 2000. *Interrogative Investigations: The Form, Meaning, and Use of English Interrogatives*. CSLI Publications.
- Grimshaw, Jane. 1991. Extended projections. Unpublished ms., Brandeis Univer-

sity.

- Grimshaw, Jane. 2000. Locality and extended projection. In P. Coopmans, M. Everaert, and J. Grimshaw, eds., *Lexical Specification and Insertion*, pages 115–133. John Benjamins.
- Hankamer, Jorge. 1978. On the nontransformational derivation of some null np anaphors. *Linguistic Inquiry* 9(1).
- Hankamer, Jorge and Ivan Sag. 1976. Deep and surface anaphora. *Linguistic Inquiry* 7(3):391–428.
- Harris, Zellig. 1946. From morpheme to utterance. *Language* 22(3):161–183.
- Hudson, Richard. 1984. *Word Grammar*. Oxford: Basil Blackwell Publisher Limited.
- Hudson, Richard. 1987. Zwicky on heads. *Journal of Linguistics* 23(1):109–132.
- Hudson, Richard. 1990. *English Word Grammar*. Oxford: Basil Blackwell Publisher Limited.
- Hudson, Richard. 2000. Grammar without functional categories. In R. Borsley, ed., *The Nature and Function of Syntactic Categories*. Academic Press.
- Jackendoff, Ray. 1971. Gapping and related rules. *Linguistic Inquiry* 2(1).
- Jackendoff, Ray. 1977. *\bar{X} Syntax: A Study of Phrase Structure*. Cambridge: MIT Press.
- Lascarides, Alex and Ann Copestake. 1999. Default representation in constraint-based frameworks. *Computational Linguistics* 25(1):55–105.
- Longobardi, Giuseppe. 1994. Reference and proper names: A theory of n-movement in syntax and logical form. *Linguistic Inquiry* (25):609–665.
- Montague, Richard. 1974. The proper treatment of quantification in English. In R. Thomason, ed., *Formal Philosophy*, pages 247–270. New Haven: Yale University Press.
- Nerbonne, John, Masayo Iida, and William Ladusaw. 1989. Running on empty: Null heads in head-driven grammar. In E. J. Fee and K. Hunt, eds., *Proceedings of the Eight West Coast Conference on Formal Linguistics*. Stanford: CSLI.
- Netter, Klaus. 1994. Towards a theory of functional heads: German nominal phrases. In J. Nerbonne, K. Netter, and C. Pollard, eds., *German Grammar in HPSG*. Stanford: CSLI.
- Partee, Barbara H., Alice ter Meulen, and Robert E. Wall. 1990. *Mathematical Methods in Linguistics*. Dordrecht: Kluwer Academic Publishers.
- Payne, John. 1993. The headedness of noun phrases: Slaying the nominal hydra.

- In G. G. Corbett, N. M. Fraser, and S. McGlashan, eds., *Heads in Grammatical Theory*, pages 114–139. Cambridge: Cambridge University Press.
- Pollard, Carl and Ivan A. Sag. 1994. *Head-Driven Phrase Structure Grammar*. Chicago, IL: The University of Chicago.
- Postal, Paul. 1966. On so-called ‘pronouns’ in English. In *Georgetown Monographs on Languages and Linguistics*, pages 177–206. Georgetown University Press.
- Radford, Andrew. 1993. Head-hunting: On the trail of the nominal janus. In G. G. Corbett, N. M. Fraser, and S. McGlashan, eds., *Heads in Grammatical Theory*, pages 73–113. Cambridge: Cambridge University Press.
- Ross, John Robert. 1967. *Constraints on Variables in Syntax*. Ph.D. thesis, MIT. Published as *Infinite Syntax!*, Ablex, Norton, NJ, 1986.
- Sag, Ivan A., Charles Fillmore, Paul Kay, and Laura Michaelis. in progress. Some nominal constructions in English. Manuscript.
- Szabolcsi, Anna. 1987. Functional categories in the noun phrase. In I. Kenesei, ed., *Approaches to Hungarian 2*, pages 167–189. Jate Press Szeged.
- van Eynde, Frank. 2003. On the notion ‘determiner’. In S. Müller, ed., *Proceedings of the 2003 HPSG Conference*. Stanford, CA: CSLI Publications.
- Zwicky, Arnold M. 1985. Heads. *Journal of Linguistics* 21(1):1–29.
- Zwicky, Arnold M. 1993. Heads, bases, and functors. In G. G. Corbett, N. M. Fraser, and S. McGlashan, eds., *Heads in Grammatical Theory*, pages 292–315. Cambridge: Cambridge University Press.