

Towards Licensing of Adverbial Noun Phrases in HPSG

Beata Trawiński

University of Tübingen

Proceedings of the HPSG04 Conference

Center for Computational Linguistics  
Katholieke Universiteit Leuven

Stefan Müller (Editor)

2004

CSLI Publications

<http://csli-publications.stanford.edu/>

## Abstract

This paper focuses on aspects of the licensing of adverbial noun phrases (AdvNPs) in the HPSG grammar framework. In the first part, empirical issues will be discussed. A number of AdvNPs will be examined with respect to various linguistic phenomena in order to find out to what extent AdvNPs share syntactic and semantic properties with non-adverbial NPs. Based on empirical generalizations, a lexical constraint for licensing both AdvNPs and non-adverbial NPs will be provided. Further on, problems of structural licensing of phrases containing AdvNPs that arise within the standard HPSG framework of Pollard and Sag (1994) will be pointed out, and a possible solution will be proposed. The objective is to provide a constraint-based treatment of NPs which describes non-redundantly both their adverbial and non-adverbial usages. The analysis proposed in this paper applies lexical and phrasal implicational constraints and does not require any radical modifications or extensions of the standard HPSG geometry of Pollard and Sag (1994).

Since adverbial NPs have particularly high frequency and a wide spectrum of uses in inflectional languages such as Polish, we will take Polish data into consideration.

## 1 Introduction

Apart from adjectives, adverbs and relative and adverbial clauses, many languages use bare noun phrases for the purpose of modification (cf. (1) English and (2) German examples).

- (1) a. I will visit you *next week*.  
b. Do it *that way*.
- (2) a. Ich besuche dich *nächste Woche*.  
I visit you next week  
'I will visit you next week.'  
b. Er hat *den ganzen Weg* geschlafen.  
he has the whole way slept  
'He slept the whole way.'

In syntactic contexts such as those in (1) and (2), NPs such as the italicized NPs above clearly act as adjuncts, although, they are not prototypical modifiers.<sup>1</sup> Typically, they are used in syntactic structures as subjects and objects. This syntactico-functional variation indicates two different sets of syntactic and especially semantic properties. While adverbial NPs (AdvNPs) are assumed to act as semantic functors, as all modifiers do, non-adverbial NPs are usually considered as semantic

---

<sup>1</sup>I thank Adam Przepiórkowski, Frank Richter, Manfred Sailer, and the reviewers and audience of the HPSG04 Conference for their comments, and Guthrun Love for her help with English.

<sup>1</sup>Here, we will use the terms *adjunct* and *modifier* synonymously.

arguments. To capture these two sets of features properly, one could assume two lexical entries providing appropriate features for each noun that can appear both in adverbial and non-adverbial context. This strategy, however, would lead to redundancies in the lexicon.

In this paper we will attempt to treat this subject/complement–adjunct variation within the framework of HPSG in the tradition of Pollard and Sag (1994). We will propose an analysis of adverbial and non-adverbial NPs which captures their syntactic, lexico-semantic as well as combinatorial properties. Based on empirical observations, we will formulate an underspecification-based lexical constraint modeling both non-adverbial and adverbial nouns and we will provide a principle for a proper percolation of semantic information within structures containing AdvNPs.

The objective is to ensure the licensing of AdvNPs without any lexical rules and without an extension of the standard HPSG geometry. The analysis applies lexical and phrasal implicational constraints in terms of HPSG in the tradition of Pollard and Sag (1994) and enables a non-redundant description of the syntactico-functional variation of noun phrases.

AdvNPs such as those in (1) and (2) have particularly high frequency and a wide spectrum of uses in inflectional languages such as Polish. Hence, in this paper, we will take Polish data into consideration. The analysis proposed here for Polish data can be applied to NPs in other languages as well.

## 2 Empirical Generalizations

According to Szober (1969) and Urbańczyk (1978), among others, genitive, dative, accusative and instrumental NPs are possible in the adverbial function in Polish. While genitive AdvNPs are used for expressing temporal relations (see (3a)), dative AdvNPs denote for instance possessors (see (3b)), and accusative AdvNPs specify measure (see (3c)) and also time (see (3d)), instrumental AdvNPs are truly poly-functional (see (3e)–(3h)). There are particularly many semantic uses associated with relational instrumentals which necessarily take genitive complements, such as *celem* (‘for the purpose of’), *drogą* (‘by way of’), *kosztem* (‘at the expense of’), *względem* (‘because of’), etc. (cf. (3i)).

- (3) a. Jan odjechał *ostatniej nocy*. (time)  
 Jan left last<sub>gen</sub> night<sub>gen</sub>  
 ‘Jan left last night.’
- b. Maria wypiła *koledze piwo*. (possessor)  
 Maria drank colleague<sub>dat</sub> beer  
 ‘Maria drank colleague’s beer.’
- c. Jan zauważył Marię *metr przed sobą*. (measure)  
 Jan noticed Mary meter<sub>acc</sub> in front of him.  
 ‘Jan noticed Mary one meter in front of him.’

- d. Maria płakała *całą godzinę*. (time)  
 Maria cried whole<sub>acc</sub> hour<sub>acc</sub>  
 ‘Maria was crying for a whole hour.’
- e. Piotr uciekł *lasem*. (space)  
 Piotr escaped forest<sub>instr</sub>  
 ‘Piotr escaped through the forest.’
- f. Jan czyta *wieczorem*. (time)  
 Jan reads evening<sub>instr</sub>  
 ‘Jan reads in the evening.’
- g. Maria zabiła pająka *gazetą*. (means)  
 Maria killed spider newspaper<sub>instr</sub>  
 ‘Maria killed the spider with a newspaper.’
- h. Piotr odszedł *wolnym krokiem*. (manner)  
 Piotr went slow<sub>instr</sub> step<sub>inst</sub>  
 ‘Piotr went slowly.’
- i. Jan wyjechał *celem odpoczynku*. (goal)  
 Jan left purpose<sub>instr</sub> recreation<sub>gen</sub>  
 ‘Jan left for the purpose of recreation.’

In order to make appropriate generalizations about the distribution of Polish NPs in adverbial contexts, we will examine a range of AdvNPs with respect to determination and quantification, modification, pluralization and referentiality. The objective is to specify a set of syntactic and semantic properties that AdvNPs share with ordinary, non-adverbial NPs, and to determine properties that AdvNPs provide in contrast to ordinary NPs. Given this, we can determine whether we can describe NPs by means of only one lexical entry for each noun and what lexical constraints will be needed to license both uses of NPs.

In this paper we will focus exclusively on AdvNPs that modify VPs, leaving AdvNPs modifying NPs for a future work.

## 2.1 Morphological Cases in Polish

First of all we will give a short overview of morphological cases in Polish and state which cases can mark adverbial NPs.

There are seven morphological cases in contemporary Polish: nominative, genitive, dative, accusative, instrumental, locative and vocative. As we can see in Figure 1, four of the seven cases can mark AdvNPs.<sup>2</sup>

---

<sup>2</sup>The abbreviation RM in the gloss of the non-adverbial instrumental stands for a reflexive marker.

	NPs		AdvNPs
	<i>Jan śpi.</i>		
<i>nominative</i>	→ Jan is_sleeping 'Jan is sleeping.'	→ none	
<i>genitive</i>	→ Maria zażądała <i>pieniędzy.</i> Maria demanded money 'Maria demanded the money.'	→ Jan odjechał <i>tej nocy.</i> Jan left this night 'Jan left that night.'	
<i>dative</i>	→ Piotr dedykował swój doktorat <i>rodzicom.</i> Piotr dedicated his thesis parents 'Piotr dedicated his thesis to his parents.'	→ Maria wypita <i>Janowi</i> piwo. Maria drank John beer 'Maria drank John's beer.'	
<i>accusative</i>	→ Jan zobaczył <i>Marię.</i> Jan saw Maria 'Jan saw Maria.'	→ Maria płakata <i>całą godzinę.</i> Maria was crying whole hour 'Maria was crying for a whole hour.'	
<i>instrumental</i>	→ Jan posłużył się <i>nożem.</i> Jan used RM knife 'Jan used a knife.'	→ Piotr uciekł <i>lasem.</i> Piotr escaped forest 'Piotr escaped through the forest.'	
<i>locative</i>	→ Jan jest teraz w <i>szkole.</i> Jan is now in school 'Jan is in school now.'	→ none	
<i>vocative</i>	→ <i>Mamo, poczekaj!</i> mama wait 'Wait, mama!'	→ none	

Figure 1: Overview of morphological cases in Polish in the context of their use in adverbial and non-adverbial functions

While the Polish nominative is mainly used on subjects and predicative complements, the locative appears not freely, but rather as a prepositional object, and the vocative has a special, non-sentential status, genitive, dative, accusative and instrumental cases can be assigned to both argument NPs and adverbial NPs.<sup>3</sup>

Whereas the licensing of nominative-, locative- and vocative-marked nouns does not cause any problems and is rather unspectacular due to the compatibility of their syntactico-semantic features in each syntactic context in which these nouns may occur, an adequate and particularly non-redundant modeling of genitive-, dative-, accusative-, and instrumental-marked nouns seems more challenging.

Previous configurationally motivated approaches focus particularly on the aspects of case assignment to AdvNPs. Thus Emonds (1976), Bresnan and Grimshaw (1978) and McCawley (1988) treat AdvNPs as being embedded in a PP headed by a null preposition assigning case to those NPs. Larson (1985) argues against such a position, assuming that AdvNPs are bare NPs. However, since they are not governed by a case marking element, Larson (1985) proposes the feature specification [+F] for nouns heading adverbial NPs. In the case a NP cannot be structurally case marked (because it does not appear in a position governed by a case marking element), it is assigned its case from the case assigning feature specification [+F]. In contrast, Jaworska (1986) suggests a possibility based on the assumption that AdvNPs have no case at all.<sup>4</sup> However, based on Polish data, she assumes a specification of the form [CASE, INST], [CASE, GEN], and [CASE, ACC] in the lexical entry of each noun that can head an adverbial NP.<sup>5</sup> This strategy, however, leads to redundancies in the lexicon.

While most of the configurational studies on AdvNPs concentrate on case assignment, the constraint-based approach of Kasper (1997) discusses mainly combinatorial aspects of modifying and non-modifying NPs. In Section 3.2 we will work out the details of this approach.

In our strictly lexicalist approach, an analysis of NPs will be offered which captures both their syntactic, lexico-semantic as well as combinatorial properties. To do this we will examine AdvNPs with respect to a number of syntactic and semantic phenomena.

## 2.2 Determination and Quantification

In Polish, in contrast to English or German, there is no obligatory determination and quantification. NPs can occur in a sentence in a bare form. However, they are permitted to combine with determiners and quantifiers. We will examine below the ability of AdvNPs to select a determiner and a quantifier in order to find out

---

<sup>3</sup>For more details on morphological cases and case assignment in Polish, see Przepiórkowski (1999) for a constraint-based approach and Tajsner (1990) for a configuration-based approach.

<sup>4</sup>Her considerations apply to English bare NPs in an adverbial position and are based on the observation that those NPs never show any morphological variation, nor do they have any other properties that might be related to case.

<sup>5</sup>She does not make a statement about the dative case.

whether they behave analogically to non-adverbial NPs in this respect.<sup>6</sup>

- (4) a. Jan odjechał *\*(tej / pewnej) nocy*.  
 John left this<sub>gen</sub> some<sub>gen</sub> night<sub>gen</sub>  
 ‘John left that / some night.’
- b. Maria wypila *(temu / jakiemuś / każdemu) koledze piwo*.  
 Mary drank this<sub>dat</sub> some<sub>dat</sub> every<sub>dat</sub> colleague<sub>dat</sub> beer  
 ‘Mary drank this / some / every colleague’s beer.’
- c. Maria uczyła się *(tę / każdą) godzinę w domu*.  
 Mary studied RM this<sub>acc</sub> every<sub>acc</sub> hour<sub>acc</sub> at home  
 ‘Mary studied for that / every hour at home.’
- d. Piotr uciekł *(tym / jakimś) lasem*.  
 Peter escaped this<sub>instr</sub> some<sub>instr</sub> forest<sub>instr</sub>  
 ‘Peter escaped through this / some forest.’

As we can see in the examples above,<sup>7</sup> AdvNPs can occur both as bare NPs as well as in combination with determiners and quantifiers, and in this respect they behave like non-adverbial NPs. Only genitive AdvNPs show a behavior which is somewhat atypical for Polish NPs, not only permitting but requiring a determiner or a quantifier (cf. (4a)). In fact, genitive AdvNPs in Polish do not necessarily require a determiner or a quantifier. The presence of a modifier, such as *następny* (‘next’) or *pół* (‘half’), will also ensure the grammaticality of the sentence.<sup>8</sup>

### 2.3 Adjectival and Participial Modification

In this section we will examine whether AdvNPs can be modified by adjectives and adjectival participles, as are non-adverbial NPs.

- (5) a. Jan odjechał *\*(ostatniej / minionej) nocy*.  
 John left last<sub>gen</sub> past<sub>gen</sub> night<sub>gen</sub>  
 ‘John left last / past night.’
- b. Maria wypila *(niemieckiemu / spragnionemu) koledze piwo*.  
 Mary drank German<sub>dat</sub> thirsty<sub>dat</sub> colleague<sub>dat</sub> beer  
 ‘Mary drank the German / thirsty colleague’s beer.’
- c. Maria uczyła się *(całą / minioną) godzinę w domu*.  
 Mary studied RM whole<sub>acc</sub> past<sub>acc</sub> hour<sub>acc</sub> at home  
 ‘Mary studied for the whole / past hour at home.’

<sup>6</sup>In our approach we adopt the proposal of Pollard and Sag (1994) assuming a mutual selection in structures consisting of a determiner or a quantifier and a noun, and we assume that the syntactic head of the entire phrase of that form is a noun and not a determiner or a quantifier.

<sup>7</sup>The notation *\*(X)* as used in (4a) implies that the presence of X is necessary for the grammaticality of the sentence.

<sup>8</sup>This observation was also made in Szober (1969) and Jaworska (1986).

- d. Piotr uciekł (*gęstym / ciemnym*) *lasem*.  
 Peter escaped dense<sub>instr</sub> dark<sub>instr</sub> forest<sub>instr</sub>  
 ‘Peter escaped through the dense / dark forest.’

The examples in (5) show that genitive, dative, accusative and instrumental AdvNPs all allow adjectival and participial modification and that they behave like typical NPs in this respect. As mentioned in the previous section, genitive AdvNPs require a determiner or quantifier and/or a modifier. This fact is confirmed again by (5a).

Jaworska (1986) claims that accusative AdvNPs, similar to genitive AdvNPs, must contain modifiers, e.g. *cały* (‘whole’). However, examples such as those in (6) show that this requirement does not hold.

- (6) a. Maria pracowała *godzinę*.  
 Mary worked hour<sub>acc</sub>  
 ‘Mary worked for an hour.’  
 b. Piotr przebywał *miesiąc* w szpitalu.  
 Peter stayed month<sub>instr</sub> in hospital  
 ‘Peter stayed in a hospital for a month.’

## 2.4 Pluralization

If no formal and/or lexico-semantic restrictions are present, nouns can be pluralized in a straightforward way. Below we will test whether this holds for AdvNPs as well.

- (7) a. \*Jan odjechał *ostatnich noc*.  
 John left last<sub>gen, pl</sub> nights<sub>gen, pl</sub>  
 ‘John left last / past night.’  
 b. Maria wypila *kolegom piwo*.  
 Mary drank colleagues<sub>dat, pl</sub> beer  
 ‘Mary drank the colleagues’ beer.’  
 c. Maria uczyła się *całe godziny* w domu.  
 Mary studied RM whole<sub>acc, pl</sub> hours<sub>acc, pl</sub> at home  
 ‘Mary studied for entire hours at home.’  
 d. Piotr uciekał *lasami*.  
 Peter escaped forests<sub>instr, pl</sub>  
 ‘Peter escaped through forests.’

As we can see dative, accusative and instrumental AdvNPs can occur in plural form. In contrast, the occurrence of genitive plural AdvNPs seems to be either very restricted in Polish or not possible at all.<sup>9</sup> The ungrammaticality of (7a) can

<sup>9</sup>To our knowledge, there are no detailed studies on this issue so far.

be explained by the incompatibility of the semantic contribution of the adverbial genitive NP itself (as a point in time) and the semantics of plural.

## 2.5 Control of Relative and Personal Pronouns

In the following section, we will investigate AdvNPs with regard to referentiality. As an indication for referentiality, we will consider here the ability of a NP to control pronouns.

In (8), each AdvNP is modified by a relative clause.<sup>10</sup> As the indices show, both genitive, dative, accusative and instrumental AdvNPs are capable of controlling relative pronouns introducing relative clauses. This fact indicates that all AdvNPs in (8) are referential.

- (8) a. Jan odjechał *tej nocy<sub>i</sub>*, *której<sub>i</sub>* przybyła Maria.  
John left *this<sub>gen</sub> night<sub>gen</sub>* which arrived Mary  
'John left the night that Mary arrived.'
- b. Maria wypila piwo *koledze<sub>i</sub>*, *którego<sub>i</sub>* nie lubi.  
Mary drank beer colleague<sub>dat</sub> whom not likes  
'Mary drank the beer of the colleague whom she does not like.'
- c. Maria plakala *godzine<sub>i</sub>*, w ciagu *której<sub>i</sub>* spalila dziesiec papierosow.  
Mary cried hour<sub>acc</sub> during which smoked ten cigarettes  
'Mary was crying for an hour, during which she smoked ten cigarettes.'
- d. Piotr uciekl *lasem<sub>i</sub>*, *ktory<sub>i</sub>* dobrze znal.  
Peter escaped forest<sub>instr</sub> which well knew  
'Peter escaped through the forest which he knew well.'

The examples below confirm this assumption. Here each AdvNP in the first clause controls a personal pronoun in the second clause. This is indicated again by indexing.

- (9) a. Jan odjechał *tej nocy<sub>i</sub>*. Była ona<sub>i</sub> ciemna i deszczowa.  
John left *this<sub>gen</sub> night<sub>gen</sub>* was it dark and rainy  
'John left this night. It was dark and rainy.'
- b. Maria wypila *koledze<sub>i</sub>* piwo. Dlatego był on<sub>i</sub> zły.  
Mary drank colleague<sub>dat</sub> beer that's\_why was he angry  
'Mary drank the colleague's beer. That's why he was angry.'

---

<sup>10</sup>Except for the relative clause in (8c), all relative clauses in (8) are restrictive. We speculate that restrictive relative clauses modifying accusative AdvNPs are uncommon in Polish, but, in fact, there are no proper studies on this topic to our knowledge. In contrast genitive, dative and instrumental AdvNPs permit both restrictive and non-restrictive relative clauses to be modified by.

Since these facts do not affect our analysis and the treatment of relative clauses exceeds the scope of this paper, these aspects of modification will be ignored here. For previous analyses of relative clauses in the HPSG framework see e.g. Pollard and Sag (1994), Sag (1997), Holler-Feldhaus (2003) or Kiss (2004).

- c. Maria płakała *godzinę<sub>i</sub>*. Spaliła w ciągu niej<sub>i</sub> dziesięć papierosów.  
 Mary cried hour<sub>acc</sub> smoked during it ten cigarettes  
 ‘Mary was crying for an hour. She smoked ten cigarettes in that time.’
- d. Piotr uciekł *lasem<sub>i</sub>*. Znał go<sub>i</sub> dobrze.  
 Peter escaped forest<sub>instr</sub> knew it well  
 ‘Peter escaped through the forest. He knew it well.’

## 2.6 Summary of Empirical Observations

In the previous sections genitive, dative, accusative and instrumental AdvNPs have been examined with respect to determinability and quantifiability, modifiability, pluralizability and referentiality. Figure 2 summarizes the results of the applied tests.

	determination/ quantification	modification	pluralization	control
<i>genitive</i>	+	+	? / –	+
<i>dative</i>	+	+	+	+
<i>accusative</i>	+	+	+	+
<i>instrumental</i>	+	+	+	+

Figure 2: Summary of the results of tests applied to AdvNPs

Except for genitive AdvNPs, which always seem to require a determiner, a quantifier or an adjective, all other AdvNPs can occur both as bare NPs and NPs containing determiners, quantifiers and adjectives, and do not differ in this respect from non-adverbial NPs. Further on, all examined AdvNPs can appear in the plural form. Finally, every AdvNP can control pronouns. We can thus conclude that AdvNPs share their syntactic features with non-adverbial NPs and, since they can act as controllers as their non-adverbial counterparts do, they are referential objects. The crucial difference between adverbial and non-adverbial NPs seems to relate to their selectional and lexico-semantic properties.

In the next section, we will provide an HPSG account of AdvNPs that reflects these generalizations.

## 3 The Analysis

### 3.1 Lexical Licensing

According to the standard HPSG approach of Pollard and Sag (1994), adjuncts are treated as both syntactic and semantic selectors. The selection proceeds via the MOD feature appropriate for the sort *substantive* and thus for all objects of type *noun*. While the MOD feature’s value of adjuncts is of sort *synsem* (cf. Figure 3), the MOD feature of non-adjuncts is valued as *none* (cf. Figure 4).

$$\left[ \begin{array}{c} \text{word} \\ \text{SYNS} \left[ \text{LOC} \left[ \begin{array}{c} \text{CAT} \mid \text{HEAD} \mid \text{MOD:} \left[ \text{LOC} \mid \text{CONT} \boxed{1} \right] \\ \text{CONT} \mid \text{RESTR} \left\{ \left[ \text{NUCL} \mid \text{ARG} \boxed{1} \right] \right\} \end{array} \right] \right] \right] \end{array} \right]$$

Figure 3: Description of modifiers according to Pollard and Sag (1994)

$$\left[ \begin{array}{c} \text{word} \\ \text{SYNS} \left[ \begin{array}{c} \text{LOC} \left[ \text{CAT} \mid \text{HEAD} \mid \text{MOD:} \text{none} \right] \\ \text{CONT} \text{content} \end{array} \right] \right] \end{array} \right]$$

Figure 4: Description of non-modifiers according to Pollard and Sag (1994)

As shown in the previous sections, Polish genitive, dative, accusative, and instrumental NPs can occur both as adjuncts and as non-adjuncts, thus, the grammar must license nouns with the *synsem*-valued MOD attribute as well as nouns with the *none*-valued MOD attribute. Instead of specifying two separate lexical entries for each noun, we postulate one lexical entry for each noun with underspecified information about the MOD value and partially underspecified information about the CONTENT value. Further on, we propose an implicational lexical constraint containing each lexical entry as its antecedent and a disjunctive consequence ensuring the licensing of adverbial and non-adverbial nouns (cf. Figure 5).<sup>11</sup>

$$\forall \boxed{1} \forall \boxed{2} \left( \left[ \begin{array}{c} \text{word} \\ \text{SYNS} \left[ \text{LOC} \left[ \begin{array}{c} \text{CAT} \mid \text{HEAD} \mid \text{MOD:} \text{none} \\ \text{CONT} \left[ \begin{array}{c} \text{nom-obj} \\ \text{INDEX} \boxed{1} \\ \text{RESTR} \left\{ \boxed{2} \left[ \text{NUCL} \left[ \text{INST} \boxed{1} \right] \dots \right] \right\} \end{array} \right] \end{array} \right] \right] \right] \right] \rightarrow \left( \left[ \begin{array}{c} \text{word} \\ \text{SYNS} \left[ \text{LOC} \left[ \begin{array}{c} \text{CAT} \mid \text{HEAD} \mid \text{MOD:} \text{none} \\ \text{CONT} \left[ \begin{array}{c} \text{nom-obj} \\ \text{INDEX} \boxed{1} \\ \text{RESTR} \left\{ \boxed{2} \left[ \text{NUCL} \left[ \text{INST} \boxed{1} \right] \dots \right] \right\} \right] \right] \right] \right] \vee \left[ \begin{array}{c} \text{word} \\ \text{SYNS} \left[ \text{LOC} \left[ \begin{array}{c} \text{CAT} \mid \text{HEAD} \mid \text{MOD:} \left[ \text{LOC} \mid \text{CONT} \boxed{2} \text{psod} \right] \\ \text{CONT} \left[ \begin{array}{c} \text{nom-obj} \\ \text{INDEX} \boxed{1} \\ \text{RESTR} \left\{ \boxed{2} \left[ \text{NUCL} \left[ \text{INST} \boxed{1} \right] \dots \right] \right\} \right] \right] \right] \right] \right] \right) \end{array} \right)$$

Figure 5: Lexical Constraint for Licensing Adverbial and Non-Adverbial Nouns (preliminary version)

<sup>11</sup>For simplification we assume the RESTR set in the principle in Figure 5 to contain just one element. However, we do not intend to restrict the RESTR set of all nouns in the lexicon to be singleton sets.

The symbol  $\downarrow$  indicates that the attribute ARG is undefined. In SRL this is formalized as follows:  $\neg(\text{ARG} \approx \text{ARG})$ .

According to the above principle, MOD values of the two disjuncts in the consequence become specified. While the MOD value of the first disjunct is specified as *none* (for licensing non-adverbial nouns), the MOD value of the second disjunct is a *synsem* object (for licensing adverbial nouns).

Since both adverbial and non-adverbial NPs are able to bind pronouns, we assume both to be nominal objects containing an *index*.

Note also that the *psoa* object in the RESTR set of the non-adverbial nouns differs from *psoa* object in the RESTR set of the adverbial nouns. While the relation associated with non-adverbial nouns does not introduce any additional arguments, the relation associated with adverbial nouns introduces an argument whose value is identified with the semantics of the modified VP. This reflects the intuition that adverbial nouns in contrast to non-adverbial nouns act as semantic functors.

This analysis will presuppose a sort hierarchy for semantic relations associated with nouns of the form such as those in Figure 6.

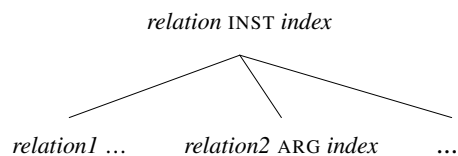

Figure 6: An exemplary sort hierarchy and feature declaration for semantic relations associated with nouns

### 3.2 Kasper (1997)

At this point we would like to address the approach to modification by Kasper (1997). He shows that the standard treatment of modification does not correctly handle modifiers that contain embedded modifiers and he provides a theory of modification that enables to represent the common meaning shared by different uses of the same expression as a modifier and a non-modifier.

For nouns such as *day* in English, which can act as complements (cf. (10a)) as well as modifiers (cf. (10b)) in syntactic structures,<sup>12</sup> he provides a lexical entry shown in Figure 7.<sup>13</sup>

- (10) a. Kim enjoyed *the day before yesterday*.  
 b. Kim left *the day before yesterday*.

<sup>12</sup>The examples in (10) are taken from Kasper (1997, p. 29).

<sup>13</sup>Note that the architecture of the lexical entry in Figure 7 differs from that used in the standard HPSG framework of Pollard and Sag (1994). The essential discrepancies concern the MOD and the RESTR values.

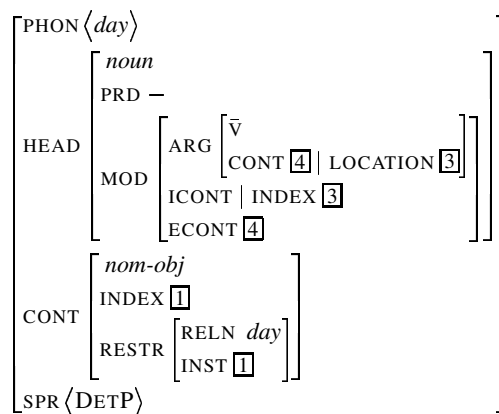

Figure 7: Description of the noun *day* according to Kasper (1997, p. 29)

Here the value of the MOD feature contains the feature ARG, which takes *synsem* as its value, the feature ICONT (internal content), which takes as its value the CONTENT value of the modifier's maximal projection, and the feature ECONT (external content), whose value is the semantic result of the functor-argument combination. The CONT attribute represents the inherent content that is specified for the lexical item.

The essential idea of this proposal is to distinguish the inherent meaning of a word or phrase from its uses in different constructions. In this theory the CONT attribute of a sign contains only its inherent semantic contribution. According to this, the CONT value of a noun used in an adverbial context is on par with the CONT value of this noun when used in a non-adverbial context. However, data such as those in (11) and (12) seem not to support this theory.

- (11) a. Maria obejrzała (cały) godzinny / czarno-biały / polski /  
 Mary watched whole one-hour black and white Polish  
 panoramiczny / pełnometrażowy film.  
 wide-screen feature film  
 'Mary watched a (whole) one-hour / black and white / Polish / wide-  
 screen / feature film.'
- b. Maria płakała \*(cały) godzinny / #czarno-biały / #polski /  
 Mary cried whole one-hour black and white Polish  
 #panoramiczny / #pełnometrażowy film.  
 wide-screen feature film  
 'Mary was crying the whole one-hour / #black and white / #Polish /  
 #wide-screen / #feature film.'
- (12) a. Jan uszkodził asfaltową / #męczącą drogę.  
 John damaged asphalt exhausting road  
 'John damaged an asphalt / #exhausting road.'

- b. Jan spał całą tą #asfaltową / męczącą drogę.  
 Jan slept whole this asphalt exhausting road  
 ‘John was sleeping the whole #asphalt / exhausting trip.’

The (un)acceptability of the sentences above seems to relate to the (in)compatibility of lexical meanings contributed by the adjectives and the nouns. The noun *film* (‘film’) in (11) and the noun *droga* (‘way’) in (12) show in (11a) and (11b) and in (12a) and (12b) respectively different preferences with respect to adjectives they combine with. Assuming one inherent meaning for a given noun, as Kasper (1997) does, this phenomenon cannot be explained. The examples in (11) and (12) seem to indicate that adverbial nouns in (11b) and (12b) introduce a different lexico-semantic meaning to their non-adverbial counterparts in (11a) and (12a).<sup>14</sup>

Thus, unlike Kasper (1997), who does not consider these lexical ambiguities, we find it reasonable to assume different semantic relations for adverbial and non-adverbial uses of a given noun, that is not to have one fix CONTENT value for each use of a given noun.

### 3.3 Problems of Structural Licensing

Given the Lexical Constraint for Licensing Adverbial and non-Adverbial NPs in Figure 5 and by virtue of the HEAD-ADJUNCT SCHEMA of Pollard and Sag (1994), phrasal structures containing AdvNPs can be licensed (cf. Figure 8).

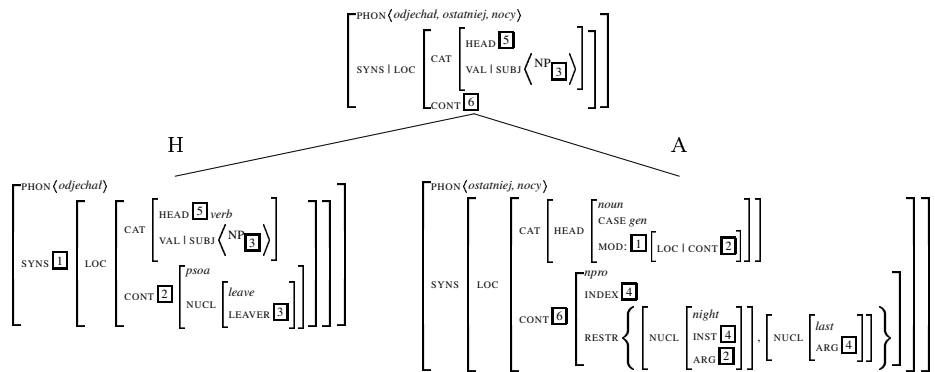

Figure 8: Description of the VP *odjechał ostatniej nocy* (‘left last night’)

The HEAD-FEATURE PRINCIPLE and the HEAD-ADJUNCT SCHEMA ensure the percolation of the head and subcategorization information along the phrase structure. However, the determination of the CONTENT value of the mother node (6) is questionable. According to the SEMANTICS PRINCIPLE of Pollard and Sag

<sup>14</sup>Note that we do not indent to indicate that a lexical meaning of a given noun is associated with some syntactic context. The distribution of nouns such as *droga* (‘way’) with the temporal meaning is not limited to the adverbial position. These nouns can also act as subjects and complements if their lexical meaning is compatible with the lexical meaning of the predicate.

(1994), the CONTENT value of the mother is token-identical to the CONTENT value of the adjunct daughter. In the case of the VP in Figure 8, this would then be the CONTENT value of the AdvNP *last night*. According to our intuition, however, the entire VP denotes an event rather than a nominal object.

In contrast, working in Davidsonian style, i.e. introducing an event variable into the semantic representation of verbs<sup>15</sup> and assuming an architecture of the CONTENT value of verbs analogous to that of nouns,<sup>16</sup> we can avoid these technical and conceptual problems. Thus, in our approach we assume that the CONTENT value of a verb is an object containing both an (event) index and a semantic restriction of this index (cf. Figure 9).

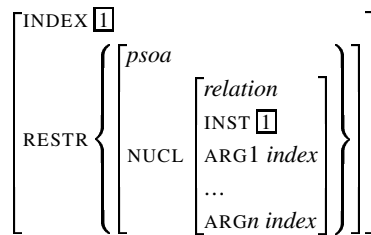

Figure 9: The *content* structure of verbs in Davidsonian style

Given this, the Lexical Constraint for Licensing Adverbial and Non-Adverbial Nouns in Figure 5 has to be reformulated. The ARG values of adverbial nouns are now token-identical to the INDEX value of the modified VP, and the value of the RESTR feature of an adverbial noun is a union of its own RESTR set and the RESTR set of the modified VP (cf. Figure 10).

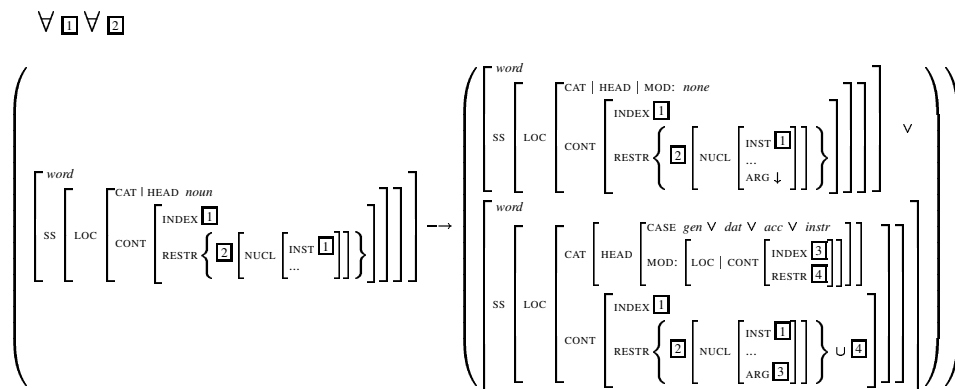

Figure 10: Lexical Constraint for Licensing Adverbial and Non-Adverbial Nouns

<sup>15</sup>Cf. Davidson (1967).

<sup>16</sup>Cf. Van Eynde (1998) or Sag and Wasow (1999) for a similar approach to the representation of the verbal semantics.

At this point we will turn to our generalizations about genitive AdvNPs. In Section 2.2 and Section 2.3 we have mentioned that genitive AdvNPs require a determiner, a quantifier and/or a modifier. This observation is formalized by means of the constraint in Figure 11, which says that if a genitive noun modifies an object then it has either to have a non-empty SPR list or its RESTR set has to contain at least two *psoa* objects, one of which is an inherent *psoa* object introduced by this noun and the second one is a *psoa* object associated with an adjective.

$$\forall \boxed{1} \forall \boxed{2} \left( \left[ \begin{array}{c} \text{word} \\ \text{SYNS} \left[ \begin{array}{c} \text{LOC} \left[ \begin{array}{c} \text{CAT} \left[ \begin{array}{c} \text{HEAD} \left[ \begin{array}{c} \text{noun} \\ \text{CASE } \textit{gen} \\ \text{MOD } \textit{synsem} \end{array} \right] \\ \text{VAL} \mid \text{SPR } \boxed{1} \end{array} \right] \\ \text{CONT} \mid \text{RESTR } \boxed{2} \end{array} \right] \end{array} \right] \end{array} \right] \end{array} \right] \rightarrow (\boxed{1} \textit{nelist} \vee \boxed{2} \{ \textit{psoa}, \textit{psoa}, \dots \}) \end{array} \right)$$

Figure 11: Restrictions on adverbial genitives

We have also mentioned that genitive AdvNPs occur mainly (or even exclusively) in the singular form. This restriction can easily be integrated into the constraint in Figure 11. However, we are based on the assumption that this restriction is a natural consequence of independent semantic constraints.

Now we are able to reformulate the SEMANTICS PRINCIPLE so that it ensures the right percolation of semantic information along the structure.

As we have already mentioned, the INDEX value of the entire VP is expected to be token-identical to that of the head daughter. The collection of all semantic restrictions on that event is located within the adjunct daughter and is expected to be present at the mother node. This observation indicates that the RESTR value of the mother has to be token-identical to that of the adjunct daughter. Thus new SEMANTICS PRINCIPLE is as follows:

(13) SEMANTICS PRINCIPLE

In a headed phrase, the SYNSEM | LOCAL | CONTENT | INDEX value is token-identical to that of the head daughter and the SYNSEM | LOCAL | CONTENT | RESTR value is token-identical to that of the adjunct daughter, if any, and to the head daughter otherwise.

Note that the SEMANTICS PRINCIPLE in (13) corresponds to two semantic principles proposed in Sag and Wasow (1999) (cf. (14) and (15)), however it is formulated in terms of the standard HPSG framework of Pollard and Sag (1994).

(14) SEMANTIC COMPOSITIONALITY PRINCIPLE

In any well-formed phrase structure, the mother's RESTR value is the sum of the RESTR values of the daughters.

(15) SEMANTIC INHERITANCE PRINCIPLE

In any headed phrase, the mother's MODE and INDEX values are identical to those of the head daughter.

The SEMANTICS PRINCIPLE as defined in (13) is not only motivated by the licensing of phrases with AdvNPs as adjunct daughters. Besides all other structures it will make also accurate predictions about the semantics of NPs, such as *a written book*, which cannot be handled properly in the standard HPSG approach without additional stipulations (e.g. without appropriate lexical rules). It is obvious that this NP refers to a book object rather than to a writing event. However, the SEMANTICS PRINCIPLE of Pollard and Sag (1994) will provide an unexpected interpretation of this NP by identifying the CONTENT value of the entire NP with the CONTENT value of the adjunct daughter, which refers to the event of writing. In contrast, the SEMANTICS PRINCIPLE proposed here will ensure identities between the INDEX values of the mother and the head daughter and between the RESTR values of the mother and the adjunct daughters, thus licensing the expected denotation of the entire NP.

By virtue of the SEMANTICS PRINCIPLE in (13) and the the Lexical Constraint for Licensing Adverbial and Non-Adverbial Nouns in Figure 10, VPs such as *odjechał ostatniej nocy* ('left last night') in Figure 12 can be licensed with a correct syntactic and semantic representation.

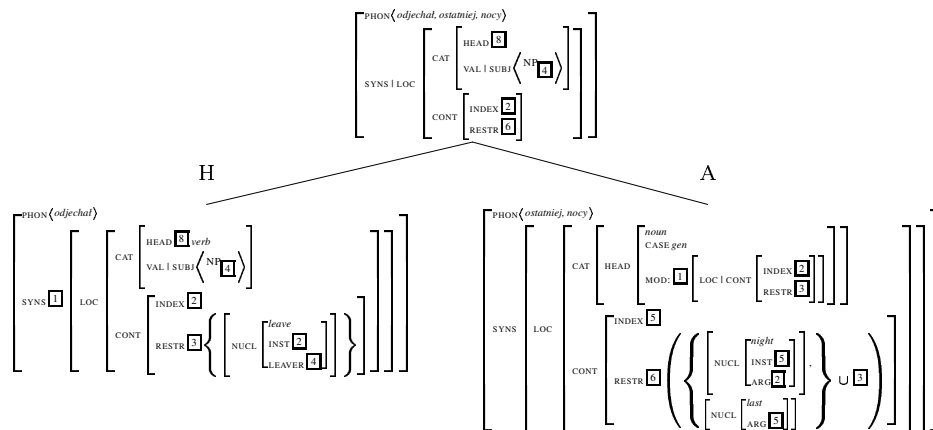

Figure 12: Description of the VP *odjechał ostatniej nocy* ('left last night')

The genitive noun *nocy* ('night') in Figure 12 is licensed by the Lexical Constraint for Licensing Adverbial and Non-Adverbial Nouns in Figure 10. By virtue of the restrictions on adverbial genitive nouns formulated in the constraint in Figure 11, the noun *nocy* ('night') must combine with the adjective *ostatniej* ('last'). The genitive NP modifies the verb *odjechał* ('left') via the feature MOD in the way proposed in Pollard and Sag (1994). Due to the uniform architecture of CONTENT value of nouns and verbs and according to the SEMANTICS PRINCIPLE in

(13), the INDEX value of the entire VP *odjechał ostatniej nocy* ('left last night') is token-identical with the INDEX value of the head daughter, that is of the verb, and the RESTR value of the VP is token-identical with the REST value of the adjunct daughter, that is of the AdvNP.

## 4 Summary and Outlook

In this paper, we have discussed various aspects of the licensing of adverbial NPs within the HPSG grammar framework. Based on the results of applying a range of syntactic and semantic tests to Polish AdvNPs, we have made the generalization that AdvNPs share syntactic features and the property of referentiality with non-adverbial NPs but differ from them in selectional properties.

In Section 3 we have provided a lexical principle for licensing adverbial and non-adverbial nouns, and we discussed problems with the percolation of semantic information along the complex structures involving AdvNPs in the HPSG approach of Pollard and Sag (1994). We have finally provided a principle that ensures correct semantic predictions. By the use of the underspecification-based lexical principle in Figure 10 and the SEMANTICS PRINCIPLE in (13), the modeling of both adverbial and non-adverbial NPs is enabled without the need for introducing lexical rules or extending the standard HPSG geometry and without any redundancies in the lexicon. Our approach shows again that implicational constraints as used in HPSG, also at the level of the lexicon, are an efficient mechanism for describing linguistic phenomena.

The above investigations focused on syntactic and compositional-semantic aspects of the AdvNP grammar leaving lexico-semantic factors untouched. However, an additional lexico-semantic treatment of AdvNPs will be needed to exclude over-licensing.

## References

- Bresnan, Joan W. and Grimshaw, Jane. 1978. The Syntax of Free Relatives in English. *Linguistic Inquiry* 9, 331–391.
- Davidson, Donald. 1967. The Logical Form of Action Sentences. In Nicholas Rescher (ed.), *The Logic of Decision and Action*, Pittsburgh: University of Pittsburgh Press.
- Emonds, Joseph E. 1976. *A Transformational Approach to English Syntax: Root, Structure-preserving, and Local Transformations*. Academic Press.
- Holler-Feldhaus, Anke. 2003. An HPSG Analysis of the non-Integrated wh-Relative Clauses in German. In *Online Proceedings of the Tenth International Conference on HPSG, CSLI*.

- Jaworska, Ewa. 1986. *Aspects of the Syntax of Prepositions and Prepositional Phrases in English and Polish*. Ph. D.thesis, University of Oxford.
- Kasper, Robert. 1997. *Semantics of Recursive Modification*, manuscript, version of October 29, 1997.
- Kiss, Tibor. 2004. *Semantic Constraints on Relative Clause Extraposition*. To appear in the *Natural Language and Linguistic Theory*.
- Larson, Richard K. 1985. Bare NP-Adverbs. *Linguistic Inquiry* 16, 595–621.
- McCawley, James D. 1988. Adverbial NPs: Bare or Clad in See-Through Garb? *Language* 64, 583–590.
- Pollard, Carl J. and Sag, Ivan A. 1994. *Head-Driven Phrase Structure Grammar*. Chicago: The University of Chicago Press.
- Przepiórkowski, Adam. 1999. *Case Assignment and the Complement-Adjunct Dichotomy: A Non-Configurational Constraint-Based Approach*. Ph. D.thesis, University of Tübingen.
- Sag, Ivan A. 1997. English Relative Clause Constructions. *Journal of Linguistics* 33, 431–483.
- Sag, Ivan A. and Wasow, Thomas. 1999. *Syntactic Theory: A Formal Introduction*. CSLI Publications.
- Szober, Stanisław. 1969. *Gramatyka języka polskiego [The Grammar of Polish Language]*. Warszawa: PWN.
- Tajsner, Przemysław. 1990. *Case Marking in English and Polish: A Government and Binding Study*. Ph. D.thesis, Uniwersytet im. Adama Mickiewicza, Poznań, Poland.
- Urbańczyk, Stanisław (ed.). 1978. *Encyklopedia wiedzy o języku polskim [Encyclopedia of the Knowledge of Polish Language]*. Wrocław, Warszawa, Kraków, Gdańsk: Wydawnictwo Zakładu Narodowego im. Ossolińskich.
- Van Eynde, Frank. 1998. Tense, Aspect and Negation. In F. Van Eynde and P. Schmidt (eds.), *Linguistic Specifications for Typed Feature Structure Formalisms. Studies in Machine Translation and Natural Language Processing*, volume 10, pages 209–280, Luxembourg: Office for Official Publications of the European Communities.