

Towards A Semantic Analysis of Argument/Oblique
Alternations in HPSG

John Beavers

Dept. of Linguistics and CSLI
Stanford University
Stanford, CA, 94305-2150

Proceedings of the HPSG05 Conference

Department of Informatics, University of Lisbon

Stefan Müller (Editor)

2005

CSLI Publications

<http://csli-publications.stanford.edu/>

Abstract

I examine the semantic contrasts exhibited by argument/oblique alternations (argument realization alternations where one or more participants may be realized either as a direct argument or an oblique). Previous HPSG accounts of these have proposed that alternating verbs are ambiguous, where each variant has a structured semantics that makes different participants more or less structurally prominent in the semantic representation. I argue that such accounts fail to capture the full richness of the contrasts exhibited by such alternations, and propose instead a model that derives alternations from the lexical entailments each verb associates with the alternating participant.

1 Introduction

In this paper I outline a semantic analysis of what I refer to as argument/oblique alternations, in which a verb selects for one or more participants that may be realized either as a direct argument or as an oblique (Levin 1993). Following Beavers (to appear b), I argue that when such alternations exhibit semantic contrasts it is always in terms of the relative number of entailments associated with the alternating participant and I sketch a framework for capturing this in HPSG.¹ I use as my primary case study the locative alternation (Fillmore 1968), as exemplified in (1).

- (1) a. John loaded the hay onto the wagon. (locatum=DO, location=oblique)
b. John loaded the wagon with the hay. (location=DO, locatum=oblique)

In (1a) the locatum (the thing moved) is realized as the direct object and in (1b) it is realized as an oblique marked by *with*. Conversely, in (1a) the location is realized as an oblique but as the direct object in (1b). Many semantic properties associated with each participant are **invariant** across both variants, e.g. one participant is always a location that comes to contain the locatum, while the other is always a locatum that comes to rest in or on the location. However, the classic observation (see Anderson 1971) is that whichever participant is realized as the direct object receives a “holistically affected” interpretation (all moved or loaded up):

- (2) a. John loaded the hay onto the wagon, but left some space for the grain.
b. #John loaded the wagon with the hay, but left some space for the grain.
(3) a. John loaded the wagon with the hay, but left some to fill the truck.
b. #John loaded the hay onto the wagon, but left some to fill the truck.

[†]I would like to acknowledge the support of NTT and the LinGO project at CSLI in the development of this work. I would also like to thank Doug Ball, Dan Flickinger, Valia Kordoni, Beth Levin, Carl Pollard, Mika Poss, Ivan Sag, and three anonymous reviewers for their comments.

¹This is part of a larger study based on a theory of thematic roles as sets of entailments, following Dowty (1991). I use “entailment” in the sense of Dowty’s (1989) “lexical entailment”, i.e. properties a verb ascribes to an entity due to its role in the event. See Beavers (to appear b) for more details on the English data motivating this analysis and previous semantic work on alternations.

In (2b) and (3b) the direct object realizations of both participants are infelicitous in contexts in which holistic affectedness does not obtain for that participant. In (2a) and (3a), however, the oblique realizations are compatible with contexts in which holistic affectedness does not obtain (and those in which it does). Thus the oblique realizations are **underspecified** for holistic affectedness: it is neither entailed nor contradicted. Although the locative alternation and holistic affectedness have been discussed extensively in previous literature (usually with respect to the verbs *load* and *spray*), other verbs not normally considered to be locative alternating verbs participate in a morphosyntactically similar paradigm with a related but distinct semantic contrast, as shown in (4) for the verb *cut*.

- (4) a. John cut his hand on the rock. (hand affected; rock not necessarily)
 b. John cut the rock with his hand. (rock affected; hand not necessarily)

Again there are locatum and location participants which appear to alternate between direct object and oblique realization, and again there is a semantic contrast having to do with affectedness. However, here the contrast is in simple affectedness: in both cases the direct objects are affected in some way, while the corresponding obliques are not necessarily affected at all. There is no sense in which “holistic” affectedness plays a role. However, the morphosyntactic similarities suggest that (1) and (4) may be two manifestations of the same alternation, as does the fact that both alternations involve underspecification of the degree of affectedness (similar points are also made by Fillmore 1977, Gawron 1986, and Dowty 1991).

We also see underspecificity contrasts in the dative alternation. Ditransitive verbs are subcategorized for an agent, a theme, and a goal/recipient that may be realized either as a first object or as a *to*-oblique. In both variants the goal/recipient is invariably a (physical or abstract) goal of the “motion” of the theme, but when it is a first object it carries the additional semantics of coming to possess the theme (Pesetsky 1995, Harley 2003). This is illustrated in (5), where an inanimate first object is infelicitous unless construed of as being somehow capable of possession.

- (5) a. John sent a letter to London. (Location or “London Office” reading)
 b. John sent London a letter. (Only “London Office” reading).

The oblique variant is underspecified for possession (cf. (5a) is compatible with both a “London office” and a locational London reading) but the first object variant requires it (forcing a “London office” reading), while both variants invariably involve a goal of some sort (in both cases London corresponds to the endpoint of the movement of the letter). Similar underspecificity relationships in fact hold for numerous other alternations, including those in (6)-(12) (Beavers to appear b).

- (6) **Reciprocal alternation** (Underspecified motion)
 a. The car and the truck collided. (car and truck in motion)
 b. The car collided with the truck. (car in motion; truck not necessarily)

- (7) **Conative alternation I** (Underspecified holistic affectedness)
 a. John ate the sandwich. (sandwich all eaten)
 b. John ate at the sandwich. (sandwich not necessarily all eaten)
- (8) **Conative alternation II** (Underspecified affectedness)
 a. John slashed the canvas. (canvas affected)
 b. John slashed at the canvas. (canvas possibly not affected)
- (9) **Dative alternation w/Ballistic Motion** (Underspecified possession/goal)
 a. John threw Mary the ball. (Mary a goal and possessor)
 b. John threw the ball to Mary. (Mary not necessarily possessor)
 c. John threw the ball at Mary. (Mary not necessarily goal or possessor)
- (10) **Preposition drop alternation** (Underspecified holistic traversal)
 a. John climbed the mountain. (entire mountain traversed)
 b. John climbed up the mountain. (mountain possibly not all traversed)
- (11) **Search alternation I** (Underspecified existence)
 a. John hunted a unicorn in the woods. (unicorn presupposed to exist)
 b. John hunted (in) the woods for a unicorn. (unicorn might not exist)
- (12) **Search alternation II** (Underspecified holistic coverage)
 a. John searched the woods for deer. (woods totally searched)
 b. John searched in the woods for deer. (woods maybe not all searched)

In each case the direct argument is specified for a semantic property left underspecified for the corresponding oblique, where the exact semantic contrast varies but includes motion, affectedness, possession, total traversal, etc. Thus an adequate analysis of alternations must capture the following generalization:

- (13) Direct argument variants entail more about the alternating participant than oblique variants.

Furthermore, the exact contrasts are simultaneously verb, verb-class, and alternation specific. For example, for all “locative” alternations the underspecified property is the degree of affectedness. But the exact degree of affectedness varies, and verbs cluster into classes. For *load* (also *spray* and *smear*) the contrast has to do with holistic affectedness, while for *cut* it has to do with simple affectedness. Finally, within a class, each verb associates different entailments with different variants. When the location participant of *spray* is the direct object it is specified for total surface area coverage by the locatum, whereas when the location participant of *load* is the direct object it is specified for having reached maximum containment (e.g. all filled up with the locatum). Ideally a theory of alternations should capture (13) in a way that admits lexical and alternation specific idiosyncrasy.

2 Previous HPSG Approaches

Previous HPSG analyses have generally failed to capture (13), typically by not providing a rich enough semantics to capture the contrasts. I focus here on the work of Davis and Koenig (Davis and Koenig 2000, Davis 2001, Koenig and Davis 2003, 2004), by far the most influential work on argument realization in HPSG. One of the key motivations for Davis and Koenig’s theory is the elimination of unnecessary and independently unmotivated constructs (such as thematic role hierarchies and complex predicate decompositions) in favor of the simplest possible link between lexical semantics and argument realization (see Davis 2001:25ff). In principle, such a theory involves only argument structure on the one hand and verb-specific entailments constituting the verb’s lexical semantics on the other, where the entailments determine how each participant is realized in the argument structure. Davis and Koenig (2000) and Davis (2001), however, argue that to capture certain generalizations an intermediate level of semantic representation is necessary, namely predicate decompositions that encode reified proto-roles in the Dowty (1991) sense. I do not focus here on their specific arguments for a tripartite linking theory, but instead on their analysis of the locative alternation to show that it does not provide a direct way of capturing the subtle contrasts argued for above.²

Following the predicate decomposition approaches of Levin and Rappaport (1988) and Pinker (1989) (among others), Koenig and Davis (2004) assume that locative alternating verbs are polysemous between a change of location reading (where the locatum comes to be moved) and a change of state by means of a change of location reading (where the location changes state because the locatum is moved into some configuration with it). They encode this via two lexical entries for each verb, as shown in (14) for *spray* (cf. Koenig and Davis 2004:30, Fig. 25).

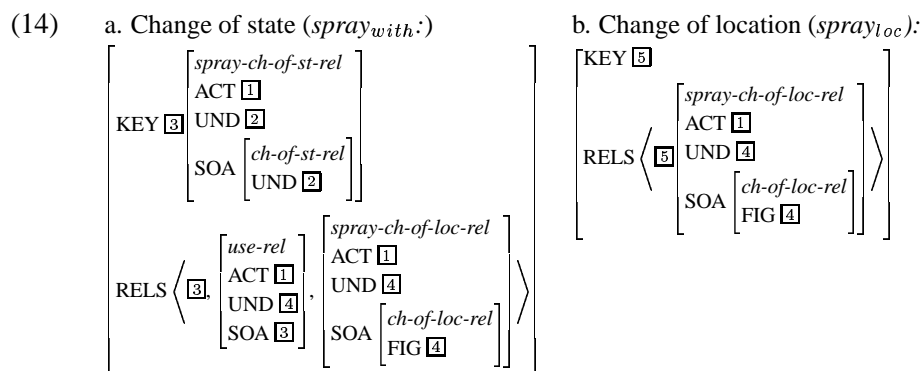

²Davis and Koenig (2000) and Davis (2001) bring up several arguments against purely entailment based linking theories, focusing almost entirely on Dowty (1991). They argue against such a theory based primarily on the fact that (a) some entailments, such as those having to do with causation, can outrank or trump others in subject selection, (b) there exist certain counterexamples to Dowty’s proposed proto-role entailments, and (c) Dowty’s theory only addresses transitive verbs. However, most of their criticisms are specific to Dowty’s proposal and do not necessarily constitute general arguments against a sufficiently fleshed out entailment based theory. This paper and Beavers (to appear b), in fact, specifically address point (c) in such a theory.

Each entry has a different *elementary-predication* (EP) from its REL(ATION)S list as its KEY value, representing the two possible meanings associated with such verbs. In (14a) the *spray-ch(ange)-of-st(ate)-rel* is the KEY value, whereas in (14b) it is the *spray-ch-of-loc-rel*. The different KEY choices mean that different participants are linked to the KEY.UND(ERGOER) attributes: in (14a) the location is the KEY.UND, while in (14b) it is the locatum. On Koenig and Davis’s approach, KEY.UND is always linked to the direct object on ARG-ST, meaning that each variant realizes a different participant as the direct object, thus capturing the alternation.³ However, this approach so far fails to capture the semantic contrast since no entailment of holistic affectedness (or its absence) is encoded anywhere in (14).

In earlier work Davis and Koenig (2000) and Davis (2001) argue that the UND attribute is associated with various verb-specific “characteristic entailments”, roughly corresponding to Dowty’s (1991) proto-patient entailments (e.g. “incremental theme”). On this approach the presence of at least one such entailment is in fact a necessary condition for the presence of the UND attribute in the CONT value of the verb (e.g. Davis’s 2001:81 “attribute-to-entailment condition”). If such entailments underlie KEY.UND, we could simply stipulate that KEY.UND must be associated with characteristic entailments that are underspecified for other patientive attributes, thus capturing (13) (cf. a related, non-MRS analysis of alternations in causee realization in Spanish in Davis 2001, where linking to an UND feature at the highest level of decomposition corresponds to how affected the causee is).

However, this approach presents several problems. First and foremost, it fails to explain in a general way which entailments vary for each verb, verb class, or alternation. For example, it does not explain which entailments are associated with KEY.UND for *spray* vs. *load* vs. *cut*. Furthermore, it fails to explain which entailments are appropriate for different alternations (e.g. affectedness for conative and locative alternations, traversal for preposition drop alternations, etc.). The specificity condition on KEY.UND thus needs to be indexed to both the verb and alternation. Second, this approach fails to capture non-undergoer alternations. In the dative alternation the alternating participant is not necessarily linked to UND (Kordoni 2004 posits an additional macrorole) and in the reciprocal alternation in (6) there is not necessarily an UND attribute at all. Thus more KEY-based conditions must be stipulated for other attributes that mirror the one posited for UND. Third, this analysis involves considerable polysemy, something that is undesirable if it can be avoided, especially since the different variants in each alternation appear to share a considerable amount of invariant semantics despite the contrasts.

Although a key motivation for Davis and Koenig’s analysis is the elimination of unnecessary semantic constructs, their approach still relies on a mediating level of structure between entailments and argument structure. While none of the problems

³See Kordoni (2002) for related HPSG work on Greek, Davis (2001:135-140) for a non-MRS version of the same analysis, and Van Valin (2002) for a similar approach in Role and Reference Grammar. Note that *use-rel* and *spray-ch-of-state-rel*, present in the *spray_{with}* variant, are absent from the *spray_{loc}* variant, although these presumably are invariant across both uses of *spray* and should be present in both AVMs.

discussed here are insurmountable, they suggest that this level of structure does not provide the most natural way to capture the contrasts discussed above. Instead, we want to be able to state constraints directly on the lexical entailments.⁴ Once we allow this, it may then even be possible to eliminate the intermediate semantic structure. I outline such a theory in the next section.⁵

3 A Purely Entailment Based Approach

I encode (13) in terms of a theory of thematic roles as sets of entailments as in Dowty (1989, 1991). I define first an **individual thematic role** (following the terminology of Dowty 1989:76), which is the set of entailments that constitutes the role a verb assigns to one of its participants:

- (15) For verb V describing situation s , the role participant x plays in s is a set of V -specific entailments R , which is x 's **individual thematic role**.

Thus the individual thematic role R of some participant x is the set of all things, from the very general to the quite specific, that V says about x 's role in s . Such thematic roles are quite rich in information. Two such roles are illustrated in (16) for the locatum participants of *load* and *spray* respectively.

(16)

	V-Specific	More General	Most General
LOCATUM _{load}	{ x loaded onto sth, ..., }	x is moved, ..., }	x is affected, ..., }
LOCATUM _{spray}	{ x sprayed out of sth, ..., }	x is moved, ..., }	x is affected, ..., }

At a very verb-specific level, these two locatum participants have idiosyncratic semantics associated with them that make them unique from one another, e.g. the locatum of *load* is loaded onto something while the locatum of *spray* is sprayed out of something onto something else. At a more general level, each of these participants is moved somewhere, an entailment that they share in common, and in fact the two more specific entailments of being moved onto or out of something imply this. Still more generally, we can say that in some way each participant is therefore affected somehow, i.e. changes its condition (in this case its position), an entailment again both share in common and one that is again implied by the more specific entailments. Thus individual thematic roles have two properties relevant here: (a) they contain very verb-specific entailments that differentiate them but also share quite a lot of more general entailments, and (b) the entailments within each role are at least partly structured in terms of implicational relationships.

Some (though not all) individual thematic roles can be related to one another in terms of what I refer to as **specificity**:

⁴Even if one replaces UND with attributes directly representing the characteristic entailments (as in Koenig and Davis 2003, e.g. positing an INCREMENTAL-THEME feature), this approach still fails to capture the variable behavior of the same alternation with different verbs.

⁵See Beavers (to appear b) for further discussion of why predicate decompositions as in Levin and Rappaport (Hovav) (1988, 1998), Pinker (1989), Jackendoff (1990), Davis (2001), *inter alia* are ill-suited to capture (13). See Koenig and Davis (2004) for a general critique of such approaches.

(17) For individual thematic roles R and Q , R is more **specific** than Q if $Q \subset R$.

Role R is more specific than Q if R contains all the entailments of Q plus at least one more. Not all individual thematic roles stand in a specificity relationship (e.g. the two locatum roles in (16) do not), but once we define thematic roles as sets of entailments it is possible that some roles will stand in specificity relationships to one another. On the basis of (17), we can reformulate (13) as in (18).

(18) **Morphosyntactic Alignment Principle (MAP):** When participant x may be realized as either a direct or oblique argument of verb V , it bears role R as a direct argument and role Q as an oblique where $Q \subset R$.

Thus we now have a more explicit framework for capturing the underspecificity contrasts exhibited by argument/oblique alternations. However, this reformulation does not predict *which* roles x will bear for a given alternation and verb V . To make predictions about this we need a more limited and general notion of possible contrasts to which we can tie the MAP. Following Dowty (1989), I assume that broad argument-marking patterns such as argument/oblique contrasts are based on a more general kind of role called a **thematic role type** (where the term “type” here is not related to the HPSG notion of “type”):

(19) A **thematic role type** is a set of entailments shared across individual thematic roles.

A thematic role type is an intersection of individual thematic roles that serves to cross-classify individual thematic roles by means of shared entailments. Of course, there are numerous thematic role types (any intersection of any individual thematic roles is a thematic role type). As Dowty (1989) argues, only some thematic role types are linguistically interesting for describing generalizations about argument realization. The set of linguistically relevant thematic role types Dowty refers to as **L-thematic roles**. Exactly which thematic role types are L-thematic roles is not a question I intended to address here, but presumably these are very general thematic role types involving general entailments having to do with causation, affectedness, possession, etc., at the level of generality of the most general entailments in (16). For object alternations such as the locative alternation I propose the following L-thematic roles are relevant for capturing the appropriate generalizations, based only on a very general notion of “affectedness” that subsumes being changed, moved, created, destroyed, searched, or covered, i.e. different ways something can be dynamically acted upon (Beavers to appear b).

(20)	L-Thematic Roles	Informal Definition	Example Individual Thematic Roles
	TOTALLY AFFECTED	Affected to a specific degree	Completely loaded or moved entity (DO_{load})
	AFFECTED	Affected to a non-specific degree	Loaded, moved entity ($oblique_{load}$), or cut entity (DO_{cut})
	PARTICIPANT	Unspecified for affectedness	Entity not known to be affected ($oblique_{cut}$)

Something is **TOTALLY AFFECTED** if its individual thematic role includes entailments involving being affected (e.g. moved or changed) to some particular degree (e.g. “holistically”) such as the roles of the location and locatum direct objects in (1). Something is **AFFECTED** if its individual thematic role contains entailments involving being changed, moved, created, etc., though not necessarily to a specific degree, as for instance the direct object of *cut* (which may be a little or a lot cut in the course of a cutting event). Finally, something is a **PARTICIPANT** if no particular affectedness is known at all, such as the oblique arguments of *cut* above.⁶ The exact form of these L-thematic roles is not relevant here, although we could assume for now that they can be defined as in (22) in terms of two general entailments that form an implicational relationship as in (21).

(21) $\forall d.x \text{ is affected to } d \text{ degree} \Rightarrow \exists d.x \text{ is affected to } d \text{ degree}$

(22) $\left\{ \begin{array}{l} \text{TOTALLY AFFECTED} \\ \forall d.x \text{ is affected to } d \text{ degree} \\ \exists d.x \text{ is affected to } d \text{ degree} \end{array} \right\} \supset \left\{ \begin{array}{l} \text{AFFECTED} \\ \exists d.x \text{ is affected to } d \text{ degree} \end{array} \right\} \supset \left\{ \begin{array}{l} \text{PARTICIPANT} \\ \{ \} \end{array} \right\}$

TOTALLY AFFECTED and **AFFECTED** share the entailment that there exist some degree to which the participant is affected, and **TOTALLY AFFECTED** additionally carries an entailment that the degree of affectedness is unique. **PARTICIPANT** is the empty role. Just like individual thematic roles, thematic role types also form specificity hierarchies as demonstrated by the subset relations in (22). The alternations of individual thematic roles in (1) and (4) (and other alternations) can thus be described as **minimal specificity contrasts in thematic role types** along (22):⁷

(23)

General Contrast	:	TOTALLY AFFECTED		AFFECTED		PARTICIPANT
<i>load/spray</i>	:	DO	→	OBL		
<i>cut/break</i>	:			DO	→	OBL

In essence this represents a kind of relativized harmonic alignment of thematic roles to markedness, where the hierarchy in (22) represents a natural prominence hierarchy of thematic role types based on specificity/implication, and realization options are aligned along this hierarchy in terms of their relative markedness, where the less marked options (direct argument realizations) are aligned to the most prominent L-thematic role in the hierarchy and the more marked options (oblique realizations) align to the next most specific role (see Aissen 2003 on Silverstein 1976-style animacy and definiteness hierarchies in differential object marking; see Fillmore 1977 for more general discussion of prominence scales in argument realization). The notion of minimal specificity contrasts in L-thematic roles can be characterized set-theoretically via a function *min* from individual thematic roles to individual thematic roles as in (24), by which we can reformulate (18) as in (25).

⁶All of these concepts can be defined more precisely in the scalar approach to dynamic predicates in Beavers (to appear a). (cf. Hay et al. 1999) in terms of constraints dynamic predicates do or do not place on the scales that measure out the temporal structure of the event. In Hay et al. (1999) terms, total affectedness corresponds to quantized change and affectedness to non-quantized change.

⁷Presumably the most specific L-thematic role corresponds to Dowty’s (1991) proto-patient role as proposed in Beavers (to appear b), though I do not discuss this further here.

- (24) For L-thematic roles τ_1 and τ_2 , $\tau_1 \supset \tau_2$, forming a minimal specificity contrast, and for individual thematic role R of type τ_1 , the role $Q = \text{min}(R)$ is the maximal subset of R of type τ_2 .
- (25) **MAP (Revised):** When participant x may be realized as either a direct or oblique argument of verb V , it bears role R as a direct argument and role $\text{min}(R)$ as an oblique.

For example, *the wagon* as a direct object in (1) has individual thematic role of type **TOTALLY AFFECTED** but an individual thematic role of type **AFFECTED** as an oblique, which contains all of the same entailments except those that would make its thematic role type **TOTALLY AFFECTED**. This is outlined in (26).

- (26) a. loaded the wagon with the hay b. loaded the hay onto the wagon
- | | |
|--|--|
| $\left\{ \begin{array}{l} \mathbf{\text{all of } x \text{ is all filled up}} \\ \mathbf{\exists d.x \text{ is affected to } d \text{ degree}} \\ \dots \\ x \text{ is loaded} \\ \exists d.x \text{ is affected to } d \text{ degree} \\ \dots \\ x \text{ is a locational goal} \end{array} \right\}$ | $\left\{ \begin{array}{l} x \text{ is loaded} \\ \exists d.x \text{ is affected to } d \text{ degree} \\ \dots \\ x \text{ is a locational goal} \end{array} \right\}$ |
|--|--|

In (26a) the role assigned to the location participant involves numerous entailments of varying generality. This role has thematic role type **TOTALLY AFFECTED** since it contains all of the entailments of that role. The ones in boldface are those that are unique to the **TOTALLY AFFECTED** role or else imply the entailments that are unique to it. In the corresponding role in (26b) the only remaining entailments are those that are not unique to the **TOTALLY AFFECTED** type or do not imply such entailments, i.e. the boldfaced ones from (26a). What is left are entailments that include being affected to a non-specific degree and invariant entailments not part of the relevant L-thematic roles (e.g. being a location). This individual thematic role is of type **AFFECTED** but not type **TOTALLY AFFECTED** since it lacks the crucial entailment of being affected to a specific degree. Thus the individual thematic role contrast in (26) is keyed to L-thematic roles in a way that generates a cascade effect: verb-specific entailments that imply the more general ones (due to the implicational relationships between entailments) are also underspecified. In this manner, verb, verb class, and alternation specific contrasts are intrinsically captured since contrasts at one level of generality force contrasts at others.

4 Encoding in HPSG

I encode (25) as constraints on $v\text{-}lxm$, which I present in two parts: the constraints on linking direct arguments, and those for linking obliques. I first assume a feature **ROLES** in each verb's **CONT** value (assuming the MRS semantics of Copestake et al. 2003 but ignoring scoping-related features here):

$$(27) \text{ roles-mrs} \Rightarrow \text{mrs} \ \& \ \left[\text{ROLES} \langle \text{set}(\text{entailments}) \rangle \right]$$

The type *roles-mrs* is the type of the CONT(ENT) value of verb lexemes (and, as we will see below, preposition lexemes), and the ROLES feature defines the list of roles a head assigns to its *direct* arguments. Role assignment is done via EPs of type *role-rel* on the head's RELS list:

$$(28) \quad \textit{role-rel} \Rightarrow \textit{elementary-predication} \ \& \ \left[\begin{array}{l} \text{ARG1 } i \\ \text{ROLE } \textit{set}(\textit{entailments}(i)) \end{array} \right]$$

Assigning roles to the direct arguments of verbs is done by associating each NP argument directly with a role on the verb's ROLES list:⁸

$$(29) \quad \textit{Direct argument linking: } v\text{-}lxm \Rightarrow \left[\begin{array}{l} \text{ARG-ST } \langle \text{NP}_{i_1}, \dots, \text{NP}_{i_n} \rangle \circ \textit{list}(\textit{non-NP}) \\ \text{CONT } \left[\begin{array}{l} \text{ROLES } \langle \boxed{R_1}, \dots, \boxed{R_n} \rangle \circ \textit{list} \\ \text{RELS } \left\langle \left[\begin{array}{l} \textit{role-rel} \\ \text{ARG1 } i_1 \\ \text{ROLE } \boxed{R_1} \end{array} \right], \dots, \left[\begin{array}{l} \textit{role-rel} \\ \text{ARG1 } i_n \\ \text{ROLE } \boxed{R_n} \end{array} \right] \right\rangle \circ \textit{list} \end{array} \right]$$

Thus, each NP argument of any verb (but not non-NP arguments) is assigned some role from the verb's ROLES list, although not every role is necessarily assigned to some NP argument. Assigning roles to PP arguments of the verb is more complicated. As discussed in the previous section, ideally the role assigned to any PP argument is the output of *min* for some unassigned role on the ROLES list, i.e. a role that is minimally contrastive in terms of L-thematic roles to the role that a corresponding direct argument could be assigned.⁹

$$(30) \quad \textit{Oblique linking (preliminary): } v\text{-}lxm \Rightarrow \left[\begin{array}{l} \text{ARG-ST } \langle \text{PP}_{j_1}, \dots, \text{PP}_{j_m} \rangle \circ \textit{list}(\textit{non-PP}) \\ \text{CONT } \left[\begin{array}{l} \text{ROLES } \langle \boxed{Q_1}, \dots, \boxed{Q_m} \rangle \circ \textit{list} \\ \text{RELS } \left\langle \left[\begin{array}{l} \textit{role-rel} \\ \text{ARG1 } j_1 \\ \text{ROLE } \textit{min}(\boxed{Q_1}) \end{array} \right], \dots, \left[\begin{array}{l} \textit{role-rel} \\ \text{ARG1 } j_m \\ \text{ROLE } \textit{min}(\boxed{Q_m}) \end{array} \right] \right\rangle \circ \textit{list} \end{array} \right]$$

However, in addition to assuming that each oblique argument receives a minimally contrastive role, we also want to restrict which oblique markers occur for which arguments, i.e. be sure that not any PP can receive any role. To constrain

⁸For the remainder of the paper I ignore irrelevant features such as SS and LOC in the paths to the features of interest. The constraints I propose here are English specific. For a language with more elaborate case morphology we would need to distinguish not just between NPs and non-NPs but also between NPs marked with structural case and NPs marked with inherent (oblique) case, presumably in terms of a CASE feature. Note that these constraints are defaults; a particular verb can override the general linking if for instance it idiosyncratically selects a particular oblique marker.

⁹The constraints in (29) and (30) are presented separately only for presentational purposes. These are intended to be read together and the coidentification tags (the \boxed{R} s and \boxed{Q} s) are meant to be unique.

which obliques can bear which roles, I assume that oblique markers are semantically contentful and also have CONT values of type *roles-mrs*, contributing individual thematic roles that must be compatible with the role assigned by the verb, following in particular Gawron (1986) (see also Markantonatou and Sadler 1995, Wechsler 1995, and Davis 2001; see Pesetsky 1995:133 on “mediated θ -selection”). For example, the PPs relevant for (1) are given in (31), where the individual thematic roles supplied by each preposition represent their inherent semantics.

$$(31) \quad \text{a.} \quad \left[\begin{array}{l} \text{ORTH} \langle \textit{onto, the, wagon} \rangle \\ \text{CONT} \left[\begin{array}{l} \text{ROLES} \langle \text{LOCATION}_{\textit{goal}} \rangle \\ \text{RELS} \langle [\textit{wagon-rel}], \dots \rangle \\ \text{ARG1 } i \end{array} \right] \end{array} \right] \quad \text{b.} \quad \left[\begin{array}{l} \text{ORTH} \langle \textit{with, the, hay} \rangle \\ \text{CONT} \left[\begin{array}{l} \text{ROLES} \langle \text{CAUSALLY-INTERM.} \rangle \\ \text{RELS} \langle [\textit{hay-rel}], \dots \rangle \\ \text{ARG1 } i \end{array} \right] \end{array} \right]$$

In each case the individual thematic role is rather general in nature, just specifying some basic conditions that its complement must satisfy. The role $\text{LOCATION}_{\textit{goal}}$ simply defines a participant as a locational goal, i.e. a location of some sort (potentially abstract) to which some participant arrives.¹⁰ Following Croft (1991:178), *with* assigns a role CAUSALLY-INTERMEDIATE, i.e. an entity that is intermediate in the event’s force-dynamic structure, as illustrated in the (simplified) Croft-style force-dynamic diagram in (32).

$$(32) \quad \begin{array}{ccccccc} \textit{John} & & \textit{hay} & & \textit{wagon} & & \text{(Participants)} \\ \bullet & \longrightarrow & \bullet & \longrightarrow & \bullet & & \text{(Force dynamic chain)} \end{array}$$

In other words, in a loading event John acts forcibly on the hay, and then this force is transmitted to the wagon, which becomes loaded with the hay. This very general thematic role in fact covers both the instrumental and locatum uses of *with* (cf. Levin and Rappaport 1988 on *with* as a “displaced theme” marker). To ensure compatibility between the individual thematic role licensed by the verb and the individual thematic role licensed by the preposition, I assume that the latter must be a superset of the former (similar to Gawron’s assumption that oblique arguments contribute semantics already determined by the verb):

$$(33) \quad \begin{array}{ccccc} \text{Role}_{\textit{Prep}} & & \text{Actual Role} & & \text{Role}_V \\ P & \subseteq & \textit{min}(Q) & \subset & Q \end{array}$$

That is, the actual role of the participant is a superset of what is contributed by the preposition but is a subset of what is contributed by the verb (determined by a minimal L-thematic role contrast as above). I encode this superset relation via a function *sup*, where $\textit{sup}(P, Q) = Q$ if $P \subseteq Q$ and \perp if $P \not\subseteq Q$, updating the constraints in (30) to incorporate this:¹¹

¹⁰I assume that specific choices of prepositions, e.g. *on(to)*, *in(to)*, are pragmatically determined and not part of the thematic role per se.

¹¹This function is only for presentational convenience, serving to co-identify each entailment in the preposition role with something in the verb role. Spelling this out explicitly reduces AVM readability.

(34) Oblique linking (final): $v-lxm \Rightarrow$

$$\left[\begin{array}{l} \text{ARG-ST} \left\langle \text{PP}_{j_1} \left[\text{ROLES} \left\{ \boxed{P_1} \right\} \right], \dots, \text{PP}_{j_m} \left[\text{ROLES} \left\{ \boxed{P_m} \right\} \right] \right\rangle \circ \text{list}(\text{non-PP}) \\ \text{CONT} \left[\begin{array}{l} \text{ROLES} \left\langle \boxed{Q_1}, \dots, \boxed{Q_m} \right\rangle \circ \text{list} \\ \text{RELS} \left\langle \left[\begin{array}{l} \text{role-rel} \\ \text{ARG1 } j_1 \\ \text{ROLE } \min(\text{sup}(\boxed{P_1}, \boxed{Q_1})) \end{array} \right], \dots, \left[\begin{array}{l} \text{role-rel} \\ \text{ARG1 } j_m \\ \text{ROLE } \min(\text{sup}(\boxed{P_m}, \boxed{Q_m})) \end{array} \right] \right\rangle \circ \text{list} \end{array} \right] \end{array} \right]$$

The constraints in (29) and (34) determine the MAP in (18). In the next section I discuss how alternations are licensed based on this.

5 Generating Alternations

An alternation is licensed when a verb V licenses a role R for a participant x and there also exists an oblique marker P which inherently bears a role Q such that $Q \subseteq R$. Thus x may be realized either as a direct argument (getting its role directly from V) or as an oblique marked by P , getting its role based on the roles licensed by V and P . The constraints on $v-lxm$ and a language's lexical inventory determine (a) when there is an alternation and (b) what the semantics is. For (1), all that needs to be specified for *load* is a list of roles for direct arguments and an ARG-ST (which may ultimately be derivable from the roles; see §7). No explicit linking needs to be stated (though I stipulate subject linking since I am primarily concerned with objects in this paper):

$$(35) \left[\begin{array}{l} \text{ORTH} \langle \textit{load} \rangle \\ \text{ARG-ST} \langle \text{NP}_i, \text{NP}, \text{PP} \rangle \\ \text{CONT} \left[\begin{array}{l} \text{ROLES} \langle \boxed{\text{L}}\text{LOADER}, \text{LOCATUM}_{\textit{load}}, \text{LOCATION}_{\textit{load}} \rangle \\ \text{RELS} \left\langle \left[\begin{array}{l} \text{role-rel} \\ \text{ARG1 } i \\ \text{ROLE } \boxed{\text{L}} \end{array} \right], \dots \right\rangle \end{array} \right] \end{array} \right]$$

Thus *load* is subcategorized for two NP arguments and one PP argument and licenses three thematic roles: a LOADER, a totally affected LOCATUM (specific to *load*) and a totally affected LOCATION (also specific to *load*). The linking of the roles to ARG-ST (or the form of the prepositions) is not stipulated directly in the lexical entry. This allows one role to be linked to the remaining NP argument and the other to be linked to the PP but with an underspecified role. The preposition inventory of English restricts the possible manifestations of this lexeme in a *head-complement* structure to only two kinds:

- (36)
$$\left[\begin{array}{l} \text{ORTH} \langle \text{loaded, the wagon, with the hay} \rangle \\ \text{DTRS} \langle \text{V, NP}_j, \text{PP}_k \left[\text{ROLES} \left\{ \boxed{1} \text{CAUSALLY-INTERMEDIATE} \right\} \right] \rangle \\ \text{CONT} \left[\begin{array}{l} \text{ROLES} \langle \dots, \boxed{2} \text{LOCATUM}_{load}, \boxed{3} \text{LOCATION}_{load} \rangle \\ \text{RELS} \langle \dots, \left[\begin{array}{l} \text{role-rel} \\ \text{ARG1 } j \\ \text{ROLE } \boxed{3} \end{array} \right], \left[\begin{array}{l} \text{role-rel} \\ \text{ARG1 } k \\ \text{ROLE } \text{min}(\text{sup}(\boxed{1}, \boxed{2})) \end{array} \right], \dots \rangle \end{array} \right] \end{array} \right]$$
- (37)
$$\left[\begin{array}{l} \text{ORTH} \langle \text{loaded, the hay, onto the wagon} \rangle \\ \text{DTRS} \langle \text{V, NP}_j, \text{PP}_k \left[\text{ROLES} \left\{ \boxed{1} \text{LOCATION}_{goal} \right\} \right] \rangle \\ \text{CONT} \left[\begin{array}{l} \text{ROLES} \langle \dots, \boxed{2} \text{LOCATUM}_{load}, \boxed{3} \text{LOCATION}_{load} \rangle \\ \text{RELS} \langle \dots, \left[\begin{array}{l} \text{role-rel} \\ \text{ARG1 } j \\ \text{ROLE } \boxed{2} \end{array} \right], \left[\begin{array}{l} \text{role-rel} \\ \text{ARG1 } k \\ \text{ROLE } \text{min}(\text{sup}(\boxed{1}, \boxed{3})) \end{array} \right], \dots \rangle \end{array} \right] \end{array} \right]$$

Acceptable structures similar to (37) are licensed by other locational goal markers (e.g. *in(to)*), but otherwise no other preposition (e.g. *about* or *with*) satisfies the criterion that the oblique marker role be a subset of the verb role. Likewise, presumably *with* is the only CAUSALLY-INTERMEDIATE marker in English (*by*, *via*, etc. mark more specific means/manner roles not subsets of LOCATUM_{load}). Any other oblique markers, or different linking with the same ones, would lead to a unification failure.¹² Furthermore, no verbal polysemy is required to license the alternation, which arises from the underspecified linking.¹³

Since the lexical and morphosyntactic inventory of argument realization devices determines the shape of alternations this approach also makes predictions about which alternations will or will not occur in a given language. For example, French and Spanish both appear to lack a dative alternation of the form in (5). However, both languages also generally lack any type of general allative marker comparable to English *to* for marking goals of motion that could alternate with dative *a* (Talmy 2000). Conversely, Finnish exemplifies the other alternative: all goal/recipient participants are marked in the allative case and there is no alternation, reflecting the general lack of a dative case or double object constructions in Finnish (Karlsson 1999). Thus the lack of alternations is correlated with the general lack of certain types of realization devices. A slightly more subtle example of such a correlation can be found with Japanese verbs of removal. In English, verbs of removal, like locative alternating verbs, allow either the location or the locatum to be realized as the direct object:

¹²For the first object position of double-object verbs, which has no (overt) oblique marker in English but bears possessional semantics (as discussed in §1), the oblique-like semantics could be defined as special type of ARG-ST with three NP arguments, the middle one being restricted to possessors, or else in terms of a special double object construction.

¹³See also Markantonatou and Sadler (1995), who likewise assume underspecified verbs but with a complex semantics involving reified proto-roles *causer/patient* similar to ACT/UND above.

- (38) a. John cleared the dishes from the table.
 b. John cleared the table of the dishes.

In (38a), where the locatum is the direct object, the location is marked by the source marker *from*. In (38b) the location is realized as direct object but the locatum is marked by *of*, which is historically an erstwhile ablative (<Old English *æf*, related to *off* according to the OED) and has various functions marking separation/source semantics (e.g. *Little (be)came of it*, *We desired it of him*, *She died of disease*, *He partook of the salad*). Due to its function as both a locatum (akin to an instrument) and ablative marker, Hook (1983) refers to *of* as an “abstrument” marker. In Japanese, removal verbs also alternate (cf. Kageyama 1980:38, (10)):

- (39) a. *Ueetaa-wa syokutaku-kara syokki-o katazuketa.*
 waiter-TOP table-from dishes-ACC cleared.
 ‘The waiter cleared the dishes from the table.’
 b. *Ueetaa-wa syokutaku-o (*syokki-de/kara) katazuketa.*
 waiter-TOP table-ACC (*dishes-INST/from) cleared.
 ‘The waiter cleared the table (of the dishes).’

In (39a) the locatum is the direct object and the location is marked by *-kara* ‘from’. But in (39), when the location is direct object, there is no grammatical way to realize the locatum as an oblique. This correlates, however, with a general lack of an abstrument marker in Japanese with the functionality of the English *of*. Thus these data reflect a general correspondence of the shape of the lexicon and the possibilities of alternations: if no marker independently realizes a role compatible with a certain verb’s, then furthermore there should be no alternation with that verb.

One potential problem for this analysis is so-called “default” prepositions that mark arguments when for some reason the governing head is unable to assign case (Chomsky 1981). If such prepositions exist they presumably are semantically vacuous (serving only a grammatical role), which would mean licensing an empty role on the approach outlined here. However, an empty role is a subset of any role assigned by any verb, and thus any direct argument should alternate with the default preposition.¹⁴ Clearly this is not the case. So what, then, do we say about default prepositions? I again appeal to a lexical solution by suggesting that “default” prepositions simply do not exist, at least not in the verbal domain.

The most common candidate for a default preposition is English *of* since it occurs universally as a complement marker for nouns (e.g. *the destruction of the city/the Romans*; Chomsky 1970), adjectives (e.g. *fond of Mary*), and sometimes prepositions (e.g. *off of the rock*). Similar prepositions occur in other languages (e.g. Japanese *-no* likewise marks nearly all arguments of nouns; Martin 1975). However, as far as I am aware, most uses of *of* in the verbal domain are in its abstrument/source use, with some uses also as a material/topic role (e.g. *wrote of him*,

¹⁴I would like to thank an anonymous reviewer for pointing out this possibility to me.

notified of the plans) or as a comparative (e.g. *it tastes of mutton*). Thus while *of* is perhaps a few ways polysemous, it is not clear that it is semantically vacuous. As much as it is a default preposition in non-verbal domains it is in some sense a direct argument marker and thus should not be subject to constraints on obliques parallel to those in (34). A second candidate for “default” status is the agentive *by* that occurs with verbs in the passive voice marking demoted subjects. It is well known that virtually any subject of any active transitive verb in English can be marked by *by* in the passive (Fillmore 1968), suggesting that *by* carries no inherent semantics except as a general proto-agent marker. If this is the case then the theory outlined here would predict that we should see nominative/*by* alternations in the active voice, e.g. *John saw Mary* and *By John saw Mary*. This I suggest is ruled out by independent constraints on argument structure. Nearly every grammatical theory has some version of the GB Extended Projection Principle (EPP) (Chomsky 1981), such as the Final-1 Law in Relational Grammar (Perlmutter and Postal 1983), the Subject Condition in LFG’s Lexical Mapping Theory (Bresnan and Kanerva 1989), and constraints in HPSG that the first element of a verb’s ARG-ST be an NP (Ginzburg and Sag 2000). As much as it is true that languages tend to resist non-NP subjects (except CPs) then what rules out a *by* alternation are constraints on argument structure preventing oblique first arguments (except where lexically specified by the verb, i.e. dative subjects in Russian or Icelandic). Thus there does not appear to be any evidence of a truly default preposition in English for verbal argument marking, and I am not aware of any such evidence in any other languages.

6 Comparison to Ackerman and Moore

The approach proposed here bears some similarity to Ackerman and Moore’s (2001) approach to oblique realization, and a discussion of the differences is certainly in order. Ackerman and Moore (2001) propose that direct arguments are “more prototypical” than obliques relative to Dowty’s proto-roles according to their PARADIGMATIC ARGUMENT SELECTION PRINCIPLE (*ibid.*:169, (2)):

- (40) PARADIGMATIC ARGUMENT SELECTION PRINCIPLE:
 Let $P(\dots, arg_i, \dots)$ and $P'(\dots, arg'_i, \dots)$ be related predicates, where arg_i and arg'_i are corresponding arguments. If arg_i and arg'_i exhibit different grammatical encodings and arg_i is more prototypical with respect to a particular proto-role than arg'_i , then arg_i ’s encoding will be less oblique than arg'_i ’s encoding.

Thus for Ackerman and Moore every alternation reflects a paradigmatic relationship between two verb forms with different thematic role and argument structure assignment. One form takes argument i as a direct argument, the second as an oblique, and the former assigns a “more prototypical” role to i than the latter. However, what Ackerman and Moore mean by “more” prototypical is not specified. The analyses they propose involve the direct argument bearing an additional proto-role entailment not borne by the oblique. However, nothing in their approach indicates (a) which proto-role entailments will vary for a given alternation and (b)

whether or not the less prototypical role contains any non-proto-role entailments not assigned to the more prototypical role, including even the negation of one of the relevant proto-role entailments. On my approach, the contrasts are assumed to follow from a more general notion of possible contrasts and “more prototypical” is given a specific interpretation in terms of underspecificity, making a stronger claim, as well as detailing how these entailments connect to more verb-specific ones.

Furthermore, my approach, though defining thematic roles as sets of entailments, is not wedded to proto-roles and thus captures a broader set of generalizations. For direct objects there is evidence for a proto-patient analysis given the variability in what can be an object, for instance all of the L-thematic roles above are found associated with the object of some verb in English:

- (41) a. John ate the bread. (TOTALLY AFFECTED)
b. John tore the bread. (AFFECTED)
c. John touched the bread. (PARTICIPANT)

The direct object may bear nearly any role provided it is the most like the proto-patient for a given verb, and similarly subjects show a wide range of thematic role variability, suggesting a proto-agent analysis for subjecthood. However, there is no evidence for a corresponding “proto-recipient” role for first objects of ditransitive verbs, since first objects are categorically possessors (or perhaps more generally the subject of some kind of HAVE predicate as in Green 1974). No ditransitive verb selects a first object that does not meet this requirement, i.e. there is no ditransitive taking a goal as a first object. However, the MAP given in (18) nonetheless predicts the semantics of dative alternation as discussed in §1, since it makes claims about the roles assigned to direct arguments vs. obliques regardless of whether a proto-role is involved in the analysis. It is not clear how Ackerman and Moore’s approach explains this, suggesting that the analysis proposed here has broader application.

7 Conclusion

The approach to argument/oblique alternations proposed here has three advantages over previous work. First, it captures the general underspecificity contrasts that govern such alternations and does so in a way that transparently links verb, verb class, and alternation specific generalizations. Individual thematic roles inherently cluster together at different levels of granularity in terms of shared entailments, predicting that verbs will cluster together into classes that behave similarly for certain semantic contrasts. Alternations operate at a very high level of generality (the level of L-thematic roles) and thus large numbers of loosely connected verbs may undergo the “same” alternations keyed to very general semantic criteria but manifest these alternations in different ways. Second, this approach reduces the amount of polysemy needed to capture alternations. Third, the form-to-meaning mapping is encoded without intermediate structure such as predicate decompositions or structured EPs as in Koenig and Davis (2004). This approach does assume

thematic role types, an additional construct needed to develop a general theory of possible contrasts. However, the existence of thematic role types follows naturally from assuming that thematic roles are sets of entailments, since sets of entailments may inherently share members (though as noted above only certain thematic role types, the L-thematic roles, are relevant for linguistic generalizations). The additional semantic constructs posited by predicate decomposition theories, however, involve a type of structure that does not fall organically out of the entailments verbs associate with their arguments.

However, this analysis is by no means complete; I have ignored several issues here. First of all, there is the question of how subject and object linking happen more generally, and for this we presumably still need a proto-role theory as in Dowty (1991). In this sense the approach outlined here represents a step towards bringing obliques into the theory of Dowty. Second, I have not dealt here with verbs that do not undergo alternations (e.g. *put* and *fill* are English locative verbs that do not alternate). However, these can be analyzed in terms of proto-roles as well, where for a verb like *load* the two participants are equally as proto-patientive, while *put* and *fill* asymmetrically associated more proto-patient entailments with one argument, ensuring that it is always the direct object. For more on these two points see Beavers (to appear b). Third, I have not dealt with non-semantically based alternations, i.e. those that do not mark a difference in interpretation (e.g. *John blamed Jo for his problems/his problems on Jo*). However, it is well known that other factors may govern alternations, such as animacy, referentiality, heaviness, definiteness, etc. (Erteschik-Shir 1979, Wasow 2002, Aissen 2003). Thus the MAP is just one of many harmonic alignment principles, and a more general theory of argument realization must integrate all of these factors (as suggested also by Fillmore 1977 and Davis and Koenig 2000).

Finally, I make no predictions about which argument structures a given verb may have (having assumed e.g. that *load* takes one PP and two NP arguments). However, degrees of affectedness are known to partly govern transitivity cross-linguistically (cf. Hopper and Thompson 1980, Tsunoda 1981, Testelec 1998), and ditransitivity is cross-linguistically correlated with transfer of possession (Croft et al. 2001). Thus some aspects of argument structure, which I assume is partly independent of linking (cf. Davis 2001), may be predictable by the same criteria that govern alternations. How these interact is a matter of future investigation.

References

- Ackerman, Farrell and Moore, John. 2001. *Proto-Properties and Grammatical Encoding: A Correspondence Theory of Argument Selection*. Stanford, CA: CSLI Publications.
- Aissen, Judith. 2003. Differential Object Marking: Iconicity vs. Economy. *Natural Language and Linguistic Theory* (21), 435–483.

- Anderson, Stephen R. 1971. On the Role of Deep Structure in Semantic Interpretation. *Foundations of Language* 7(3), 387–396.
- Beavers, John. To appear a. Scalar Complexity and the Structure of Events. In Johannes Dölling and Tatjana Heyde-Zybatow (eds.), *Event Structures in Linguistic Form and Interpretation*, Berlin: Mouton de Gruyter.
- Beavers, John. To appear b. Thematic role specificity and argument/oblique alternations in English. In *Proceedings of WECOL 2004*, University of Southern California, Los Angeles.
- Bresnan, Joan and Kanerva, Jonni M. 1989. Locative Inversion in Chicheŵa. *Linguistic Inquiry* 20(1), 1–50.
- Chomsky, Noam. 1970. Remarks on Nominalization. In Roderick A. Jacobs and Peter S. Rosenbaum (eds.), *Readings in English Transformational Grammar*, pages 184–221, Waltham, MA: Ginn.
- Chomsky, Noam. 1981. *Lectures on Government and Binding*. Dordrecht: Foris.
- Copestake, Ann, Flickinger, Dan, Sag, Ivan and Pollard, Carl. 2003. Minimal Recursion Semantics: An Introduction, <http://www.cl.cam.ac.uk/~acc10/papers/newmrs.ps>.
- Croft, William. 1991. *Syntactic Categories and Grammatical Relations: The Cognitive Organization of Information*. Chicago: University of Chicago Press.
- Croft, William, Barðdal, Jóhanna, Hollmann, William, Nielsen, Maike, Sotirova, Violeta and Taoka, Chiaki. 2001. Discriminating Verb Meanings: The Case of Transfer Verbs, handout, LAGB Autumn Meeting, Reading.
- Davis, Anthony. 2001. *Linking by Types in the Hierarchical Lexicon*. Stanford, CA: CSLI Publications.
- Davis, Anthony and Koenig, Jean-Pierre. 2000. Linking as constraints on word classes in a hierarchical lexicon. *Language* 76(1), 56–91.
- Dowty, David. 1989. On The Semantic Content of the Notion ‘Thematic Role’. In Gennaro Chierchia, Barbara H. Partee and Raymond Turner (eds.), *Properties, Types, and Meaning*, Dordrecht: Kluwer Academic Publishers.
- Dowty, David. 1991. Thematic Proto-Roles and Argument Selection. *Language* 67(3), 547–619.
- Erteschik-Shir, Nomi. 1979. Discourse Constraints on Dative Movement. In Talmy Givón (ed.), *Discourse and Syntax*, pages 441–468, New York: Academic Press.
- Fillmore, Charles J. 1968. The Case for Case. In Emmon Bach and Robert T. Harms (eds.), *Universals in Linguistic Theory*, New York: Holt.

- Fillmore, Charles J. 1977. The Case for Case Reopened. In Peter Cole and Jerrold M. Sadock (eds.), *Grammatical Relations*, pages 59–82, New York: Academic Press.
- Gawron, Jean Mark. 1986. Situations and Prepositions. *Linguistics and Philosophy* 9, 327–382.
- Ginzburg, Jonathan and Sag, Ivan A. 2000. *Interrogative Investigations: The Form, Meaning, and Use of English Interrogatives*. CSLI Publications.
- Green, Georgia. 1974. *Semantic and Syntactic Regularity*. Bloomington, IN: Indiana University Press.
- Harley, Heidi. 2003. Possession and the Double Object Construction. In Pierre Pica and Johan Rooryck (eds.), *Linguistic Variation Yearbook 2*, pages 31–70, Amsterdam: John Benjamins.
- Hay, Jennifer, Kennedy, Christopher and Levin, Beth. 1999. Scalar Structure Underlies Telicity in Degree Achievements. In *The Proceedings of SALT IX*, pages 127–144.
- Hook, Peter. 1983. The English Abstrument and Rocking Case Relations. In *Proceedings of CLS 19*, pages 183–194.
- Hopper, Paul J. and Thompson, Sandra A. 1980. Transitivity in Grammar and Discourse. *Language* 56(2), 251–299.
- Jackendoff, Ray. 1990. *Semantic Structures*. Cambridge, MA: MIT Press.
- Kageyama, Taro. 1980. The Role of Thematic Relations in the *Spray Paint* Hypallage. *Papers in Japanese Linguistics* 7, 35–64.
- Karlsson, Fred. 1999. *Finnish: An Essential Grammar*. New York: Routledge.
- Koenig, Jean-Pierre and Davis, Anthony. 2003. Semantically Transparent Linking in HPSG. In Stefan Müller (ed.), *Proceedings of the 2003 HPSG Conference*, Stanford, CA: CSLI Publications.
- Koenig, Jean-Pierre and Davis, Anthony. 2004. The KEY to lexical semantic representations, unpublished ms., University at Buffalo, the State University of New York.
- Kordoni, Valia. 2002. Valence Alternations in Greek: an MRS Analysis. In Jong-Bok Kim and Stephen Wechsler (eds.), *Proceedings of the HPSG 2002 Conference*, pages 129–146, Stanford, CA: CSLI Publications.
- Kordoni, Valia. 2004. Between Shifts and Alternations: Ditransitive Constructions. In Stefan Müller (ed.), *Proceedings of the HPSG 2004 Conference*, pages 151–167, Stanford, CA: CSLI Publications.

- Levin, Beth. 1993. *English Verb Classes and Alternations: A Preliminary Investigation*. Chicago: University of Chicago Press.
- Levin, Beth and Rappaport, Malka. 1988. What to do with Θ -Roles. In Wendy Wilkins (ed.), *Thematic Relations*, San Diego, CA: Academic Press.
- Levin, Beth and Rappaport Hovav, Malka. 1998. Morphology and Lexical Semantics. In Andrew Spencer and Arnold Zwicky (eds.), *The Handbook of Morphology*, Oxford, UK: Blackwell.
- Markantonatou, Stella and Sadler, Louisa. 1995. Linking Indirect Arguments and Verb Alternations In English. In Francis Corblin, Danièle Godard and Jean-Marie Marandin (eds.), *Empirical Issues in Formal Syntax and Semantics*, pages 103–125, Berne: Peter Lang.
- Martin, Samuel. 1975. *A Reference Grammar of Japanese*. New Haven: Yale University Press.
- Perlmutter, David M. and Postal, Paul. 1983. Some Proposed Laws of Basic Clause Structure. In David M. Perlmutter (ed.), *Studies in Relational Grammar I*, Chicago, IL: University of Chicago Press.
- Pesetsky, David. 1995. *Zero Syntax: Experiencers and Cascades*. Cambridge, MA: MIT Press.
- Pinker, Stephen. 1989. *Learnability and Cognition*. Cambridge, Mass: MIT Press.
- Silverstein, Michael. 1976. Hierarchy of Features and Ergativity. In R.M.W. Dixon (ed.), *Grammatical Categories in Australian Languages*, pages 112–171, Canberra: Australian Institute of Aboriginal Studies.
- Talmy, Leonard. 2000. *Toward a Cognitive Semantics: Typology and Process in Concept Structuring*. Cambridge, Mass.: MIT Press.
- Testelec, Yakov G. 1998. On Two Parameters of Transitivity. In Leonid Kulikov and Heinz Vater (eds.), *Typology of Verbal Categories*, pages 29–45, Tübingen: Niemeyer.
- Tsunoda, Tasaku. 1981. Split Case-Marking in Verb-Types and Tense/Aspect/Mood. *Linguistics* 19, 389–438.
- Van Valin, Robert D. 2002. The Role and Reference Grammar Analysis of Three-Place Predicates, unpublished ms., The State University of New York at Buffalo.
- Wasow, Thomas. 2002. *Postverbal Behavior*. Stanford, CA: CSLI Publications.
- Wechsler, Stephen. 1995. *The Semantic Basis of Argument Structure*. Stanford, CA: CSLI Publications.