

Selectional Restrictions in HPSG: I'll eat my hat!

Jan-Philipp Soehn

University of Tübingen

Proceedings of the HPSG05 Conference

Department of Informatics, University of Lisbon

Stefan Müller (Editor)

2005

CSLI Publications

<http://csli-publications.stanford.edu/>

Abstract

This contribution is concerned with integrating the phenomenon of selectional restrictions in HPSG. Firstly, the question of treating selectional restrictions purely in the semantic module is tackled, as there are some contextual (or pragmatic) influences, which can repair the ill-formedness of violated selectional restrictions. Secondly, we present existing approaches to selectional restrictions within the framework and, lastly, make our own proposal which describes the subject as part of the semantics-pragmatics interface. In particular, we show how a semantic ontology can be integrated.

1 Introduction

The phenomenon of selectional restrictions, first described by Chomsky (1965, pp. 114ff), is part of almost every introduction to linguistics. A violation of selectional restrictions is the explanation for the oddity of the following examples:¹

- (1) ¹*Kim ate a motor-bike.*
- (2) ¹*There is an apple bathing in the water.*

The verb *eat* requires an *edible* object and the action of *bathing* can be fulfilled only by an *animate* actor. Consider further examples showing that the choice of possible arguments can vary with different verbs.

- (3) *The dog is drowning.; The philodendron is drowning.;* ¹*The bacon dumpling is drowning.*
- (4) *The dog barks.;* ¹*The philodendron barks.;* ¹*The bacon dumpling barks.*

Even though the view about the role of selectional restrictions is rather diversified, there is general agreement about the central point of compatibility between verbs and their arguments.²

Implemented in a natural language processing system, selectional restrictions help with parsing, word-sense disambiguation and the resolving of anaphora. The word *star* in the sentence “*The astrologer married a star*” is ambiguous between “famous person” and “celestial body”. However, the example can be disambiguated because we know that the object of *marry* must be *human*. In the opposite way, the exact meaning of the polysemous verb *shoot* can be disambiguated by the object it takes:

[†]The research to the paper was funded by the *Deutsche Forschungsgemeinschaft*. I am grateful to Stefan Müller, Frank Richter, Christine Römer, Manfred Sailer, the reviewers and the audience of HPSG’05 for insightful comments and discussion and Janah Putnam for help with the challenges of English.

¹A superscript exclamation mark indicates a violation of selectional restrictions.

²Selectional restrictions play a role with adjectives and nouns, too. In this contribution we will confine ourselves with the discussion of verbs.

(5) *He shot the rabbit.* vs. *He shot the picture.*

Selectional restrictions also are responsible for zeugmatic effects:

(6) *Are you getting fit or having one?* (from the television program M*A*S*H)

A characteristic of selectional restrictions is that they are language-specific. This can be illustrated by the verbs *drive* and *ride* and their German counterparts *fahren* and *reiten*. Consider the following data:³

- (7) a1) *Kim drives a truck/car/ ¹motor-bike/
 ¹bike/ ¹horse*
 a2) *Kim rides a ¹truck/ ¹car/motor-bike/
 bike/horse*
 b1) *Ute fährt ein(en) Lastwagen/Auto/
 Motorrad/Fahrrad/ ¹Pferd*
 b2) *Ute reitet ein(en) ¹Lastwagen/ ¹Auto/
 ¹Motorrad/ ¹Fahrrad/Pferd*

Whereas in English *drive* means a locomotion by operating a motorized vehicle having more than three wheels, the German *fahren* is not sensitive to the number of wheels of the vehicle. The English word *ride* denotes a locomotion while sitting on a saddle or seat like on a horse, the German counterpart *reiten* can be said only for riding on the back of an animal. Thus, selectional restrictions are part of language-dependent lexical information.

Does violation of selectional restrictions always result in an ungrammatical utterance? The answer is no. In metonymic, metaphoric or idiomatic utterances, selectional restrictions may be violated:

(8) *She puts the wine on the table, right next to the glasses.*

A metonymy can be found in example (8), for the object of *put* is the container (e. g. a bottle), rather than the substance.

As a *book* is not *edible*, violating the selectional restriction of *devour*, we understand (9) as being metaphoric:

(9) *He devoured the book in one single night.*

Within idioms we can find violations of selectional restrictions, too. As was pointed out by Soehn and Römer (2004), this could be counted as a marker for a non-free reading. Take for example:

(10) *to pour out one's grief to someone*

(11) *juicy/spicy bits of gossip*

³The German examples are a nearly word-by-word translation, therefore they are not glossed.

Firstly, in (10), the object of the verb *to pour out* must be a container, which doesn't hold for *grief*. Secondly, *bits of gossip* cannot be *juicy* or *spicy* in the literal sense, for *gossip* is abstract. Thus, the violation of selectional restrictions allows us to recognize a nonliteral meaning.

Information from selectional restrictions mark sentences as odd only if one has in mind the lexical meaning of the words and a "normal" context of utterance. This means that there is nothing inherently wrong with a sentence such as (1), because the reader only has to imagine a suitable context (e.g. eating chocolate motor-bikes). In addition, there are certain contextual features that render expressions like *ate a motor-bike* perfectly grammatical. These "repairing contexts" (cf. Chomsky, 1965, p. 158 and Androutsopoulos and Dale, 2000, p. 1) neutralize violations of selectional restrictions and the sentence is fully interpretable:

- (12) a) [!]*Kim ate a motor-bike.*
b) *Kim did not eat a motor-bike.*
c) *One cannot eat motor-bikes.*
d) *Kim tries to eat a motor-bike./Kim believes/dreams that she can eat motor-bikes.*
e) *I'll eat my hat if Kim ate a motor-bike.*
f) *Did Kim really eat a motor-bike?*

The repairing contexts are negation (12 b), modals and negation (c), non-factive verbs as *believe*, *try*, etc. whose arguments introduce a state-of-affairs in a possible – not the actual – world (d), conditionals (e) and questions (f).⁴ Thus, a violation of selectional restrictions is highly context sensitive. Therefore, Androutsopoulos and Dale argue that selectional restrictions are a pragmatic phenomenon.

To sum up, we have so far seen that, on the one hand, selectional restrictions are part of the lexical information. On the other hand, a violation of selectional restrictions does not mean that the expression becomes totally uninterpretable, but some context features may repair the violation or a suitable context-of-utterance even renders the expression perfectly inconspicuous. In our view, one can account for these facts best when regarding the phenomenon of selectional restrictions as part of the semantics-pragmatics-interface.

2 Selectional Restrictions in HPSG

2.1 Previous Approaches

There are not many publications about selectional restrictions in HPSG. We only know about those of Nerbonne (1996) and Androutsopoulos and Dale (2000).

⁴Chomsky (1965, p. 158) also mentions meta-linguistic expressions like *It is not a good idea to eat motor-bikes*.

In his article, Nerbonne focuses on topics which are related to the processing of semantic information. In order to disambiguate the sense of *chair* in the example “*The chair decided on Mary*” he introduces a new feature M-AGT for “mental agent” within the semantics module. Thus one can distinguish between the two meanings “piece of furniture” and “head of organization”. However, the author does not make clear what other features would be necessary and a worked-out concept of selectional or sortal constraints is far beyond the focus of Nerbonne’s contribution.

A more concrete proposal for handling selectional restrictions is described by Androutsopoulos and Dale (op. cit.). The authors describe two alternative approaches. In their first proposal Androutsopoulos and Dale adopt a pragmatic point of view, putting all relevant information about a verb’s selectional restrictions on the BACKGROUND set of the verb. They argue that selectional restrictions belong to the non-literal information, which is always situated in CONTEXT BACKGROUND, in contrast to literal information, which is to be handled in the CONTENT. For this approach the authors need an inferencing component which compares the relevant signs to rule out signs corresponding to readings that violate a selectional restriction. This “constraint-satisfaction reasoning” would have to be pipe-lined after the parser of a natural language processor, because the information comes from a semantic hierarchy and has to be compared with the arguments present.

In their alternative approach, Androutsopoulos and Dale treat selectional restrictions exclusively within CONTENT. They introduce a sortal hierarchy below *index*. The INDEX value of the object of *eat* can thus be constrained to be of sort *edible*. This approach is more efficient for NLP applications (cf. Müller and Kasper (2000) for an analogous account within Verbmobil). However, it yields an immediate failure of analysis when there is a violation of selectional restrictions and so does Nerbonne’s proposal. Neither approach takes into account the effect of a repairing context. In a similar vein, Ben-Avi and Francez (2004) propose to combine information from a semantic ontology with a type-logical grammar. Unfortunately, their analysis within the framework of Categorical Grammar does not take into account repairing contexts either.

2.2 Our Proposal

As we have argued above, the phenomenon of selectional restrictions can be best accounted for by regarding it as part of the semantics-pragmatics-interface. The idea is to put the relevant information into the BACKGROUND set (BGR) of the CONTEXT of a sign and use structure-sharing with respective semantic indices. Contrary to the first proposal by Androutsopoulos and Dale (op. cit.) we introduce a semantic hierarchy with new sorts and relations as part of every *unembedded-sign*. Thus, we avoid the need for a separate inferencing component.

Unembedded signs are potential stand-alone utterances. According to Richter (2004, ch. 2.1.2), they are empirical objects and central to linguistic research. Richter argues already in (1997, ch. 5.2) that a more fine-grained distinction of

signs is necessary. In the signature which he develops, every subsort of *sign* can occur as an embedded and as an unembedded version. Major differences between embedded and unembedded signs are that the latter do not contain any unbound traces (if one assumes that traces exist) and that they have illocutionary force.

As a first step, we define two new elements to figure on the BGR set. These are, following standard assumptions, subsorts of *psoa*.

$$\left[\begin{array}{l} \textit{sel-restr-imp} \\ \text{ARG} \quad \textit{index} \\ \text{MUST-SATISFY} \textit{ selection-sort} \end{array} \right] \left[\begin{array}{l} \textit{sel-restr-stf} \\ \text{ARG} \quad \textit{index} \\ \text{SATISFIES} \textit{ selection-sort} \end{array} \right]$$

The first *psoa* can be introduced to BGR by signs which impose a selectional restriction.⁵ A verb, e. g. *eat*, can subcategorize for a noun with a certain restriction. Nouns such as *apple* satisfy this restriction.⁶ They have also included this information in their BGR set.

The phrase „... *eats apples*“ is sketched in Fig. 1. The collection of all elements in all BGR sets is guaranteed by the CONTEXTUAL-CONSISTENCY-PRINCIPLE (Pollard and Sag, 1994, p. 333), which exists independently of our proposal.

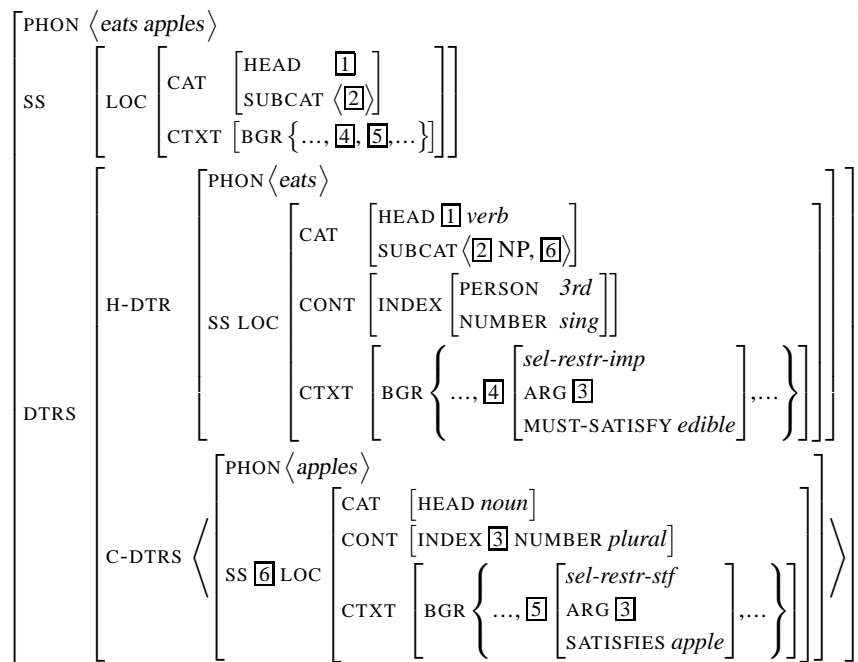

Figure 1: Phrase including selectional restrictions

As a second step we introduce a principle which ensures that the values of MUST-SATISFY (M-STF) and SATISFIES (STF) in the CTXT BGR set are compatible. To be compatible means that the STF value of the argument of *eat* is either identical

⁵*sel-restr-imp* for imposed

⁶*sel-restr-stf* for satisfies

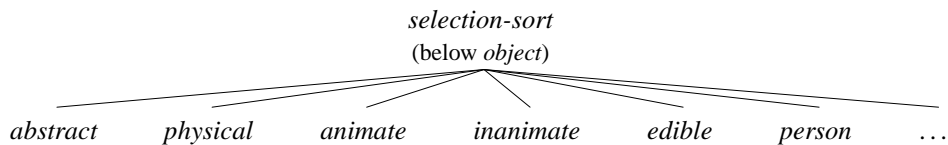

Figure 2: The sort *selection-sort*

to the M-STF value of the verb itself, or that the STF value is a sub-element of the M-STF value in a semantic ontology. In other terms, the verb only requires an edible object, whereas the object itself can be more concrete – a pancake or a banana.

The principle should license only phrases which have compatible values of M-STF and STF – but only if the argument or the whole proposition is outside the scope of a negational, a conditional or a question-operator. As stated above, these contexts “repair” the effect of a violation of selectional restrictions.

(13) VALIDITY-PRINCIPLE OF SELECTIONAL RESTRICTIONS (VPSR, preliminary version):

If in a phrase x there is a sign s , a verb v (s is an argument of v) and a proposition p , which is formed by v and its arguments, and
if neither the meaning associated with s nor the meaning associated with p are within the scope of a negational operator, a conditional operator or a question-operator or an non-factive verb,
then the STF value of a *sel-rest-stf* element in the CTXT BGR set of x and the M-STF value of a *sel-restr-imp* element that shares the ARG value with *sel-rest-stf* must be compatible.

How can we capture this compatibility formally? The values of M-STF and STF are a subsort of the newly-introduced *selection-sort*, cf. Fig. 2. This sort has a finite number of subsorts such as *abstract*, *physical*, *artifact*, *animate*, *edible*,... which correspond to units of a semantic ontology as in WordNet⁷ or GermaNet⁸. In Fig. 3, we roughly sketch such a semantic ontology, including multiple inheritance (sub-units inherit from more than one superunit). In such an ontology the units are related to each other, indicated by the graph-structure. We want to establish such relations between the subsorts of *selection-sort*, too.

A sort hierarchy, as used for the normal HPSG sort inventory, cannot be adopted here. An HPSG formalism for Pollard/Sag-style grammars (as RSRL e.g. Richter et al., 1999) requires that objects be sort-resolved. This allows us to talk about objects having maximally specific sorts on the one hand and about underspecified descriptions (among them lexical entries) on the other. If we had a sort hierarchy for *selection-sort* analogous to the one in Fig. 3, we could not capture generalizations such as, e. g., that *eat* takes something *edible* as its object, for *edible* is not

⁷cf. Christiane Fellbaum, ed. (1998): *Wordnet: An Electronic Lexical Database*. Bradford Books, The MIT Press.

⁸cf. <http://www.sfs.nphil.uni-tuebingen.de/lsd/>

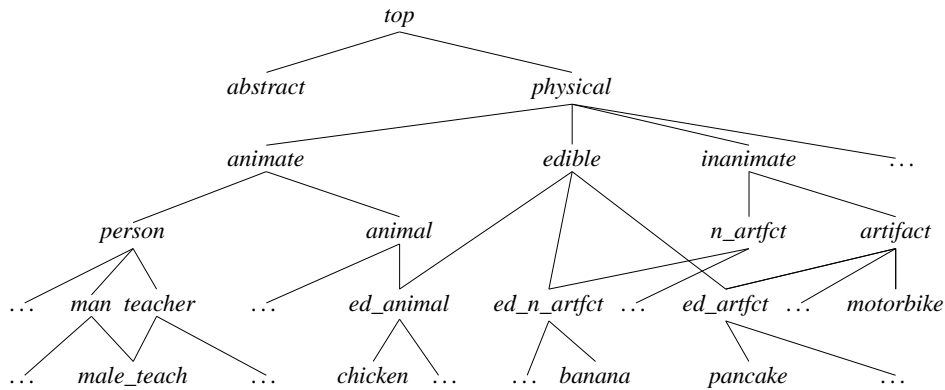

Figure 3: A semantic ontology

maximally specific. To clarify this point, we stick to our example of *eat* with the lexical constraint to have an *edible* object. Consider a concrete utterance “*She eats pancakes.*” where there is a noun-object with $[\text{STF } \textit{pancake}]$, which is the argument of a verbal object *eat* with an arbitrary, maximally specific value $[\text{M-STF } \textit{banana}]$. Even though *banana* is a subsort of *edible* (the constraint in the lexical entry of the verb thus is fulfilled), the two sorts *banana* and *pancake* are still incompatible and the selectional restriction seems to be violated. This shows that we need sorts such as *edible*, which are somewhere in the middle of the hierarchy, as values in sort-resolved objects.

Thus we insert the subsorts of *selection-sort* into the signature as depicted in Fig. 2. The relations have to be defined separately, e. g. they can be collected in a list. This list is the value of a new attribute *HIERARCHY*, which we define for all unembedded signs. It contains pairs of subsorts of *selection-sort* being in an “is a”-relation. Formally this is a partial order of the elements below *selection-sort*. The following principle describes the list and defines it as the value of *HIERARCHY* for every unembedded sign.

(14) SELECTION-HIERARCHY-PRINCIPLE (outlined):

$$\textit{unembedded-sign} \rightarrow \left[\text{HIERARCHY} \left\langle \left[\begin{array}{l} \textit{is_a} \\ \text{ARG1 } \textit{animate} \\ \text{ARG2 } \textit{animate} \end{array} \right], \left[\begin{array}{l} \textit{is_a} \\ \text{ARG1 } \textit{animate} \\ \text{ARG2 } \textit{person} \end{array} \right], \left[\begin{array}{l} \textit{is_a} \\ \text{ARG1 } \textit{animate} \\ \text{ARG2 } \textit{animal} \end{array} \right], \dots \right\rangle \right]$$

We do not mean that the *HIERARCHY*, which can easily get quite big, is a genuine “linguistic” part of every unembedded sign. We only want to express the fact that every speaker has access to this kind of knowledge when formulating or hearing an utterance. Technically but not conceptually, this amounts to the same. Defining *HIERARCHY* as a feature of *unembedded-sign* allows us to determine the grammaticality of each unembedded sign without additional context. Thus we do not have to postpone the treatment of selectional restrictions to a separate inferenc-

ing component but we can recognize the semantical ill-formedness immediately for each unembedded sign.

Returning back to our selectional restriction approach, we recapitulate: compatibility of *selection-sorts* means that there is an “is-a”-relation between the values of MUST-SATISFY and SATISFIES. This relation can contain one or more intermediate sorts; it is transitive.

(15) *She drank a sip of the Cabernet Sauvignon 2001.*

This example is about a special kind of wine. *Cabernet Sauvignon* **is** wine, which **is** an alcoholic beverage, which **is** a beverage, which **is** drinkable. The example shows that such an ontology becomes remarkably complex. At this point we have to admit that it is very easy to postulate and outline such ontologies. However, the implementation requires a lot of work, particularly when accounting for all the theoretical and empirical problems such a project raises (for a successful project cf. the one mentioned in footnote 7).

Having formalized the notion of compatibility, we can now reformulate the VPSR in the following way.

(16) VALIDITY-PRINCIPLE OF SELECTIONAL RESTRICTIONS (VPSR, final version):

If in an unembedded sign x there is a sign s , a verb v (s is an argument of v) and a proposition p , which is formed by v and its arguments, and if neither the meaning associated with s nor the meaning associated with p are within the scope of a negational operator, a conditional operator or a question-operator or an non-factive verb, then the STF value of a *sel-rest-stf* element in the CTXT BGR set of x and the M-STF value of a *sel-restr-imp* element that shares the ARG value with *sel-rest-stf* must be in a relation on the HIERARCHY list of x .

3 Summary and Further Directions

We have investigated the phenomenon of selectional restrictions and characterized it as being situated on the semantics-pragmatics-interface.

We propose a way to integrate selectional restrictions into HPSG which takes into account the effects of repairing contexts. Restrictions are imposed by the verbs in their lexical entries and have to be satisfied by the verbs' arguments. If the argument is within the scope of a repairing operator, the whole sign is not ungrammatical – it is licensed by the VPSR.⁹ Compatibility of *selection-sorts* means that

⁹One argument we have disregarded is that a violation of selectional restrictions gets repaired by a certain kind of contexts like fairy tales or science fiction stories. To account for this kind of contextual shift one would have to assume a more fine-grained structure in the CONTEXT and distinguish between a standard context and an active context. Moreover, one would need relations which can take over standard assumptions (footballs are not edible) to the actual context or which can introduce new scenarios (starships can travel faster than light).

there is an “is-a” relation between the values of MUST-SATISFY and SATISFIES. Thus we do not have to postpone the treatment of selectional restrictions to a separate inferencing component but we can recognize the semantical ill-formedness immediately for each unembedded sign.

A further application of our approach might be the handling of metonymy (see e. g. Egg, 2004). It requires a certain amount of world knowledge to understand a metonymic utterance. For example, one has to know that wine, like every other drinkable liquid, is normally stored in a container, which can be placed on a table, cf. (8). Thus, for a metonymic utterance to be felicitous, a certain relation must hold between an element in the utterance and another object, as e. g. *in_container*, *has_part* or *consists_of*. These relations could be defined for all sorts in the HIERARCHY list. As we have already implemented the *is_a*-relation there, some generalizations can be captured in an elegant way.

Our proposal implies two main lines of further research. Firstly, one could implement the approach adding it to an existing grammar fragment. The greatest portion of work in order to complete this task will be defining the HIERARCHY-list, even if one uses an already worked-out ontology. The exact specification of the VPSR depends on the kind of semantics which is implemented in the grammar fragment. Secondly, carrying out linguistic experiments would, on the one hand, provide judgements about the grammatical status of violated selectional restrictions. On the other hand, psycholinguistic evidence about the effects of repairing contexts could be produced. If it can be shown that there is a difference in processing between examples without a violation of selectional restrictions and a “repaired” violation of selectional restrictions, this would be an indication that we are on the right track.

References

- Androutsopoulos, Ion and Dale, Robert (2000). Selectional Restrictions in HPSG. In *Proceedings of COLING 2000*, Saarbrücken, pp. 15–20.
- Ben-Avi, Gilad and Francez, Nissim (2004). Categorical Grammar with Ontology-refined Types. In *Proceedings of CG 2004 (Montpellier, France)*. Elsevier.
- Chomsky, Noam (1965). *Aspects of the Theory of Syntax*. MIT Press, Cambridge, MA.
- Egg, Markus (2004). Metonymie als Phänomen der Semantik-Pragmatik-Schnittstelle. *metaphorik.de (Online-Journal)*, ISSN 1618-2006 6, 36–53.
- Müller, Stefan and Kasper, Walter (2000). HPSG Analysis of German. In W. Wahlster (Ed.), *Verbmobil: Foundations of Speech-to-Speech Translation, Artificial Intelligence*, pp. 238–253. Berlin Heidelberg New York: Springer-Verlag.

- Nerbonne, John (1996). Computational Semantics – Linguistics and Processing. In S. Lappin (Ed.), *Handbook of Contemporary Semantic Theory*, pp. 459–482. Blackwell Publishers, London.
- Pollard, Carl and Sag, Ivan A. (1994). *Head-Driven Phrase Structure Grammar*. Stanford University: CSLI/The University of Chicago Press.
- Richter, Frank (1997). Die Satzstruktur des Deutschen und die Behandlung langer Abhängigkeiten in einer Linearisierungsgrammatik. Formale Grundlagen und Implementierung in einem HPSG-Fragment. In E. Hinrichs, D. Meurers, F. Richter, M. Sailer, and H. Winhart (Eds.), *Ein HPSG-Fragment des Deutschen, Teil 1: Theorie*, Number 95 in Arbeitspapiere des SFB 340, pp. 13–187. Universität Tübingen.
- Richter, Frank (2004). *Foundations of Lexical Resource Semantics*. Professorial dissertation (version of 09-24-2004), Eberhard-Karls-Universität Tübingen.
- Richter, Frank, Sailer, Manfred, and Penn, Gerald (1999). A Formal Interpretation of Relations and Quantification in HPSG. In G. Bouma, E. Hinrichs, G.-J. M. Kruijff, and R. Oehrle (Eds.), *Constraints and Resources in Natural Language Syntax and Semantics*, pp. 281–298. Stanford: CSLI Publications.
- Soehn, Jan-Philipp and Römer, Christine (2004). Wann ist ein Idiom ein Idiom? Eine Analyse von Phraseologismen ohne freie Lesart. In *Proceedings of Europhras 2004, Basel*.