

# **The Syntax of Copular Construction in Mauritian**

Fabiola Henri & Anne Abeillé  
fhenri@linguist.jussieu.fr, abeille@linguist.jussieu.fr

LLF, University Paris 7

Proceedings of the HPSG07 Conference

Stanford Department of Linguistics  
CSLI LinGO Lab  
Stanford University

Stefan Müller (Editor)

2007

CSLI Publications

<http://csli-publications.stanford.edu/>

## Abstract:

This paper<sup>†</sup> examines the syntactic behavior of the Mauritian copula in predicative and extracted sentences. As it is the case in many languages, the Mauritian copula *ete* is absent in certain constructions: It only appears in extraction contexts. Our aim is to show that the postulation of a null copula, which has been proposed in various analyses, is inadequate for the Mauritian data. The phenomenon, as it is argued, rather lends itself to a strictly construction-based analysis within the framework of HPSG and is based on the distribution of weak pronouns and TAM markers.

## 1 Introduction

Schachter 1985; 1984 defines *copulas* as words that are used to indicate the relation between a subject and a nominal or adjectival predicate. In our analysis, we will extend Schachter's definition to prepositional phrases as well hence accounting for all types of non-verbal predicate. In this sense, it is a lexical verb as opposed to that of being a helping verb when used as an auxiliary. This opposition, which is found in languages like French, English and so on, is not available in Mauritian (henceforth MC) since in this language it is only a main verb appearing in specific contexts. In fact, the copula *ete* in MC fails to appear in declaratives with a predicative complement but is present in extraction contexts. The aim of this paper is to demonstrate that the analyses proposed to account for absent copulas in the many languages where the phenomenon is present namely Creoles- Haitian (Déprez 1997, Gadelii to appear), Mauritian (Syea 1997), German (Müller 2006), African American Vernacular English (Bender 2001) to name but a few, is unmotivated for the data examined in Mauritian- a French-based Creole. These have indeed reached the conclusion that the specific behavior of the copula in these languages could only be accounted for if a null copula is postulated in contexts where it is absent and a corresponding full form where it appears. Syea 1997, within the framework of Government and Binding, for instance, base his analysis on the ECP and assumes that the copula is needed for the trace to be properly governed. The proposition, however, doesn't account for the specific behavior of weak and strong forms of personal pronouns, TAM markers as well as the negation marker. In a constraint-based framework like HPSG, Müller to appear. adopts the null copula analysis in order to preserve the topological fields in German when the copula is omitted in declaratives while Bender (2001) cannot account for long distance dependencies without a phonologically null element in AAVE because in these constructions the copula is still missing. The paper shows that the arguments motivating these analyses do not account for the studied data given that the Mauritian

---

<sup>†</sup>We wish to thank Olivier Bonami, Robert Borsley, Danièle Godard, François Mouret, Stephan Müller and Ivan Sag for their comments and feedback on this paper. All remaining mistakes are of course our own.

copula do not behave like Haitian's or AAVE copula. Furthermore, Müller's account essentially adopts a lexicalist approach over a phrasal one because of the complexity of the former in accounting for the different linearization of a particular phenomena. Both types of analysis have advantages and disadvantages which we will discuss throughout the paper. The latter is organized as follows: Section 2 reviews the historical background pertaining to the emergence of the copula in Mauritian, section 3 presents the relevant data, section 4 reviews briefly the proposed analyses and their problems, section 5 presents an alternative analysis within HPSG and finally section 6 concludes the discussion.

## 2 (Historical) Background

In his *Etude sur le Patois Creole Mauricien*, Baissac 1880 states that "(...)Le créole en est resté à cette proposition embryonnaire. Le concept de l'existence sans attribut est trop haute pour lui, il ne s'élève jamais jusqu'à ces abstractions. Le verbe substantif, essentiel, le verbe "être" n'existe pas en créole." P32 <sup>1</sup>. Although it is true that the copula emerged in the late 19th century<sup>2</sup>, the author strikingly analyzes it as a variant of the past tense marker *ti*. The confusion, no doubt, results from historical facts. A form *ete/te* can actually be found in old texts where it is clearly a tense marker<sup>3</sup>:

(1) Moy napa ete batte ça blanc la. (1779: Chaudenson 1981)

(2) Quequ'fois cabrit moi te manze. (Chrestien 1831)

In both sentences, *ete/te* is a helping verb and *batte* and *manze* are the main verbs. These ancient forms can indeed be substituted by the past tense marker whose contemporary form is *ti*. This tense marker, which can appear with verbs, can also stand alone in declaratives as will be seen later in this paper as opposed to *ete*, which is a lexical verb ( $\neq$  auxiliary).

(3) Kot Zan ti ale?  
 where John PST go  
 'Where did John go?'

(4) Kot zan (\*ete) ale?

Schachter (1985) and Déprez (2000) distinguishes between **predicators** and **copulas** where the former are used to mark predicate nominals when there is no overt subject. The idea in raising up this point is to see whether other elements

<sup>1</sup>(...) Creole has remained at the level of this embryonic proposition. The concept of existence without attribute is way to high for him, he never rises to these abstractions. The substantive verb, which is essential, the verb 'to be' doesn't exist in Creole.)

<sup>2</sup>See Baker & Syea (1991) for more details

<sup>3</sup>The data are taken from Baker & Syea 1991. See also Corne 1980, 1982.

such as *se*, from French *c'est*, can be analyzed as a copula as has been proposed for Haitian Creole (Déprez 2000) or as a proform, i.e. the subject of an expletive type of construction. Considering the following data, it can be argued that compared to HC where *se* is obligatorily present when the predicate is indefinite as in (7), MC never admits *se* as a copula (6b).

(5) (Se) tifi la ki pa'nn vini.  
 It girl DEF REL NEG.PERF come  
 'It is the girl who didn't come.'

(6) a. tifi la (\*se) profeser.  
 girl DEF it teacher  
 'The girl is a teacher.'

b. tifi la enn profeser.  
 girl DEF DET teacher  
 'The girl is a teacher.'

c. tifi la, se enn profeser.  
 girl DEF it DET teacher  
 'The girl, she is a teacher.'

(7) Jan (\*se) yon dokter. HC  
 Jan SE a doctor  
 'John is a doctor.'

In (6c), where it seems to behave like a copula, *se* is a presentational pronoun. Compare for instance (6b) to (6c) where the latter is clearly a dislocation as can be seen from the English translation. Moreover there is a difference between the two sentences: when *se* is present there is a pause marking dislocation in the prosody. We thus consider that *se* is a presentational pronoun. In the next section, we consider the data and propose alongside some preliminary analyses of the different constructions.

### 3 The data

#### 3.1 Verbless copular sentences

MC has an absent copula in non-extracted declaratives whether the predicate is adjectival, prepositional or nominal, whether in the past, present or future and whether the predicate is negated or not as exemplified in (8)-(10).

(8) a. Zan (\*ete) (enn) profeser.  
 John COP a teacher  
 'John is a teacher.'

- b. Zan (\*ete) dan lakour.  
John COP PREP garden  
'John is in the garden.'
- c. Zan (\*ete) malad.  
John COP sick  
'John is sick.'

(9) a. Zan pa (\*ete) (enn) profeser.  
John NEG COP (a) teacher  
'John is not a teacher.'

b. Zan pa (\*ete) dan lakour.  
John NEG COP PREP garden  
'John is not in the garden.'

c. Zan pa (\*ete) malad.  
John NEG COP sick  
'John is not sick.'

(10) a. Zan ti (\*ete) (enn) profeser.  
John PST COP (a) teacher  
'John was a teacher.'

b. Zan ti/pou (\*ete) dan lakour.  
John PST/IRR COP PREP garden  
'John was/will be in the garden.'

c. Zan ti/pou (\*ete) malad.  
John PST/IRR COP sick  
'John was/will be sick.'

Note that in (10a), we have deliberately excluded the irrealis marker *pou*. With this marker, the verb *vinn* is needed in order to denote process.

(11) Zan pou (\*ete) vinn (enn) profeser.  
John IRR COP become (a) teacher  
Lit. 'John will become a teacher.'

Similar to AAVE (Bender 2001), these verbless sentences behave as finite clauses in the sense that they can be embedded and coordinated with verbal clauses:

(12) a. Mo krwar/panse Zan (\*ete) (enn) profeser.  
1SG believe/think John COP (a) teacher  
'I believe/think that John is a teacher.'

- b. Mo krwar/panse Zan (\*ete) dan lakour.  
 1SG believe/think John COP PREP garden  
 'I believe/think that John is in the garden.'
- c. Mo krwar/panse Zan (\*ete) malad.  
 1SG believe/think John COP sick  
 'I believe/think that John is sick.'

(13) Mo pe ale e Zan (\*ete) kontan.  
 1SG PROG go and John COP happy  
 'I'm leaving and John is happy.'

The prediction is also true when the embedded clause or second conjunct is negated, or when TAM markers are present as illustrated in (14) and (15).

- (14) a. Mo krwar/panse Zan ti (\*ete) (enn) profeser.  
 1SG believe/think John PST COP (a) teacher  
 'I believe/think that John was a teacher.'
- b. Mo krwar/panse Zan pa (\*ete) dan lakour.  
 1SG NEG believe/think John NEG COP PREP  
 garden  
 'I believe/think that John is not in the garden.'
- c. Mo krwar/panse Zan pa ti (\*ete) malad.  
 1SG believe/think John NEG PST COP sick  
 'I believe/think that John was not sick.'

(15) Mo pe ale e Zan pa (\*ete) kontan.  
 1SG PROG go and John NEG COP happy  
 'I'm leaving and John is not happy.'

It seems then that in MC there is no element linking the predicate to its subject in declaratives clauses. A lexical form having the properties of a copula somehow surfaces in particular constructions as will be illustrated in the next section.

### 3.2 Distribution of the copula *ete*

As mentioned earlier, a lexical form *ete* appears in specific constructions, namely in extraction contexts: in direct (16) and indirect interrogatives (17), in topicalisations (18), in relatives clauses (19), clefts (20) and exclamatives<sup>4</sup> (21) (% means that the data is not accepted by all speakers).

- (16) Ki tifi la \*(ete)?  
 what girl DEF COP  
 'What is the girl?'

---

<sup>4</sup>Syea 1997 discusses such data, but does not include exclamatives.

(17) mo pa kone ki tifi la \*(ete)  
1SG NEG know what girl DEF COP  
'I don't know what this girl is.'

(18) en voler zan \*(ete)  
A thief John COP  
A thief John is.

(19) Sa madam ar ki li \*(ete) la  
DEM woman with REL 3SG COP  
'The woman with whom he is.'

(20) pares ki li \*(ete)  
lazy COMP 3SG COP  
'It is lazy that he is.'

(21) % ala enn bon dokter li \*(ete) la!  
DEIC a good doctor 3SG COP DEIC  
'What a good doctor he is!'

That the predicate is extracted is shown by the fact that we can have a long distance dependency as in (22).

(22) kisannla to panse tifi la \*(ete)?  
who 2SG think girl DEF COP  
'Who do you think this girl is?'

It is thus predicate extraction that triggers the lexical realization of the copula. In interrogatives with an in-situ *wh*-word (23), or with a *wh*-subject, the copula is impossible (24) even if the subject is extracted. It is also impossible if only a complement of the predicate is extracted (26). The same applies in relative clauses where the subject is relativized (27) and in exclamatives with no extraction (28).

- (23) a. Zan \*(ete) kote?  
John COP where  
'John is where?'
- b. Tifi la \*(ete) ki manier?  
girl DEF COP how way  
'The girl is how?'

(24) kisannla \*(ete) malad?  
who COP sick  
'Who is sick?'

- (25) *kisannla to panse ki (\*ete) malad?*  
 who 2SG think that COP sick  
 'Who do you think is sick?'
- (26) *kont kisannla Zan (\*ete) ankoler?*  
 against who John COP angry  
 Lit. 'Against whom John is angry?'
- (27) *Sa madam ki (\*ete) malad...*  
 the woman REL COP sick  
 The woman who is sick...
- (28) *% Ala Zan (\*ete) zoli la!*  
 DEIC John (COP) beautiful DEIC  
 'How beautiful John is!'

Finally, when a locative or manner predicate is extracted, the lexical copula appears to be optional in interrogatives:

- (29) *Kot Zan (ete)?*  
 where John COP  
 'Where is John?'
- (30) *Ki manier madam la (ete)?*  
 how way woman DEF COP  
 'How is the woman?'
- (31) *Komye liv la (ete)?*  
 how book DEF COP  
 'How much is the book?'
- (32) *Dan lakour, Zan \*(ete)*  
 PREP garden, John COP  
 'In the garden, John is.'

The data can be summarized in the table below.

	impossible <i>ete</i>	optional <i>ete</i>	obligatory <i>ete</i>
Declaratives	no extraction	-	topicalisation: loc.pred
Interrogatives	wh-subj/in-situ	wh-loc/manner..	wh-pred.
Relatives	subj.rel.	-	pred.rel loc.rel
Exclamatives	no extraction	-	wh-pred

Notice that *ete* is not necessarily in final position. It can be followed by various PPs or adverbial modifiers as seen from the following examples.

(34) Ki Zan \*(ete) dan sa lekol la?  
what John COP PREP DEM school DEF  
'What is John in this school?'

(35) Kot Zan (ete) zordi?  
where John COP today  
'Where is John today?'

Given the data, we thus analyze *ete* as a head selecting for a gap predicative complement.

#### 4 Proposed analyses

In HPSG, two main types of analysis have been proposed for verbless clauses: a construction-based approach (as in Sag & Wasow 1999 and Ginzburg et Sag 2000) and a lexicalist approach, based on a phonologically null copula form, as in Bender (2001, 2003), Borsley (2004) and (Müller 2006). We argue here in favor of the former.

In her analysis, Bender 2001 argues that the only way of accounting for the behavior of the copula in AAVE is to allow that the copula is phonologically null whenever it is deleted. The fact that the verb can be deleted in long distance dependencies poses a serious problem if we are to propose a constructionist approach.

(36) How old you think his baby  $\emptyset$ ?

The proposed analysis suggests that the empty copula for AAVE be treated as one of the inflected forms of *be*. A lexical rule applies to the verb verb projecting a null form providing a way to account for sentences such as (36) above. In the case of MC as in (37a) below *ete* is obligatory and hence the proposed analysis cannot be applied to the data.

(37) a. Ki kouler to krwar so sak \*(ete)?  
how color 2SG believe 3SG.POSS bag COP  
'What color you believe his bag is.'

b. Kot to panse so mama \*(ete)?  
where 2SG think 3SG.POSS mother COP  
'Where do you think his/her mother is.'

Borsley 2004, when looking at the comparative-correlative construction in English, suggests that the verb *be* have particular properties since it can be omitted in some CC constructions as in (38).

(38) the more intelligent the students (are), the better the marks (are).

In his analysis, he suggests that a verb *be* can be a phonologically null form only in head-filler phrases. That is, in these constructions where copula omission is possible if and only if its complement is fronted as in (36), the head can be phonologically null with a feature [NULL+]. The lexical description of the null form *be* ensures that its COMPS value is empty in order to avoid in-situ complements while the feature SLASH provides the value of the element to be fronted. The analysis provided by Borsley (2004) does not account for the facts in MC. If a null element can only be accounted for in Head-filler phrases, declaratives without extraction are excluded. And in (34) above, if the complement is fronted, the copula is still obligatory.

(39) Dan sa lekol la, ki Zan \*(ete)?  
PREP DEM school DEF what Zan COP  
In this school, what is John?

In the same kind of constraint-based grammar, Müller to appear. accounts for copula omission in German via a lexical rule as has been proposed for AAVE (Bender 2001<sup>5</sup>). The argument relies on the fact that the clause type determination in German is changed if a constructionist approach is adopted. That is, although the copula doesn't have any semantic contribution to the sentence, there is a need to preserve the order domain because of sentence structure. He furthermore argues that empty elements is to be favored in German when it comes to ellipsis, like for instance ellipsis of NPs, given the fact that without those, the semantics cannot be recovered. A second argument in favor of phonologically null elements versus a construction-based approach concerns the production of multiple phrase-structure rules in the type hierarchy. That is favoring a lexical approach is certainly more economical in terms of rules than a constructionist approach. However, it can be argued that the same problem arises with a lexical-based account, in the sense that we multiply lexical entries. Moreover, in his account no lexical entry is provided<sup>6</sup> for the empty copula and hence, we are not able to see how it could interact with the phrase structure rules for German.

Finally, Syea 1997 in the Government and Binding framework, proposes two forms of the copula for the MC data, a weak form (which is null) and a strong form (which is *ete*). Syea's Generalization says that "the copula has the weak form in the environment of a following overt constituent and the strong form in the environment of a following trace". As already mentioned in the introduction paragraph, his analysis is based on the ECP which says that traces must be properly governed, assuming that the null copula cannot be a proper governor. The proposal is that

---

<sup>5</sup>See also Ferguson (1968) for a different analysis.

<sup>6</sup>Actually, he send us back in a footnote to Bender's analysis (Bender, 2001).

head-government requirement should apply at PF, while antecedent-government requirement should apply at LF, since the copula, being semantically void, does not exist at LF.

#### 4.1 Against a null copula

Our main argument against a null copula analysis is based on the distribution of weak pronouns *mo* and *to*, the negation marker *pa* and TAM markers *ti*, *pou* and so forth. Weak forms of the 1st and 2nd personal pronouns (*mo* and *to*) can appear in verbless copular sentences but not in case of an extraction, unlike strong forms *mwa* and *twa*:

(40) To dan lakour  
2SG PREP garden  
'You are in the garden.'

(41) Kot to \*(ete)?  
where 2SG COP  
'Where are you?'

(42) Kot twa?  
Where 2SG.OBJ  
'Where are you?'

If a null copula is involved in (40), and legitimates the weak form of the pronoun, then it should also be allowed in (41) since the null copula is compatible with an extracted locative with an NP subject as in (29). If we analyze weak pronouns as proclitics (looking for a phonological host to their right), then (41) is bad with an empty copula. The same behavior is witnessed with the negation marker and the TAM markers.

(43) Kot Zan ti \*(ete)?  
where John PST COP  
'Where was John?'

(44) Kot Zan pa \*(ete)?  
where John NEG COP  
'Where wasn't John?'

Since the null pronoun is allowed with these markers in declaratives it should be the case with the extracted locatives, which as seen above are ungrammatical. If we analyze the negator as a modifier seeking a host and TAM markers as raising verbs, then the ungrammaticality of (43) and (44) can be explained by the fact that they are missing their complements. We thus say that they subcategorize for a canonical complement (which can be a finite VP or a predicative XP). Furthermore,

as has been argued earlier the proposal made by Bender (2001), Borsley (2004) and Müller (2006) does not apply to the studied data since the optionality of the copula in these languages is based on factors different from those available in MC. In the next section, we provide an alternative analysis in HPSG<sup>7</sup> inspired from Sag & Wasow (1999).

## 5 A Construction-based HPSG Analysis

In Sag & Wasow 1999, a Zero Copula Rule is proposed whereby [PRED+] expressions (predicative expressions) can combine with a nominative subject to project a fully saturated phrase structure. In other words [PRED+] expressions are able to project finite clauses even if they are missing a verb. This is possible given that the copula is semantically empty. We first provide the necessary lexical entries for TAM markers and the copula and the relevant mechanisms allowing the parsing of the extracted contexts where the copula *ete* is present and copulaless ones where it is missing.

### 5.1 Lexical entries for *ete*, *ti* and *pa*

We analyze the copula as a verb which is constrained to take a predicative complement of the type *gap*. A TAM marker like *ti*, on the other hand, is constrained to take a finite VP or predicative complement of the type *canonical*. Finally, the negator *pa* modifies a predicative or verbal head in sentential negation.

$$(45) \left\langle \text{ete}, \left[ \text{ARG-ST} \left\langle \left[ \begin{array}{l} \text{gap} \\ \text{PRED +} \\ \text{SUBJ} \left\langle \left[ \square \right] \right\rangle \end{array} \right] \right\rangle \right] \right\rangle$$

$$(46) \left\langle \text{ti}, \left[ \text{ARG-ST} \left\langle \left[ \begin{array}{l} \text{canon} \\ \text{PRED + or verb} \\ \text{SUBJ} \left\langle \left[ \square \right] \right\rangle \end{array} \right] \right\rangle \right] \right\rangle$$

$$(47) \left\langle \text{pa}, \left[ \begin{array}{l} \text{adverb} \\ \text{MOD} \left[ \begin{array}{l} \text{PRED + or verb} \\ \text{CONT | NUCLEUS} \left[ \square \right] \end{array} \right] \\ \text{STORE} \left[ \begin{array}{l} \text{neg-quant-rel} \\ \text{ARG} \left[ \square \right] \end{array} \right] \end{array} \right] \right\rangle$$

When the locative (or manner and so forth) complements are analyzed as [PRED +], they can be extracted and the copula thus surfaces. This is illustrated in (48) below.

<sup>7</sup>See also Pollard & Sag 1994.

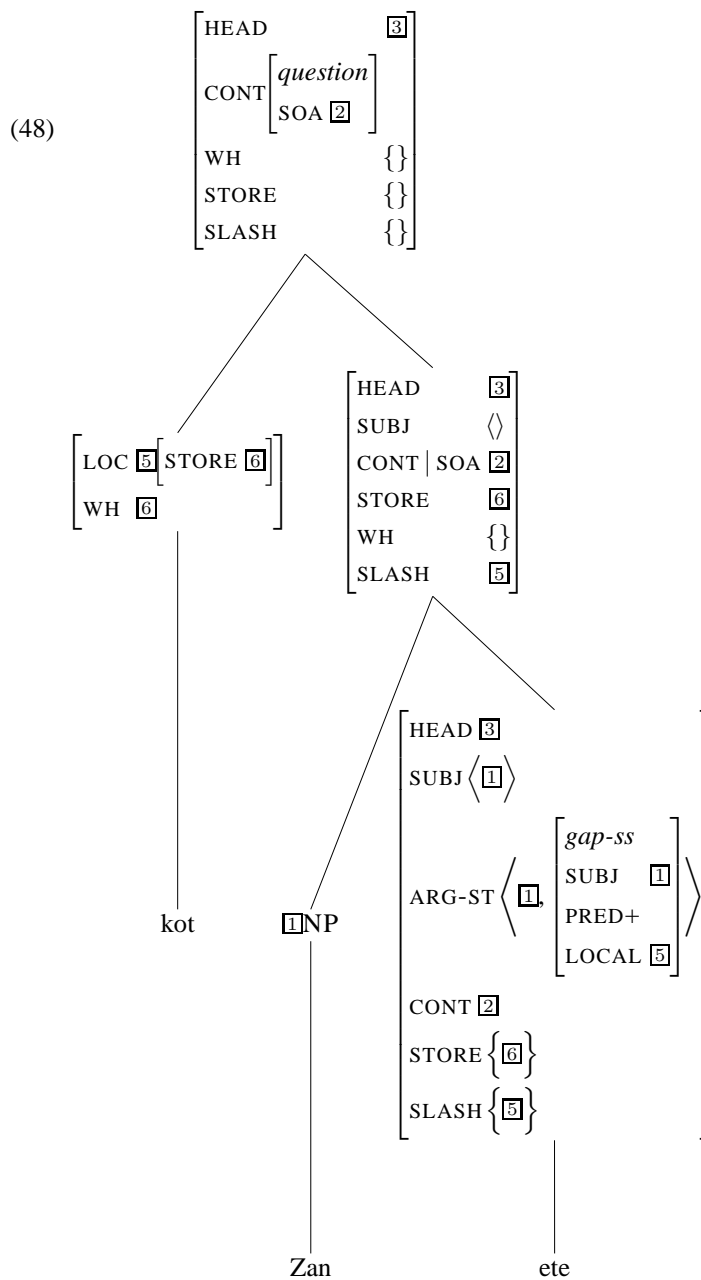

## 5.2 Our analysis of verbless clauses

Following (Sag & Wasow 1999), we handle verbless copular clauses with a specific construction, with a non verbal head, which is a subtype of head-subject phrases, assuming that the Head Feature Principle is a default constraint and that our verbless copular-construction rule here overrides the default constraint as suggested by

Ginzburg & Sag 2000<sup>8</sup>.

$$(49) \text{ verbless-cop-cx} \rightarrow \text{head-subj-phrase} \& \left[ \begin{array}{l} \text{SYNSEM} \left[ \begin{array}{l} \text{HEAD} \left[ \begin{array}{l} \textit{verb} \\ \text{VFORM} \quad \textit{fin} \end{array} \right] \\ \text{CONT} \left[ \begin{array}{l} \textit{message} \\ \text{SOA} \mid \boxed{2} \end{array} \right] \end{array} \right] \\ \text{HEAD-DTR} \left[ \begin{array}{l} \text{HEAD} \quad \textit{non-verbal} \\ \text{CONT} \mid \text{NUCL} \quad \boxed{2} \end{array} \right] \end{array} \right]$$

This construction inherits from the head-subject phrase, which ensures that the subject is appropriate for the head. MC, unlike French, does not generally allow subject inversion. We thus have a precedence rule that forces the subject to precede the (non-verbal) head, accounting thus for the facts in declaratives.

$$(50) \text{ HEAD-SUBJ-PHR} \rightarrow \text{NON-HD-DTR} \quad \text{precedes} \quad \left[ \left[ \text{PRED} + \right] \vee \left[ \text{VFORM} \quad \textit{fin} \right] \right]$$

Recall that in the types definitions of core clauses we include declarative clauses and interrogatives clauses, among others. The former have a CONTENT value of type *message* while the latter, i.e., declarative clauses and interrogative clauses, which are its subtypes, have a CONTENT of type *proposition* and *question* respectively.

$$(51) \text{ a. } \textit{clause} \rightarrow \left[ \begin{array}{l} \text{STORE} \{ \} \\ \text{WH} \{ \} \\ \text{HEAD} \text{ PRED+ or } \textit{verb} \\ \text{CONT} \textit{ message} \end{array} \right]$$

$$\text{ b. } \textit{decl-clause} \rightarrow \textit{clause} \& \left[ \text{CONT} \textit{ proposition} \right]$$

$$\text{ c. } \textit{inter-clause} \rightarrow \textit{clause} \& \left[ \text{CONT} \textit{ question} \right]$$

---

<sup>8</sup>The idea was first suggested by Copestake & Lascarides (1999)

(52)

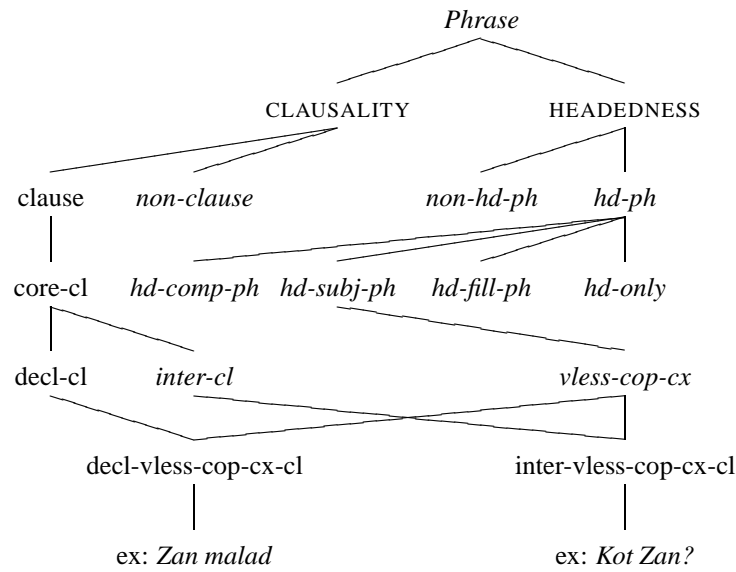

In addition, our constraint only applies to verbal or predicative head daughters. By requiring that verbless constructions or predicative phrases project a  $[VFORM \textit{fin}]$ , (48) guarantees that these can function as finite clauses in that they can, for instance, be embedded and coordinated. Notice also that our construction has a CONTENT of type *message* meaning that it can account for more specific types like *proposition* for a non-extracted declarative and *question* for verbless interrogatives (29, 30), with both a PRED+ as HEAD feature, as illustrated in the type-hierarchy.

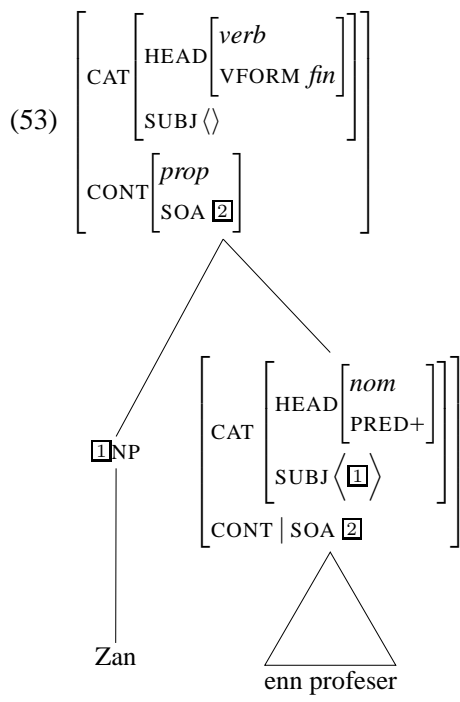

(54)

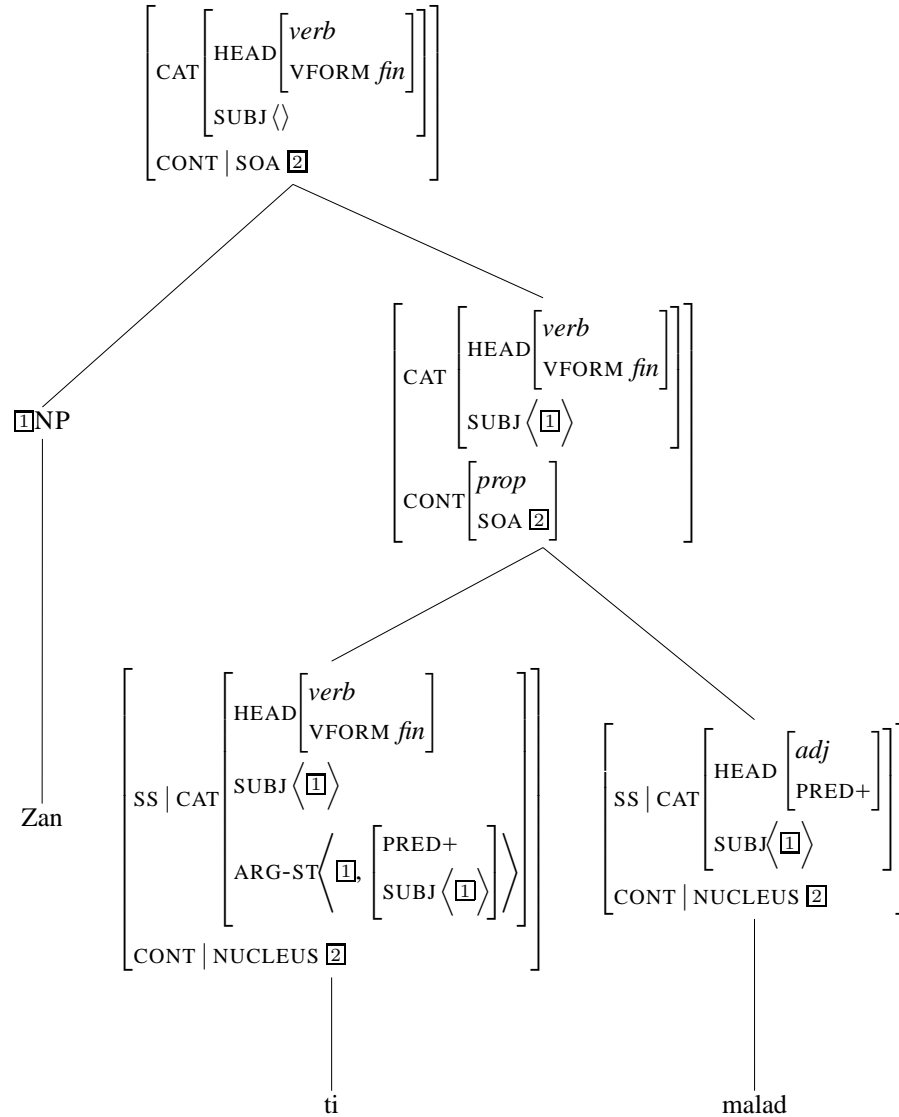

We analyze locative and manner *wh*-predicates as ambiguous in this respect, in the sense that they are underspecified for the PRED feature. If they are [PRED -], they can be analyzed as heads and can precede the subject, and this is how examples in (29) and (30) above without the copula can be analyzed. That *kot* is not extracted in (29) (i.e. the example without *ete*) is shown by the fact that we don't have a long distance dependency without *ete* as illustrated in (37a) and below. The same applies to manner adverbials.

- (55) a. *Kot to panse zan \*(ete)?*  
 where 2SG think John COP  
 'Where do you think John is?'

- b. Ki manier to panse zan \*(ete)?  
 what manner 2SG think John COP  
 'How do you think John is?'
- c. Komye to krwar lasenn la \*(ete)?  
 How-much 2SG believe necklace DEF COP  
 'How much do you believe the necklace is?'

However, as has been argued in Müller 2006, a phrasal approach is problematic given that for languages that have free constituent order like German, a large number of constructions are needed to cover all the patterns that can be found for a given phenomena. Although, these results being interesting and absolutely convincing, we need not forget that this stipulation is valid for German and that we are presupposing the existence of a null form if and only if a full form exists in the same slot. For example, in German the copula can be omitted in declaratives. The same applies to the AAVE copula. In the case of MC, the copula is optional only with adverbials (locative, manner and so forth). In declaratives, the copula is not allowed at all (3.1) unless with extraction. Hence, it makes no sense to postulate a null form in a slot where a full form is not allowed. Moreover, Mauritian being a rather strict SVO, will not face the problems encountered by German with a construction-based analysis. Albeit, allowing a phonological null form is still conceivable. Our lexical entries for TAM markers, negation and subject pronouns will have to be modified to allow a canonical complement with feature NULL+<sup>9</sup> as one of the HEAD value; although our lexical entry for the negator, for instance, would be much more complicated. The lexical entry of the phonologically null element would be as such:

$$(56) \left[ \begin{array}{l} \text{VFORM } \textit{fin} \\ \text{NULL+} \\ \text{ARG-ST } \left\langle \boxed{1}, \left[ \begin{array}{l} \textit{canon} \\ \text{PRED+} \\ \text{SUBJ } \left\langle \boxed{1} \right\rangle \right] \right\rangle \end{array} \right. \end{array} \right]$$

## 6 Conclusion

We have, in this paper, argued against a null copula for Mauritian verbless copular clauses, and in favor of a construction-based analysis. The peculiar distribution of the lexical copula *ete* and the TAM markers in copular clauses also provide some support for a lexicalist theory of extraction, as advocated by Bouma & al 2001. A more precise analysis of the semantics of the construction, as well as an extension to comparative clauses, which can also appear with or without the copula, still need to be provided.

<sup>9</sup>The idea is from Borsley 2004.

## References

- Baissac, C. 1880. *Etude sur le Patois Créole Mauricien*. Nancy: Berger-Levrault.
- Baker, P. & Sycé A. 1991. On the copula in Mauritian Creole: Past and Present. In T. Byrne, F. & Huebner (ed.), *Development and Structures in Creole Languages*, pages 159–175, Amsterdam: Benjamins.
- Bender, E. 2001. *Syntactic Variation and Linguistic Competence: The Case of AAVE Copula Absence*. Ph. D. thesis, Stanford University, Stanford, California.
- Bouma G, Malouf R. & Sag I. 2001. Satisfying Constraints on Extraction and Adjunction. *Natural Language and Linguistic Theory* 1(19), 1–65.
- Corne, C. 1980. A re-evaluation of the predicate in Ile-de-France Creole. In P. Muskyen (ed.), *Generative Studies on Creole Languages*, pages 103–124, Dordrecht: Foris.
- Corne, C. 1982. The Predicate in Isle de France Creole. In C. Baker, P. & Corne (ed.), *Isle de France Creole. Affinities and Origins*, pages 31–48, Karoma: Arbor.
- Deprez, V. & Vinet, M-T. 1997. Predicative Constructions and functional categories in Haitian Creole. *Journal of Pidgin and Creole Languages* 12, 203–235.
- Ferguson, C. 1968. Absence of Copula and the Notion of Simplicity. In D. Hymes (ed.), *Pidginization and Creolization of Languages*, Cambridge: CUP.
- Gadellii, K. to appear. Les phrases copulatives dans les créoles français .
- Ginzburg, J. & Sag, I. 2000. *Interrogative Investigations: The form, meaning and use of English Interrogatives*. Stanford: CSLI Publications.
- Müller, S. 2006. Phrasal or Lexical Constructions? *Language* 82(4), 850–883.
- Müller, S. to appear. Elliptical Constructions, Multiple Frontings, and Surface-Based Syntax. Proceedings of Formal Grammar 2004, CSLI Publications.
- Pollard, C. & Sag, I. 1994. *Head-Driven Phrase Structure Grammar*. Stanford: CSLI Publications.
- R., Borsley. 2004. An Approach to English Comparative Correlatives. On-line Proceedings of the HPSG-2004 Conference, pages 70–92, Center for Computational Linguistics, Katholieke Universiteit Leuven.
- Sag, I. & Wasow T. 1999. *Syntactic Theory: A Formal Introduction*. Stanford: CSLI Publications.
- Sag I., Bender E. & Wasow T. 2003. *Syntactic Theory: A Formal Introduction. 2nd Ed.*. Stanford: CSLI Publications.

- Schachter, P. 1984. Auxiliary reduction: An argument for GPSG. *Linguistic Inquiry* 15, 514–523.
- Schachter, P. 1985. Pronouns. In T. Schopen (ed.), *Language typology and syntactic descriptions*, pages 68–74, Cambridge: CUP.
- Syea, A. 1997. Copula, wh-trace, and the ECP in Mauritian Creole. *Linguistics* 35, 25–56.