

Complex Topic-Comment Structures in HPSG

Gert Webelhuth

University of Göttingen

Proceedings of the HPSG07 Conference

Stanford Department of Linguistics and CSLI's LinGO Lab

Stefan Müller (Editor)

2007

CSLI Publications

<http://csli-publications.stanford.edu/>

Abstract

Based on Krifka (1992) and de Kuthy (2000), this paper develops an architecture for complex topic-comment structures in HPSG and applies it to predicate fronting in English with the goal of capturing the insights of Ward (1988) on this construction. We argue that predicate fronting is a distributed constructional form consisting of an auxiliary occurring in a predicate preposing phrase. The use of predicate preposing is a function of a combination of simultaneous constraints on its theme structure, its background-focus distribution, and its presuppositional structure. It is shown that these constraints can be made explicit within the HPSG architecture developed here.

1 Non-canonical Syntactic Constructions

Höhle (1982) has argued that non-canonical syntactic constructions in German typically have fewer information structural options compared to canonical sentence patterns. The same has been argued for English. Ward (1988) concludes that the preposing constructions in (1)-(2) require the (meaning of the) preposed constituent to be a backward looking center. Similarly, Birner (1996) shows that inversion constructions like (3) are felicitous only if the preposed constituent is at least as discourse-familiar as the postposed NP:

- (1) *One of these rugs* Chambers delivered TO HARRY DEXTER WHITE.
- (2) (It was necessary to pass the exam and) *pass* I DID.
- (3) *On the desk* was A BIG LAMP.

There is a generalization that cuts across these English constructions and others:¹ in their prototypical use

1. the italicized constituent is the leftmost constituent of its predicate-argument complex, and
2. it is followed by another constituent of the same predicate-argument complex which is prosodically more prominent than it;
3. each sentence is more “about” the meaning of the italicized constituent than the meaning of the constituent in small caps (backgrounded, contrastive topic).

[†]I would like to thank Dorothee Beermann, Betty Birner, Regine Eckardt, Lars Hellan, Kordula de Kuthy, Detmar Meurers, Ivan Sag, Manfred Sailer, Gautam Sengupta, the members of the CoGETI research network and the audience at HPSG 2007 for discussions and comments at various stages during the development of the theory presented in this article. The responsibility for all errors remains with me.

¹The generalization extends to German as well.

Previous work on information structure in HPSG (e.g. Vallduvi (1992)) has not derived this generalization. The work reported here is part of a larger research project which aims at developing a theoretical architecture that makes it possible to state this generalization in HPSG while also accounting for the properties specific to each non-canonical sentence pattern. The present article will only deal with a small portion of this subject matter, namely predicate preposing.

2 Case Study: Predicate Preposing

Ward (1988) provides the following attested examples of predicate topicalization sentences:²

- (4) As members of the Gray Panthers committee, WE WENT TO CANADA TO LEARN, and *learn we did*.
[*Philadelphia Inquirer*, 6/16/85]
- (5) THE KING HAS INSTRUCTED ME TO BE BRIEF, and since I am His Majesty's loyal subject, *brief I will be*.
[*A Man for All Seasons*, Messenger]

He arrives at the following conclusion concerning the felicitous use of this sentence form:

Ward's Generalization Ward (1988)

Predicate preposing is associated with the function of proposition affirmation. Proposition affirmation serves to affirm a proposition explicitly evoked in the discourse.

The contrast in (6) serves to illustrate this analysis. (6c) cannot felicitously follow (6a), since the proposition affirmed by (6c), namely that *I have enough money* is not explicitly introduced into the discourse by (6a). That there is nothing wrong with this sequence of meanings in principle is shown by (6b) which can felicitously follow (6a). The difference is that unlike predicate preposing the emphatic do-support construction (the *verum focus* of Höhle (1992)) does not require the proposition it affirms to have been *explicitly* evoked in the previous discourse:

- (6) a. I want to buy a car.
b. And I DO have enough money.
c. # And *have enough money I DO*.

As predicted by Ward's assumptions, if (6c) is put into a discourse context where the affirmed proposition has been introduced explicitly, its use becomes felicitous:

- (7) They said I WOULDN'T HAVE ENOUGH MONEY TO BUY A CAR, but *have enough money I DO*.

²Most of the examples in this article that relate to predicate preposing are taken from Ward (1988), by far the most careful and sophisticated study of the construction.

3 Towards an Architecture for Information Structure in HPSG

The theory of the relationship between syntax, semantics, and information structure developed below is based on the assumption that there are dependencies and inter-relations between meanings and context that can only be expressed by a semantic representation language that makes reference to objects of specific semantic types, in particular properties (or their extensions). Moreover, it should be possible to impose discourse-anaphoric requirements on semantic pieces of constructions (and likely also rhetorical relations). A natural choice for this purpose is Discourse Representation Theory (Kamp and Reyle (1993)), in particular Lambda-DRT, because the latter is typed.

Another important question that arises concerns the degree of articulation of the information structure. Krifka (1992) and Jacobs (2001) draw a four-way distinction between topic-comment and background-focus. de Kuthy (2000), in essence following Vallduvi (1992), distinguishes between background and focus and adds a (contrastive) topic in the sense of Büring (1997). For the purposes of this paper, the three-way distinction appears to be sufficient and I will consequently adopt it. Borrowing from the Prague School, Halliday (1967) develops the concepts *theme* which for him is the starting point of an utterance, its leftmost constituent. A related concept is proposed in Jacobs (2001): *semantic subjecthood* is one dimension in Jacobs' multidimensional conception of topichood. According to Jacobs, the semantic subject of a clause is the highest term that specifies a variable in the meaning of the clause's main predicate. As a consequence of the syntax-semantics interface, a sentence-initial constituent will frequently (but not always) contribute the semantic subject to the clause's logical form.

I will adopt Jacobs' idea of theme³ as a configurational notion in logical form and even generalize it to the case where a predicate itself is topical in the sense under discussion.

Overall, then, the architecture that is developed in this paper, consists on the one hand of the information structural triad *background-focus-(contrastive) topic* and on the other hand of the notion of *theme*. I believe that these two dimensions of information structure have different functions in the system of choices that a natural language grammar represents. This is stated in the following hypothesis.

Hypothesis

Syntactic non-canonicity is strongly associated with the choice of theme. On the other hand, prosody is more concerned with the information structural triad of background-focus-(contrastive)topic.

Of course, elements which appear in syntactically non-canonical positions may also be prosodically prominent, so that the two concepts will often interact. Crucial

³I prefer Halliday's name *theme* to Jacobs' own name *semantic subject* for Jacobs' concept.

evidence for the relevance of the notion *theme* comes from inversion constructions. Birner (1996) has shown that this sentence type serves an information packaging function in the sense of Chafe (1976). The following data show, however, that this function is independent of the triad background-focus-topic and needs to be characterized in some other fashion. In (8), the initial PP is in the background, given the context question:

- (8) a. Witness, when you walked into the office, what was on the desk?
 b. [_{bg} On the desk was] [_{loc} a KNIFE].

It is also possible for the inverted PP to be a contrastive topic:

- (9) a. Witness, you told us that was on the shelf, but what was on the desk?
 b. [_{top} On the DESK] [_{bg} was] [_{loc} a KNIFE].

And, finally, inversion sentences can be all-focus, as is shown by (10):

- (10) a. Witness, when you walked into the office, what did you see?
 b. [_{loc} On the desk was a KNIFE].

Discourses like the last one thus show that the preverbal and the postverbal constituents of inversion sentences can be in focus at the same time. Yet, even those sentences are felt to be more about the meaning of the initial PP than the meaning of the final NP. I would like to argue that what underlies this intuition is that inversion sentences are characterized by the following combination of information structural constraints:

- (11) 1. The preverbal constituent of an inversion is the theme (in Jacobs' sense).
 2. The postverbal constituent of an inversion is part of the focus.

Furthermore, I postulate the following preference principles (which could be seen in terms of harmonic alignment in Optimality Theory):

- (12) 1. Preferably, themes are unfocused.
 2. Preferably, themes are discourse-familiar.

This combination of assumptions derives the observation in Birner (1996) that the initial constituent in inversions prefers to be discourse-familiar over being discourse-new by a ratio of about 10:1. Assuming that information foci typically are discourse-new, this is compatible with Birner's finding that the ratio for the postverbal NP in inversions is practically the reverse.

We anticipate that it will be useful to have a notion of relative aboutness that is more general than that of a *theme*, e.g. in order to capture the typical information-structural differences between the two objects in the double object construction of English discussed in detail by Bresnan in recent years (e.g. Bresnan et al. (2007)) and the effects typically associated with scrambling in languages like German (e.g. Webelhuth (1992), Haider and Rosengren (1998)). To this end, we define a relation *more thematic than* in terms of logical form configurations, as follows:⁴

⁴The symbol \triangleleft represents the relation that holds between two LF terms iff the first one is a (not necessarily proper) subconstituent of the second one.

(13) Definition of "more thematic than" (\ll)

$\alpha \ll \beta$ in LF $\Lambda =_{df} \exists \gamma \triangleleft \Lambda$ such that

1. $\gamma = \begin{bmatrix} appl \\ \text{FUNC } \beta' \\ \text{ARG } \alpha' \end{bmatrix}$
2. $\alpha \triangleleft \alpha'$
3. $\beta \triangleleft \beta'$

The representation format is heavily influenced by Sailer (2000). (13) then says that an argument and any term it contains is more thematic than the functor that applies to it and any term contained in the functor. Assuming a function-argument structure for ditransitive verbs where the verb semantically combines with its arguments in the order oblique $<$ direct object $<$ subject, this makes the meaning of the subject more thematic than the meanings of both objects and the meaning of the direct object more oblique than the meaning of the oblique object. As the results of Bresnan's studies on the English double object construction referred to above show, these assumptions are in line with the predictions of (12).

The effect of the definition of relative thematicity can be illustrated with an example from inversion:

(14) On the desk was a knife.

For the purposes of illustration, (14) can be given the logical form below,

$$(15) \begin{bmatrix} appl \\ \text{FUNC } \lambda P. \exists y [knife(y) \wedge P(y)] \\ \text{ARG } \lambda x. \iota z [desk(z) \wedge on(x, z)] \end{bmatrix}$$

which predicates of (the extension of) the property of being on the desk that the generalized quantifier *a knife* applies to it. According to (13), this makes the property more thematic than the generalized quantifier which is the desired result considering the discussion in connection with (8)-(10).

4 Sketch of the Formal Architecture

In this section, I will sketch the architecture that embeds the semantic and information structural assumptions introduced above in HPSG data structures.⁵

We begin by describing the structure of the type *local*:

⁵Length limitations on the article make it impossible to describe every detail of the architecture or the analysis. Moreover, as the analysis below does not involve contrastive topics, this will also allow us to simplify and shorten the exposition by ignoring topics in the current paper. These shortcomings will be remedied in a future publication.

5 Examples of contents

The next two structures illustrate the use of the semantic representations that were just defined.

$$(19) \text{ Fido}_{bg}: \left[\begin{array}{c} \text{word} \\ \text{SS} \left[\begin{array}{c} \text{LOC} \left[\begin{array}{c} \text{CONT} \left[\begin{array}{c} \text{BG} \left[\begin{array}{c} \text{FVARS } \langle \rangle \\ \text{CORE } f_e \\ \text{FOC } \langle \rangle \end{array} \right] \end{array} \right] \end{array} \right] \end{array} \right] \end{array} \right] \end{array} \right]$$

The word *Fido*, marked as backgrounded, has as the core of the background a constant of type e^6 . The focus list is empty and correspondingly the core does not contain a variable representing the focus which means that the list of focus variables is empty as well.

Next, I illustrate a focused word:

$$(20) \text{ barked}_{foc}: \left[\begin{array}{c} \text{word} \\ \text{SS} \left[\begin{array}{c} \text{LOC} \left[\begin{array}{c} \text{CONT} \left[\begin{array}{c} \text{BG} \left[\begin{array}{c} \text{FVARS } \langle P_{ed} \rangle \\ \text{CORE } P_{ed} \end{array} \right] \\ \text{FOC} \left[\begin{array}{c} \text{abstr} \\ \text{TYPE } ed \\ \text{LAM } x_e \\ \text{ARG} \left[\begin{array}{c} \text{drs} \\ \text{UNIV } \langle \rangle \\ \text{CONDS } \langle bark(x_e) \rangle \end{array} \right] \end{array} \right] \end{array} \right] \end{array} \right] \end{array} \right] \end{array} \right] \end{array} \right]$$

I am treating the meaning of *bark* as of type ed , i.e. a function from individuals x into DRSs that contain the condition that x barks. As the word above is focused, this meaning appears as the single member of the word's focus list. The core of the background consists of the variable P of the same type as the focus. As this variable represents the focus, it is bound in FVARS.

6 Semantic composition

This section illustrates the process of the composition of meanings in complex constituents. There are several different cases to consider that are treated with different principles. Recall that the FOC and FVARS lists may both be empty, leaving the CORE as the only obligatory semantic contribution of an expression. In an expression with two subexpressions, the cores must be type compatible with function-argument application, since the core of the mother is the result of applying the core of one daughter to the core of the other. To this end, we make use of a relational constraint *apply* that performs a type check on its two arguments and if possible creates a proper application data structure. As the remaining attributes

⁶Muskens (1996) justifies translating names as constants.

have lists as their values, the values of the lists in the mother are simply the *append* of the corresponding lists in the two daughter constituents:

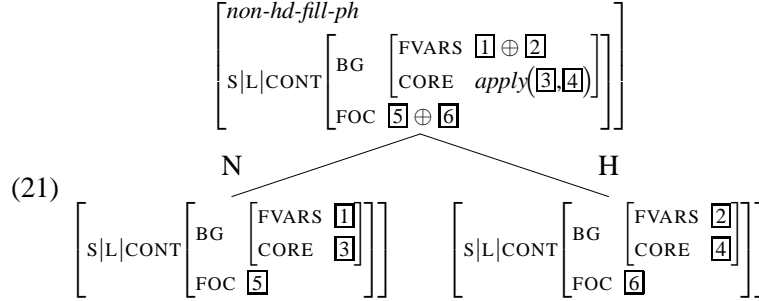

This principle applies only in non-head-filler-phrases. Head-filler phrases need to be treated separately, since they are assumed to contain a gap of the filler which contributes a semantic variable ($\boxed{7}$ below) to its core, the only component of its content which is substantively obligatory. This variable needs to be abstracted over before the meanings of the two core constituents enter into the *apply* relation, to avoid a type incompatibility. This is the only difference between this principle and the previous one, as is shown below:

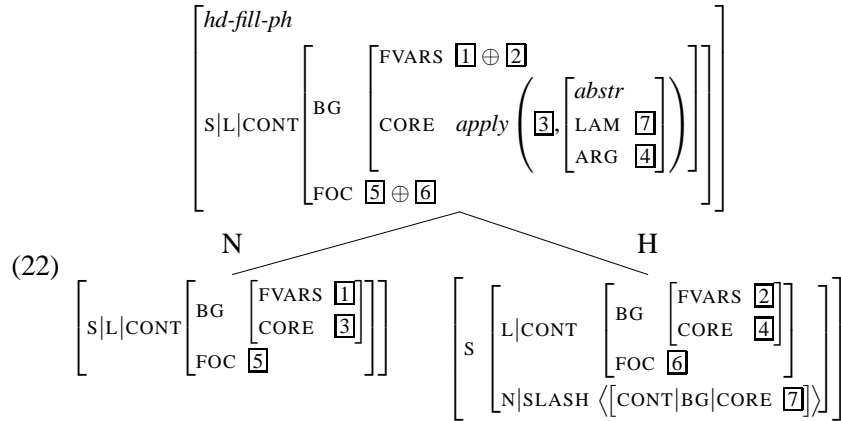

7 Example

We are now in a position to show the effect of combining the meanings of the two lexical entries from section 5, as used in the sentence *Fido_{bg} barked_{foC}*:

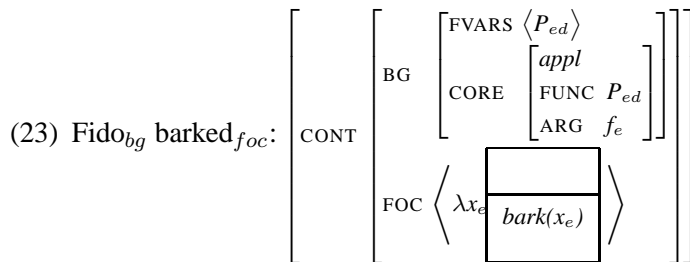

The meaning of the focused word *barked* appears on the focus list of the mother.⁷ The core consists of the application of the two cores of the daughter constituents: the constant f_e contributed by the word *Fido* and the focus variable contributed by *barked*. This focus variable is bound from FVARS.

We can paraphrase this structured meaning informally as follows: the sentence asserts of the set of all properties of Fido that barking is one of them.

8 An Example Involving VP-Preposing

We now return to VP-preposing and its conditions of use. I will analyze the italicized portion of the following example:

(24) I was sure that Fido would bark and *bark he did*

I postulate the following structure for this sentence:

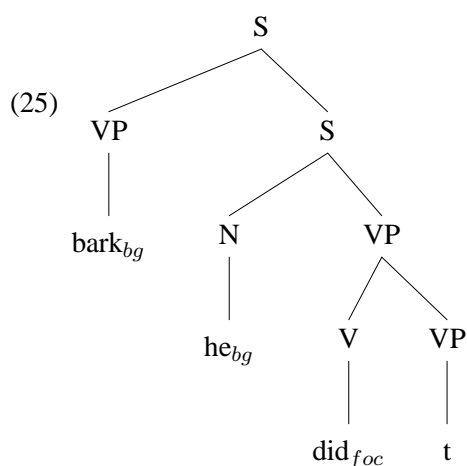

Principles to be introduced later will require that the auxiliary be in focus and the remainder of the sentence in the background.

The semantic composition of this sentence proceeds as follows. The trace of the preposed VP has the following content determined by the lexical entry of the trace: its core consists of a variable of type ed ; the focus and focus variable lists are empty:

$$(26) \text{ t: } \left[\text{CONT} \left[\begin{array}{l} \text{BG} \\ \text{FOC } \langle \rangle \end{array} \left[\begin{array}{l} \text{FVARS } \langle \rangle \\ \text{CORE } Q_{ed} \end{array} \right] \right] \right]$$

Restricting the semantic contribution of a trace to a variable in its core means that the trace in essence remains semantically neutral as far as the structured meaning

⁷We liberally use notational simplifications where this improves readability.

is concerned. Semantic composition can proceed normally and the information structural properties of the filler are in no way predetermined by the status of the trace.

The backgrounded pronoun *he* has empty focus and focus variable lists. Its core consists of a variable as well:⁸

$$(27) \text{ he}_{bg}: \left[\text{CONT} \left[\text{BG} \left[\begin{array}{l} \text{FVARS } \langle \rangle \\ \text{CORE } z_e \end{array} \right] \right] \right]$$

The focused auxiliary is more interesting. We take its ordinary meaning to be the identity function within the semantic domain of type *ed*, i.e. it maps functions from discourse referents to DRSs into themselves. As *did* is focused, this meaning is stored as the single member of the word's focus list. This focus is represented by the variable *R* of type *ed(ed)* in the core and is bound from FVARS:

$$(28) \text{ did}_{foc}: \left[\text{CONT} \left[\text{BG} \left[\begin{array}{l} \text{FVARS } \langle R_{ed(ed)} \rangle \\ \text{CORE } R_{ed(ed)} \end{array} \right] \right] \right]$$

The content of the lower S-node in (25) is the result of a double application: first, the meaning of the auxiliary is applied to the variable contributed by the trace; then, the result is applied to the variable contributed by the subject pronoun:

$$(29) \text{ he}_{bg} \text{ did}_{foc} \text{ t}: \left[\text{CONT} \left[\text{BG} \left[\begin{array}{l} \text{FVARS } \langle R_{ed(ed)} \rangle \\ \text{CORE } \left[\begin{array}{l} \text{appl} \\ \text{FUNC } \left[\begin{array}{l} \text{appl} \\ \text{FUNC } R_{ed(ed)} \\ \text{ARG } Q_{ed} \end{array} \right] \\ \text{ARG } z_e \end{array} \right] \end{array} \right] \right] \right]$$

The top node of (25) is a head-filler phrase. Recall that (22) requires that the variable contributed to the core of the head daughter by the trace is abstracted over before the two daughters of the head-filler-phrase are combined semantically via the apply-relational constraint. We first take care of the abstraction:

⁸The variable will be treated like a discourse referent that must find an accessible antecedent in the previous discourse, according to the standard treatment of pronouns in DRT.

$$(30) \text{ he}_{bg} \text{ did}_{foc} \text{ t: } \left[\begin{array}{c} \text{CONT} \\ \text{BG} \\ \text{CORE} \\ \text{FOC } \langle \lambda P_{ed}.P_{ed} \rangle \end{array} \left[\begin{array}{c} \text{FVARS } \langle R_{ed(ed)} \rangle \\ \text{abstr} \\ \text{LAM } Q_{ed} \\ \text{ARG} \\ \text{FUNC} \\ \text{ARG } z_e \end{array} \left[\begin{array}{c} \text{appl} \\ \text{FUNC } R_{ed(ed)} \\ \text{ARG } Q_{ed} \end{array} \right] \right] \right]$$

The meaning of *bark* is straightforward, as the expression is backgrounded. The focus and focus variable lists are both empty:

$$(31) \text{ bark}_{bg}: \left[\begin{array}{c} \text{CONT} \\ \text{BG} \\ \text{CORE} \\ \text{FOC } \langle \rangle \end{array} \left[\begin{array}{c} \text{FVARS } \langle \rangle \\ \lambda x_e \\ \text{bark}(x_e) \end{array} \right] \right]$$

Finally, we combine (30) and (31) via (22) to arrive at the meaning of the top node of our example sentence:

$$(32) \text{ bark}_{bg} \text{ he}_{bg} \text{ did}_{foc} \text{ t: } \left[\begin{array}{c} \text{CONT} \\ \text{BG} \\ \text{CORE} \\ \text{FOC } \langle \lambda P_{ed}.P_{ed} \rangle \end{array} \left[\begin{array}{c} \text{FVARS } \langle R_{ed(ed)} \rangle \\ \text{appl} \\ \text{abstr} \\ \text{LAM } Q_{ed} \\ \text{ARG} \\ \text{FUNC} \\ \text{ARG } z_e \end{array} \left[\begin{array}{c} \text{appl} \\ \text{FUNC } R_{ed(ed)} \\ \text{ARG } Q_{ed} \end{array} \right] \right] \left[\begin{array}{c} \text{ARG} \\ \lambda x_e \\ \text{bark}(x_e) \end{array} \right] \right]$$

Note that the focus and focus variables stored in the content of the head daughter have been carried up correctly to the corresponding lists of the head-filler phrase. Informally, we can characterize the resulting content as follows: the sentence asserts of the set of relations that hold between the property of barking and the denotation of the subject pronoun *he* that this set contains the relation that holds between a property and an individual if and only if the property applies to the referent. Or, more colloquially: against the background of the issue of which relations hold between barking and the referent of *he* the sentence asserts that barking is one of the properties of that referent.

9 Deriving the Distribution of the Bg and Foc properties

(25) assumes that the preposed VP and the subject of (24) are backgrounded and that the auxiliary *did* is focused. This does not follow from anything we have said so far and still needs to be derived. To this end, we impose appropriate lexical and constructional constraints on predicate preposing constructions. We assume that these constraints are part of the speaker-hearer’s knowledge of the use of this language-particular construction.⁹

The first constraint we need applies to auxiliary words whose second argument is a *gap-synsem*. This singles out auxiliaries whose predicate complement has been preposed. The constraint requires two things: (i) the auxiliary’s value of the attribute STATUS is *focus* and (ii) the status of its first argument (its subject) is *background*:¹⁰

$$(33) \left[\begin{array}{l} \text{aux-wd} \\ \text{ARG-S } \langle \text{NP}, \text{gap-ss} \rangle \end{array} \right] \Rightarrow \left[\begin{array}{l} \text{SS|STATUS } \textit{foc} \\ \text{ARG-S } \quad \langle [\text{STATUS } \textit{bg}], \text{gap-ss} \rangle \end{array} \right]$$

A second principle applies to predicate preposing phrases and requires of their filler daughter that its status be *background*:

$$(34) [\textit{pred-prepos-ph}] \Rightarrow \left[\begin{array}{l} \textit{hd-fill-ph} \\ \text{NON-HD-DTR } [\text{SS|STATUS } \textit{bg}] \end{array} \right]$$

These two constraints will only yield the intended effect if it is guaranteed that the auxiliaries constrained by (33) occur in a predicate preposing phrase and vice versa. In other words, we must make sure that the pieces that make up the predicate preposing construction all occur with each other.

To achieve this, we need to add information to (33) and (34). We introduce a feature CONSTRUCTION (CX) that is borne by the pieces of a construction that may be realized discontinuously.¹¹ We now modify (33) by requiring that the auxiliary find the constructional feature *pred-prepos-cx*. This feature will “float” up the tree until it is bound by an instance of the predicate preposing construction:

$$(35) \left[\begin{array}{l} \text{aux-wd} \\ \text{ARG-S } \langle \text{NP}, \text{gap-ss} \rangle \end{array} \right] \Rightarrow \left[\begin{array}{l} \text{SS|STATUS } \textit{foc} \\ \text{ARG-S } \quad \langle [\text{STATUS } \textit{bg}], \text{gap-ss} \rangle \\ \text{CX} \quad \left[\begin{array}{l} \textit{cx} \\ \text{FIND } \langle \textit{pred-prepos-cx} \rangle \circ L \end{array} \right] \end{array} \right]$$

⁹The assumption that we are dealing with a language-particular construction is motivated in light of the fact that German and English sentences with preposed predicates have different usage conditions.

¹⁰The feature STATUS is appropriate for *synsem* objects and encodes the information structure status of a *synsem*.

¹¹In (24), the auxiliary whose predicate has been preposed is the head of the predicate preposing phrase. But there are examples where this is not the case: *I was afraid that Fido would bark and bark he may have*. The CX-feature functions in some ways like the COLL-feature of Sailer (2000).

Of course, auxiliaries whose predicate complement stays in situ do not float the *pred-prepos-cx* find-feature:

$$(36) \left[\begin{array}{c} \text{aux-wd} \\ \text{ARG-S } \langle NP, \text{ canon-ss} \rangle \end{array} \right] \Rightarrow \left[\text{CX} \left[\begin{array}{c} \text{cx} \\ \text{FIND } L \end{array} \right] \right] \\ \wedge \text{pred-prepos-cx} \notin L.$$

Predicate preposing phrases, in turn, are required to have a head daughter that is looking for a predicate preposing phrase. Moreover, they bind off the feature *pred-prepos-cx*, as expected:

$$(37) [pred-prepos-ph] \Rightarrow \left[\begin{array}{c} \text{hd-fill-ph} \\ \text{HD-DTR} \left[\text{CX} \left[\begin{array}{c} \text{cx} \\ \text{FIND } \langle pred-prepos-cx \rangle \circ L \end{array} \right] \right] \\ \text{CX} \left[\begin{array}{c} \text{cx} \\ \text{FOUND } \langle pred-prepos-cx \rangle \end{array} \right] \end{array} \right]$$

10 Capturing Ward's Generalization

Recall Ward's characterization of the felicity conditions of predicate preposing:

Ward's Generalization Ward (1988)

Predicate preposing is associated with the function of proposition affirmation. Proposition affirmation serves to affirm a proposition explicitly evoked in the discourse.

The semantic representation (32) of (24) does not capture Ward's insight yet. More work is needed to capture the full conditions of use of sentences involving predicate preposing. We begin with the portion of the requirement that predicate preposing must affirm a proposition that has been *explicitly evoked in the discourse*. We will impose a slightly different constraint, namely that the background of the content of predicate preposing phrases must have an antecedent in the discourse that has not been accommodated:

$$(38) [pred-prepos-ph] \Rightarrow \left[\begin{array}{c} \text{CONT|BG} \\ \text{CONX|PRESUPP} \end{array} \left\langle \begin{array}{c} \boxed{\square} \\ \text{ANTEC } \boxed{\square} \\ \text{ACCOM -} \end{array} \right\rangle \circ L \right]$$

Applying this constraint to (32) yields the following representation:

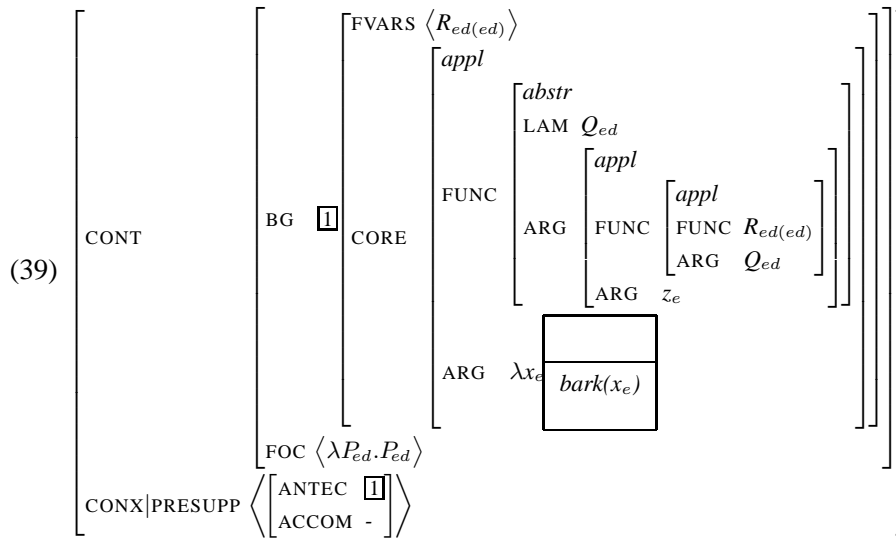

This structure now requires that the issue of which relationships hold between barking and the referent of the subject pronoun *he* must have been introduced into the discourse explicitly and the sentence then asserts that barking indeed *is* a property of that referent.

This leaves the other portion of Ward's Generalization to be derived, the part which says that the sentence must affirm rather than deny the evoked proposition. We will express this constraint as the requirement that the content of the non-head daughter of a predicate preposing phrase must satisfy an *affirmativity constraint* relative to the content of its mother:

$$(40) \left[\begin{array}{c} \text{pred-prepos-ph} \\ \text{S|L|CONT } \boxed{1} \\ \text{NON-HD-DTR } \left[\text{S|L|CONT } \boxed{2} \right] \end{array} \right] \Rightarrow \text{affirmativity-constraint}(\boxed{2}, \boxed{1})$$

The affirmativity constraint does two things: (i) Speaking in a procedural metaphor, it first takes its two arguments (which are structured meanings) and reduces them to single meaningful expressions by recursively applying the background to the list of foci followed by a β -reduction. We assume that this is accomplished by the auxiliary relation called *focus-reduction*. (ii) Secondly, it checks that the focus-reduced content of the non-head daughter does not appear in the scope of negation within the focus-reduced content of the whole phrase:

$$(41) \text{affirmativity-constraint}(\boxed{2}, \boxed{1}) \text{ iff } \text{focus-reduction}(\boxed{2}, \boxed{2}') \wedge \text{focus-reduction}(\boxed{1}, \boxed{1}') \wedge \neg \exists \phi, \psi [\phi \triangleleft \boxed{1}' \wedge \phi \text{ is of the form } \neg \psi \wedge \boxed{2}' \triangleleft \psi]$$

As there is no negation at all in (39), the filler daughter of (25) satisfies the affirmativity constraint and hence Ward's Generalization on predicate preposing.

11 Predictions

The theory of predicate preposing that was developed in the previous sections derives the following correct predictions. (6a) can felicitously be followed by (6b) but not by (6c), since (6c) requires a context which has its background represented without accomodation. Utterances of (6a) do not create such a context. Utterances of (7) do provide the right context for the preposing of the predicate in the second conjunct.

(42b) is not a felicitous response to the question in (42a) since the question requires the preposed predicate of (42b) to be in focus and this contradicts (34):

- (42) a. A: I know that during the spring cleaning Mary washed the windows and Tom cleaned the attic. But what did Jill do?
b. # B: [Wash the FLOORS] she did!

(43) below imposes an unresolvable conflict on the subject pronoun *she* of the response: the contrastive intent of the utterance requires the pronoun to be focused while the preposing construction's auxiliary constraint in (35) forces the subject to be backgrounded:

- (43) a. A: I know that during the spring cleaning Mary washed the windows and Tom cleaned the attic.
b. # B: Actually, [clean the attic] SHE did!

12 Summary

Based on Krifka (1992) and de Kuthy (2000), we have developed an architecture for complex topic-comment structures in HPSG and have applied it to predicate fronting in English with the goal of capturing the insights of Ward (1988) on this construction. We argued that predicate fronting is a distributed constructional form consisting of an auxiliary occurring in a predicate preposing phrase. The use of predicate preposing is a function of a combination of simultaneous constraints on its theme structure, its background-focus distribution, and its presuppositional structure. It was shown that these constraints can be made explicit within the HPSG architecture developed here. Future work will have to show whether the type of analysis of this paper scales up to other non-canonical constructions in English and other languages.

References

- Birner, Betty J. 1996. *The Discourse Function of Inversion in English*. New York: Garland Publishing.
- Bresnan, Joan, Cueni, Anna, Nikitina, Tatiana and Baayen, Harald. 2007. Predicting the Dative Alternation. In I. Kraemer G. Boume and J. Zwarts (eds.),

- Cognitive Foundations of Interpretation*, pages 69–94, Amsterdam: Royal Netherlands Academy of Science.
- Büring, Daniel. 1997. *The Meaning of Topic and Focus—The 59th Street Bridge Accent*. Routledge.
- Chafe, Wallace. 1976. Givenness, Contrastiveness, Definiteness, Subjects, Topics, and Point of View. In *Subject and Topic*, pages 27–55, Charles Li.
- de Kuthy, Kordula. 2000. *Discontinuous NPs in German. A Case Study of the Interaction of Syntax, Semantics, and Pragmatics*. Doktor der philosophie, Universität des Saarlandes, Saarbrücken.
- Haider, Hubert and Rosengren, Inger. 1998. Scrambling. *Sprache und Pragmatik* 49.
- Halliday, M. A. K. 1967. Notes on Transitivity and Theme in English: Part 1. *Journal of Linguistics* 3, 37–81.
- Höhle, Tilman N. 1982. Explikation für "normale Betonung" und "normale Wortstellung". In Werner Abraham (ed.), *Satzglieder im Deutschen—Vorschläge zur syntaktischen, semantischen und pragmatischen Fundierung*, pages 75–153, Tübingen: Gunter Narr Verlag.
- Höhle, Tilman N. 1992. Über Verum-Fokus im Deutschen. In Joachim Jacobs (ed.), *Informationsstruktur und Grammatik*, Linguistische Berichte, pages 112–141, Opladen: Westdeutscher Verlag.
- Jacobs, Joachim. 2001. The dimensions of topic-comment. *Linguistics* 39(4), 641–681.
- Kamp, Hans and Reyle, Uwe. 1993. *From Discourse to Logic*. Dordrecht: Kluwer Academic Publishers.
- Krifka, Manfred. 1992. A compositional semantics for multiple focus constructions. *Linguistische Berichte* 4, 17–53.
- Muskens, Reinhard. 1996. Combining Montague Semantics and Discourse Representation Theory. *Linguistics and Philosophy* 19(2), 143–186.
- Sailer, Manfred. 2000. *Combinatorial Semantics and Idiomatic Expressions in Head-Driven Phrase Structure Grammar*. Ph.D.thesis, Eberhard-Karls-Universität Tübingen.
- Vallduvi, Enric. 1992. *The Informational Component*. New York: Garland.
- Ward, Gregory. 1988. *The Semantics and Pragmatics of Preposing*. New York: Garland.
- Webelhuth, Gert. 1992. *Principles and Parameters of Syntactic Saturation*. Oxford: Oxford University Press.