

French Predicative Verbless Utterances

Frédéric Laurens

frederic.laurens@linguist.jussieu.fr

LLF, Université Paris 7

Proceedings of the HPSG08 Conference

NICT, Keihanna, Japan

Stefan Müller (Editor)

2008

CSLI Publications

<http://csli-publications.stanford.edu/>

## Abstract

This paper focuses on a specific type of verbless utterance, labeled PVU, which is defined by two properties:

- PVUs are not discourse fragments.
- PVUs can host a phrase in their right periphery which is coreferential with their external argument. This phrase is labeled  $\alpha$ -phrase.

PVUs are analyzed as clausal predicative phrases. Although PVUs can have various illocutionary forces, their content type is constrained by their syntactic form. As for  $\alpha$ -phrases, they are shown to be right-dislocated phrases. Right-dislocation is analyzed as a local anaphoric phenomenon. This approach is consistent with the anaphoric properties of PVUs' external arguments.

## 1 Introduction

French verbless utterances fall into at least three categories.<sup>1</sup> *Discourse fragments* form the first category. They convey a clausal meaning. However, this meaning is highly context-dependent. To resolve the meaning of a discourse fragment, it is necessary both to infer the exact type of the fragment and to recover the missing material, which is provided either by an explicit antecedent or by the situational context (Fernández et al. 2007). Short queries are a subtype of discourse fragment (1).

- (1) A- Marie est venue. B- Quand?  
A- Mary has come. B- When?

*Existential verbless utterances* make up the second category. They consist in a noun phrase and behave like autonomous presentative constructions. Examples with various illocutionary forces are given in (2).

- (2) a. Plus d' argent. [context: after opening one's wallet]  
no.more of money  
No more money.
- b. Quoi de plus formateur que ça?  
what of more challenging than that  
What is more challenging than that?
- c. Que de gens ici!  
how.much of people here  
How many people there are here!

---

<sup>†</sup>I thank Jean-Marie Marandin, Anne Abeillé, Olivier Bonami, Danièle Godard, François Mouret and Grégoire Winterstein for their comments.

<sup>1</sup>This picture is somewhat simplified. Adverbs, interjections as well as some verbless idioms are intentionally left aside here (see Laurens 2007).

*Predicative verbless utterances* form the third category (3). PVUs differ from existential verbless utterances in that only the former have an unrealized external argument which can be made explicit by a phrase appearing in their right periphery (3b). I label such phrases  $\alpha$ -phrases for now.

- (3) a. Très jolie voiture!  
           very nice car
- b. Très jolie voiture, [celle de Marie] $_{\alpha}$ !  
           very nice car     [that of Mary]

This paper proposes an analysis of PVUs. In the first section, PVUs are shown to be made up of one predicative phrase with clausal properties. The second section focuses on the properties of  $\alpha$ -phrases. These are shown to be right-dislocated phrases. An analysis of right-dislocation is subsequently proposed. The analysis is then couched in a constructional version of HPSG.

## 2 Analysis of PVUs

PVUs are verbless utterances which are not discourse fragments and are compatible with  $\alpha$ -phrases. They are constituted of a predicative phrase and display clausal properties.

### 2.1 A predicative construction

PVUs are made up of one predicative phrase. It can be either an AP (4a), a NP (4b) or a PP (4c).

- (4) a. [Très sympathique] $_{AP}$ , ton frère.  
           [very nice]                     your brother
- b. [Bon danseur] $_{NP}$ , ton frère.  
           [good dancer]                 your brother
- c. [Encore en retard] $_{PP}$ , ton frère.  
           [again PREP late]             your brother

Adverbial phrases, which are not predicative, are excluded (5).

- (5) \* [Très rapidement] $_{AdvP}$  que l' affaire a été résolue  
       [very quickly]                     that the matter has been solved

Non-predicative APs do not constitute well-formed PVUs (6).

- (6) a. \* La place est assise  
           the ticket is seated

- b. \* Assise, cette place  
seated this ticket

Quantifiers like "tous" (all) ou "chacun" (each) can appear at the beginning of PVUs (7).

- (7) a. Tous très sympathiques, tes amis.  
all very nice your friends
- b. Chacun dans leur monde, tes amis.  
each in their world your friends

Those quantifiers must be analyzed as floating quantifiers rather than subjects of a non-verbal predicate. This is shown by the fact that quantifiers which do not qualify as floating quantifiers do not appear in that position (8).

- (8) \* Beaucoup très sympathiques, tes amis  
many very nice your friends

Moreover, light adverbs such as "encore" (again) cannot be incidental adverbs in preverbal position (Abeillé and Godard 2001). They can however precede initial quantifiers in PVUs as they can precede floating quantifiers in verbal clauses (9).

- (9) a. \* Encore tous sont en retard, tes amis  
again all are PREP late your friends
- b. Encore tous en retard, tes amis.  
again all PREP late your friends

Finally, those quantifiers can also be linearized elsewhere within PVUs (10).

- (10) En retard, tous, tes amis.  
PREP late all your friends.

Interestingly, nouns with an adnominal modifier preferably appear without an indefinite determiner in PVUs (11a) while the indefinite determiner is obligatory when the same predicative noun phrase function as the complement of a verb (11b). The indefinite determiner is also preferably missing in predicative adjuncts (11c).

- (11) a. Très bonne idée, d' avoir apporté du café.  
Very good idea to have brought some coffee
- b. C' est \*(une) très bonne idée, d' avoir apporté du café.  
This is \*(a) very good idea to have brought some coffee
- c. Très bonne idée, le projet a néanmoins été refusé.  
Very good idea the projet has however been rejected

Nevertheless, the indefinite determiner may appear in PVUs (12a) and in predicative adjuncts (12b).

- (12) a. ? Une très bonne idée, d' avoir apporté du café.  
A very good idea to have brought some coffee
- b. ?? Une très bonne idée, le projet a néanmoins été refusé.  
A very good idea the projet has however been rejected

Note that this phenomenon is not related to the constraints on bare predicative nominal complements in French which must belong to specific noun classes such as capacity nouns (De Swart et al. 2007).

It may be conjectured that the mandatory presence of the determiner when the predicative noun phrase is the complement of a verb is not triggered by a constraint on predicative noun phrases but rather by a constraint on nominal complements. Thus, the optionality of the determiner in both constructions may support an analysis of determiners as markers or functors rather than subcategorized dependents of the nominal head (see Van Eynde 2003).<sup>2</sup>

## 2.2 Clause type properties

It has been observed by Marandin (in prep) that declarative clauses are unmarked in French while verbal clauses of other types (exclamative, imperative and interrogative clauses) feature an item which crucially contributes to the construal of their type of content (a parameter for interrogatives, a degree quantifier for exclamatives). This can be observed in PVUs as well.

Selectional properties of verbs have been used to test the semantic content of clauses (Grimshaw 1979, Ginzburg and Sag 2001). However, this can be done only partially for PVUs because some of them never function as the complement of a verb. However, it has been noted by (Beysade and Marandin 2006) that illocutionary tags show semantic selectional properties as well (14). This is also true of evaluative adverbs (not shown here).

---

<sup>2</sup>Note that when no adnominal modifier is present an indefinite modifier is required. This is also the case with some prenominal modifier such a "vrai" (true) (13).

- (13) a. Une (vraie) catastrophe, qu' il soit malade.  
a (true) disaster that he is sick
- b. ?? Vraie catastrophe, qu' il soit malade  
true disaster that he is sick
- c. ?? Catastrophe, qu' il soit malade  
disaster that he is sick

Tags	Felicitous with	Resulting type of call-on-addressee
sans indiscretion <i>just for information</i>	declarative clauses interrogative clauses	question
(14) n'est-ce pas <i>isn't it so</i>	declarative clauses exclamative clauses	question
oui ou non <i>yes or no</i>	declarative clauses polar interrogative clauses	question
point barre <i>period</i>	declarative clauses imperative clauses	assertion outcome

Testing which PVUs can be combined with each of these items, three patterns can be observed. These patterns correlate, as expected, with the presence of specific items within the PVU. PVUs containing an interrogative wh-word behave like interrogative clauses (15).

- (15) a. Sans indiscretion, à quelle heure, le prochain train?  
without indiscretion at what time the next train
- b. # A quelle heure, le prochain train, n'est-ce pas?  
at what time the next train NE-is-this not
- c. # A quelle heure, le prochain train, oui ou non?  
at what time the next train yes or no
- d. # A quelle heure, le prochain train, point barre!  
at what time the next train dot bar

PVUs containing exclamative wh-words behave like exclamative clauses (16).

- (16) a. # Sans indiscretion, quel dommage, qu'il ne vienne pas?  
without indiscretion what.a waste that he-NE-comes not
- b. Quel dommage, qu'il ne vienne pas, n'est-ce pas?  
what.a waste that he-NE-comes not NE-is-this not
- c. # Quel dommage, qu'il ne vienne pas, oui ou non?  
what.a waste that he-NE-comes not yes or no
- d. # Quel dommage, qu'il ne vienne pas, point barre!  
what.a waste that he-NE-comes not dot bar

Other PVUs, which do not contain any of the items cited above, behave like declarative clauses (17).

- (17) a. Sans indiscretion, encore en retard, ton frère?  
without indiscretion again PREP late your brother
- b. Encore en retard, ton frère, n'est-ce pas?  
again PREP late your brother NE-is-this not

- c. Encore en retard, ton frère, oui ou non?  
again PREP late your brother yes or no
- d. Toujours en retard, ton frère, point barre!  
always PREP late your brother dot bar

There are no PVUs of the imperative type although there are declarative PVUs used with a directive value (as there are declarative clauses used with such a value).

- (18) a. Sans indiscretion, bleu le steak?  
without indiscretion rare the steak
- b. Bleu le steak, n'est-ce pas?  
rare the steak NE-is-this not
- c. Bleu, le steak, oui ou non?  
rare the steak yes or no
- d. Bleu, le steak, point barre!  
rare the steak dot bar

### 2.3 Clause properties

PVUs can be coordinated with verbal clauses (19). This is expected if they have a clausal content type themselves.

- (19) a. Très joli tableau mais il est déjà vendu.  
Very nice picture but it is already sold.
- b. Une catastrophe, cette crise ou est-ce une chance pour l' économie?  
A disaster this crisis or is.it a chance for the economy?
- c. Un vrai génie, ce type ou y'a-t-il beaucoup de bruit pour rien.  
A true genius this guy or is.there much of fuzz for nothing

The predicative construction underlying PVUs can be complement clauses when it is interrogative (20a) or exclamative (20b). This is however not the case when it is declarative (20c). This is expected since the complementizer "que" (that) requires a finite complement.

- (20) a. Je me-demande à quelle heure, le prochain train  
I wonder at what time the next train
- b. Regarde quelle belle fleur, cette rose  
Look what.a nice flower that rose
- c. \* Je pense (qu') encore en retard, son frère  
I think that again in delay your brother

Crucially, the relational content of PVUs is contributed by the predicative phrase and need not be inferred from the context or from the content of a discourse antecedent.

### 3 Analysis of $\alpha$ -phrases

One of the two defining properties of PVUs is that they license  $\alpha$ -phrases.  $\alpha$ -phrases are in turn defined by the two following properties. First, they appear in the right periphery of verbless utterances. Then, they are coreferential with the external argument of the verbless utterance's head.

Lefeuve 1999 analyses  $\alpha$ -phrases as subject phrases. However,  $\alpha$ -phrases do not exhibit the same properties as French pre- or postverbal subject phrases. In this section,  $\alpha$ -phrases are shown to be right-dislocated phrases.

#### 3.1 Properties setting $\alpha$ -phrases apart from subject phrases

$\alpha$ -phrases display at least four properties that set them apart from pre- or postverbal subject phrases (see Bonami et al. 1999).

##### 3.1.1 Optionality of $\alpha$ -phrases

In French, a subject phrase must be realized (21a, 21c), unless the external argument of the finite verb is realized by a pronominal affix (21b).

- (21) a. Où va [Marie]<sub>SUBJ</sub>?  
where goes Mary  
Where does Mary go?
- b. Où (Marie) va-t-elle?  
where (Mary) goes-she  
Where does she/Mary go?
- c. \*Où va  
where goes  
*intended: Where does she go?*

By contrast, the realization of an  $\alpha$ -phrase within a PVU is always optional (22), just as right-dislocated phrases are (23).

- (22) Très drôle, ([ton histoire] <sub>$\alpha$</sub> ).  
very funny ([your story])
- (23) Elle est très drôle, ([ton histoire]<sub>RD</sub>).  
it is very funny ([your story])

### 3.1.2 Agreement properties of subjects

The type of agreement observed between subject phrases and non-verbal predicative complements differs from that which is observed between  $\alpha$ -phrases and non-verbal predicates.

$\alpha$ -phrases can display an index-type agreement of the kind in (24) with non-verbal predicates.

- (24) Très beau, [toutes ces décorations] <sub>$\alpha$</sub> .  
very nice.MSG [all these ornaments].FSG

The same kind of agreement can be observed with right-dislocated phrases when the pronominal expression is "ce" or "ça" (this) (25).

- (25) C' est très beau, [toutes ces décorations]<sub>RD</sub>.  
this is very nice.MSG [all these ornaments].FSG

This kind of index-type agreement is ungrammatical between subject phrases and predicative complements (26).

- (26) a. \* [Toutes ces décorations]<sub>SUBJ</sub> est/sont très beau.  
[all these ornaments].FPL is/are very nice.MSG.  
b. [Toutes ces décorations]<sub>SUBJ</sub> sont très belles.  
[all these ornaments].FPL is/are very nice.FPL.

### 3.1.3 Restrictions on subject phrases

French pre- or postverbal subject phrases are submitted to syntactic restrictions. These pertain to category or clause type and do not apply to  $\alpha$ -phrases.

French pre- or postverbal subject phrases cannot be prepositional phrases (27).

- (27) a. \* [Sous ce lit]<sub>SUBJ</sub> est un vrai bordel.<sup>3</sup>  
[under this bed] is a terrible mess  
b. \* Sais-tu comment est [sous ce lit]<sub>SUBJ</sub>  
know-you how is [under this bed]

Prepositional phrases can however be  $\alpha$ -phrases (28) as well as right-dislocated phrases (29).

- (28) Un vrai bordel, [sous ce lit] <sub>$\alpha$</sub> .  
a terrible mess [under this bed]

- (29) C' est un vrai bordel, [sous ce lit]<sub>RD</sub>.  
this is a terrible mess [under this bed]

Exclamative clauses cannot be pre- or postverbal subject phrases in French (30).

- (30) \* [Comme ce moteur tourne vite]<sub>SUBJ</sub> est vraiment étonnant  
[how this engine turns fast] is really incredible

They can however be  $\alpha$ -phrases (31) or right-dislocated phrases (32).

- (31) Vraiment incroyable, [comme ce moteur tourne vite] <sub>$\alpha$</sub> .  
really incredible [how this engine turns fast]

- (32) C' est vraiment incroyable, [comme ce moteur tourne vite]<sub>RD</sub>.  
this is really incredible [how this engine turns fast]

### 3.2 Properties shared by $\alpha$ -phrases and right-dislocated phrases

Not only do  $\alpha$ -phrases display properties that are distinct from those of subject phrases, but they also share specific properties with right-dislocated phrases (see De Cat 2002, Villalba 2000).

#### 3.2.1 Incompatibility with quantified noun phrases

Quantified noun phrases cannot be  $\alpha$ -phrases (33).

- (33) \* Encore en retard, [chaque étudiant qui est venu] <sub>$\alpha$</sub>   
Again PREP late [every student that has come]

This is also true of right-dislocated phrases (34).

- (34) \*Jean le/les recevra, [chaque étudiant qui est venu]<sub>RD</sub>  
John him/them receive.FUT [every student that has come]

Pre- or postverbal subject phrases, on the other hand, do not show this property (35).

- (35) C' est le film qu' a vu [chaque étudiant qui est venu]<sub>SUBJ</sub>.  
this is the movie that has seen [every student that has come]

#### 3.2.2 Incompatibility with restrictive adverbs like "seulement" (only)

An  $\alpha$ -phrase cannot be a noun phrase containing a restrictive adverb like "seulement" (only) (36).

- (36) \* Encore en retard, [Marie seulement] <sub>$\alpha$</sub>   
Again late [Mary only]

This is also true of dislocated phrases (37).

- (37) \* Elle est encore en retard, [Marie seulement]<sub>RD</sub>  
She is again late [Mary only]

Pre- or postverbal subjects do not have this property (38).

- (38) C' est le film qu' a vu [Marie seulement]<sub>SUBJ</sub>.  
This is the movie that has seen [Mary only]

### 3.2.3 Incompatibility with omnisyndetic coordinations

An  $\alpha$ -phrase cannot be an omnisyndetic coordination (39) (see Mouret 2005).

- (39) \* Plutôt sympathiques, [et Marie et Jean] <sub>$\alpha$</sub>   
Quite nice [both Mary and John]

This is also true of right-dislocated phrases (40).

- (40) \* Ils sont plutôt sympathiques, [et Marie et Jean]<sub>RD</sub>  
They are quite nice [both Mary and John]

Pre- or postverbal subjects do not have this property (41).

- (41) C' est le film qu' ont vu [et Marie et Jean]<sub>SUBJ</sub>.  
This is the movie that have seen [both Mary and John]

### 3.2.4 $\alpha$ -phrases and associative anaphora

Right-dislocation usually involves coreference. Less frequently, it may resort to associative anaphora (42a). This is also the case with left-dislocation (42b).

- (42) a. J'adore la couleur du bois, [ta nouvelle chaise]<sub>RD</sub>.  
I love the color of the wood [your new chair].  
b. [Ta nouvelle chaise]<sub>LD</sub>, j'adore la couleur du bois.  
[Your new chair], I love the color of the wood.

Associative anaphora is also found in PVUs (43). Since associative anaphora only holds between noun phrases, it only involves nominal PVUs. In this case, there is no anaphoric link between the right-dislocated phrase and the external argument of the head noun phrase.

- (43) Très beau bois, [ta nouvelle chaise]<sub>RD</sub>.  
Very nice wood [your new chair].

Lefevre 1999 proposes to relate the asymmetry between the properties of  $\alpha$ -phrases and subject phrases to the category of the head phrase (verb vs. non-verb). Such a proposal cannot account for the fact that  $\alpha$ -phrases precisely have the properties of right-dislocated phrases.

### 3.3 Properties of right-dislocation in French

A key syntactic feature of PVUs is that they license a right-dislocated phrase which is coindexed with their external argument. Thus, an analysis of right-dislocation is needed to obtain a full characterization of PVUs.

#### 3.3.1 General properties

Leaving aside associative anaphora, right-dislocated phrases are typically licensed by some anaphoric expression. French anaphoric expressions include pronominal affixes (44a), strong pronouns (44b), possessive determiners or adjectives (44c), nounless noun phrases (44d) and the unrealized argument of imperative verb forms (44e).

- (44) a. Paul lui<sub>i</sub>-a déjà parlé, [à Marie]<sub>RD*i*</sub>.  
Paul him[A]-has already talked [A Mary]
- b. On-m'-a déjà présenté à [lui]<sub>i</sub>, [Paul]<sub>RD*i*</sub>.  
One-me-has already presented A [him] [Paul]
- c. [Son]<sub>i</sub> livre est intéressant, [à Marie]<sub>RD*i*</sub>.  
[His] book is interesting [A Mary]
- d. [Le rouge]<sub>i</sub> est intéressant, [de livre]<sub>RD*i*</sub>.  
[The red] is interesting [DE book]
- e. Entrons, [nous aussi]<sub>RD</sub>.  
Go.in [us too]

Each anaphoric expression can be associated with only one right-dislocated phrase at a time (45).

- (45) \* Quel bel animal, [le sien], [ce chien].  
What nice animal [the hers] [this dog]

Right-dislocated phrases can be licensed by an anaphoric expression which is contained within a right-dislocated phrase (47a, 47b).<sup>4</sup>

- (47) a. Très beau, [son chapeau]<sub>RD</sub>, [à Jean]<sub>RD</sub>.  
very nice [his hat] [A John]
- b. Très belle, [la sienne]<sub>RD</sub>, [de voiture]<sub>RD</sub>.  
very nice, [the hers], [DE car]

---

<sup>4</sup>Associative anaphora is also observed between two right-dislocated phrases (46).

- (46) Très beau, [le bois]<sub>RD</sub>, [ta nouvelle chaise]<sub>RD</sub>.  
very nice, [the wood] [your new chair].

The form of the right-dislocated phrase is constrained by the licensing anaphoric expression (48, 49).

- (48) a. Incroyable, [que Marie soit venue]<sub>RD</sub>.  
 Unbelievable [that Mary is.SBJV come]
- b. \* Incroyable, [que Marie est venue]<sub>RD</sub>  
 Unbelievable [that Mary is.IND come]

- (49) a. Très vrai, [que Marie est venue]<sub>RD</sub>.  
 Very true [that Mary is.IND come]
- b. \* Très vrai, [que Marie soit venue]<sub>RD</sub>  
 Very true, [that Mary is.SBJV come]

Right-dislocated phrases are islands for certain types of extraction (50).

- (50) a. Je-trouve ça<sub>i</sub> incroyable, [que Marie soit venue trois fois]<sub>i</sub>  
 I-find that incredible that Mary is come three times
- b. \*Combien de fois trouves-tu ça<sub>i</sub> incroyable, [que Marie soit venue]<sub>i</sub>  
 How.much of times find-you that incredible that Mary is come

### 3.3.2 Locality

Right-dislocation is more local than left-dislocation. A right-dislocated phrase must always appear within the clause that contains the licensing anaphoric expression (Right Roof Constraint). This is shown by the contrast between (51a) and (51b).

- (51) a. L' homme [qui lui<sub>i</sub>-a parlé, [à Marie]<sub>i</sub>], est venu.  
 The man [who her[A]<sub>i</sub>-has talked [A Mary]<sub>i</sub>] is come
- b. \* L' homme [qui lui<sub>i</sub>-a parlé] est venu, [à Marie]<sub>i</sub>.  
 The man [who her[A]<sub>i</sub>-has talked] is come [A Mary]<sub>i</sub>

In fact, right-dislocated phrases bind the anaphoric expression that licenses them in their clausal domain.

### 3.3.3 Properties of the coindexation

No other phrase can be coindexed with an anaphoric expression bound by a right-dislocated phrase.<sup>5</sup> This can be shown in contexts where coreference between two expressions can only be established using a pronominal expression as in (52a).

<sup>5</sup>This is also true of left-dislocated phrases.

- (52) a. Ils<sub>i</sub> voulaient que Paul leur<sub>i</sub> lise des histoires.  
 They<sub>i</sub> wanted Paul to read them<sub>i</sub> stories.
- b. Ils<sub>i</sub> voulaient que Paul lise des histoires [aux enfants]<sub>\*i</sub>.  
 They<sub>i</sub> wanted Paul to read stories [to the children]<sub>\*i</sub>

When the pronoun "leur" is bound by a right-dislocated phrase as in (53), the coindexation between the two pronominal expressions which is grammatical in (52a) becomes ungrammatical.

- (53) Ils<sub>i</sub> voulaient que Paul leur<sub>{\*i,j}</sub> lise des histoires, [aux enfants]<sub>RDj</sub>.  
 They<sub>i</sub> wanted Paul to read them<sub>{\*i,j}</sub> stories, [the children]<sub>RDj</sub>.

Contrastively, the coindexation of the two pronominal expressions is possible if the right-dislocated phrase binds the pronominal expression "ils" because "leur" is not bound by a right-dislocated phrase (54).

- (54) Ils<sub>i</sub> voulaient que Paul leur<sub>i</sub> lise des histoires, les enfants<sub>i</sub>.  
 They wanted that Paul them[A] read some stories the children

We observe the same coindexation constraints for binding as those we have just observed for coreference. It is known that a quantifier can bind a pronominal variable or a nounless noun phrase which is inside a right dislocated phrase (Cecchetto 1999) 55.

- (55) [Chaque homme]<sub>i</sub> en<sub>j</sub> rêve, [des livres qu' il<sub>i</sub> lit]<sub>RDj</sub>.  
 [Every man] them[DE] dreams, [the[DE] books that he reads]

In donkey sentences, the quantifier can bind a pronoun or a nounless NP inside a right-dislocated phrase. In such a configuration, it is observed that bindable right-dislocated phrases (such as nounless noun phrases) are grammatical while non-anaphoric noun phrases are not (56, 57).

- (56) a. A- Les ânes rouges sont toujours malheureux.  
 A- Red donkeys are always unhappy.
- b. B' - Tout homme qui a des ânes<sub>i</sub> colorés bat les rouges<sub>i</sub>.  
 B' - Every man who has colored donkeys beats the red ones.
- c. B'' - Tout homme qui a des ânes<sub>i</sub> colorés les<sub>i</sub> bat, [les rouges]<sub>i</sub>.  
 B'' - Every man who has colored donkeys beats them, [the red ones].
- (57) a. A- Les ânes sont toujours malheureux.  
 A- Donkeys are always unhappy.
- b. B' - \*Tout homme qui a des ânes<sub>i</sub> colorés bat les ânes<sub>i</sub>.  
 B' - Every man who has colored donkeys beats the donkeys.

- c. B''- \*Tout homme qui a des ânes<sub>i</sub> colorés les<sub>i</sub> bat, [les ânes]<sub>i</sub>.  
 B''- Every man who has colored donkeys beats them, [the donkeys].

Thus, (56c) is parallel to (55).

The same constraints on anaphoric relations apply in PVUs. This is hard to show because discourse constraints on coreference are weaker than coindexation constraints

within clauses. Consider however the discourse sequences in (58).

- (58) a. Qui est le plus fort? Le nouveau? Très intelligent en effet.  
 Who is the best? The new guy? Very intelligent indeed.
- b. Qui est le plus fort? [Le nouveau]<sub>i</sub>? Très intelligent en effet, Jean<sub>i</sub>.  
 Who is the best? [The new guy]? Very intelligent indeed, John.
- c. #Qui est le plus fort? [Le nouveau]<sub>i</sub>? Très intelligent en effet, Jean<sub>j</sub>.  
 Who is the best? [The new guy]? Very intelligent indeed, John.

The short query "the new guy?" makes explicit a biased answer to the preceding question. The following PVU is then interpreted as a comment on "the new guy" which is the expected answer to the question (58a). If there is a right-dislocated phrase in the PVU, it must be interpreted as coreferent with "the new guy" as in (58b). Else, the discourse sequence is not well-formed (58c).

## 4 HPSG analysis

The HPSG analysis presented here builds upon the constructional analysis of clause types proposed by Ginzburg and Sag 2001. PVUs are integrated in a modified hierarchy of French phrasal types. PVUs being predicative phrases, an HPSG analysis of predicative lexemes and words is also provided. Finally, an HPSG account of right-dislocation is introduced.

### 4.1 Predicative lexemes and words

Predicative lexemes, including verbs, are defined as lexemes with a distinguished element on their argument structure list. The recording of the special status of this element which corresponds to the external argument of the lexeme is achieved using a list-valued head feature (XARG) (59) (see Sag 2007). A definition of non-predicative lexemes is given in (60) for comparison.

$$(59) \text{ predicative-lexeme} \Rightarrow \left[ \begin{array}{l} \text{HEAD} \quad \left[ \text{XARG} \quad \langle \boxed{1} \rangle \right] \\ \text{ST-ARG} \quad \langle \boxed{1} \rangle \oplus \boxed{A} \end{array} \right]$$

$$(60) \text{ non-predicative-lexeme} \Rightarrow \left[ \begin{array}{l} \text{HEAD} \quad \left[ \text{XARG} \quad \langle \rangle \right] \\ \text{ST-ARG} \quad \text{list}(\text{synsem}) \end{array} \right]$$

The external argument of a predicative lexeme can be realized in more than one fashion. Predicative words can, for example, subcategorize for a subject phrase (61). A null realization of the external argument (62) is also possible as it is the case in PVUs. PVUs are thus subject-saturated.

$$(61) \text{ predicative-word-with-subject} \Rightarrow \left[ \begin{array}{l} \text{HEAD} \quad \left[ \text{XARG} \quad \boxed{1} \right] \\ \text{SUBJ} \quad \langle \boxed{1} \rangle \\ \text{ST-ARG} \quad \langle \boxed{1} \text{ canonical-synsem} \rangle \oplus \boxed{A} \end{array} \right]$$

$$(62) \text{ predicative-word-without-subject} \Rightarrow \left[ \begin{array}{l} \text{HEAD} \quad \left[ \text{XARG} \quad \boxed{1} \right] \\ \text{SUBJ} \quad \langle \rangle \\ \text{ST-ARG} \quad \langle \boxed{1} \text{ pro-synsem} \rangle \oplus \boxed{A} \end{array} \right]$$

## 4.2 Predicative verbless utterances

Construational properties of PVUs are introduced within a hierarchy of phrasal types. The hierarchy in (63) displays three dimensions of classification rather than two as in Ginzburg and Sag 2001. The first dimension, labeled HEADEDNESS, is used to distinguish headed phrases and their subtypes from non-headed phrases. The dimension CONTENT-TYPE is used to distinguish phrases with a clausal content type (message type) from phrases with other content types. Finally, the dimension AUTONOMY distinguishes phrases whose content is context-sensitive like discourse fragments from phrases whose content is not context-sensitive.

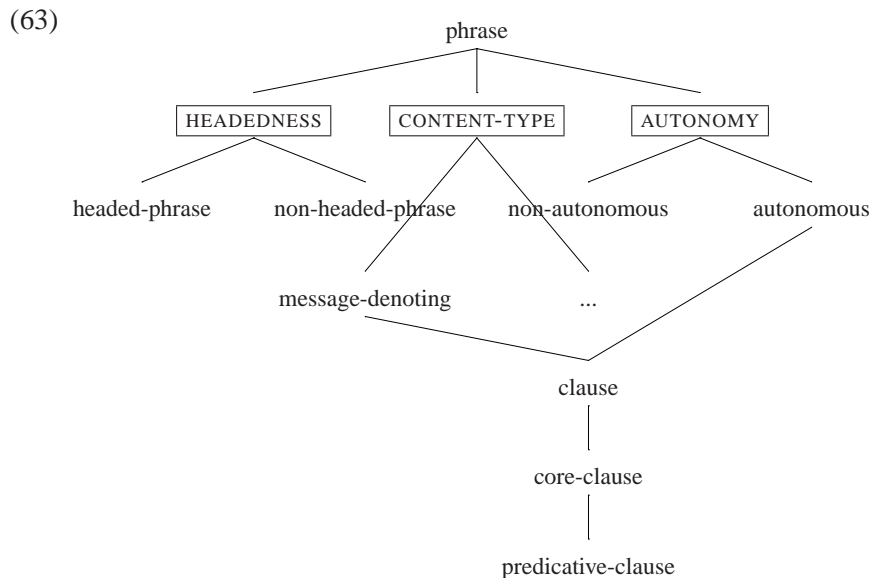

Clauses are defined as a subtype of *message-denoting-phrase* and *autonomous-phrase*. They have an empty SUBJ list (64).

$$(64) \text{ clause} \Rightarrow \text{message-denoting} \ \& \ \text{autonomous} \ \& \ \left[ \text{SUBJ} \langle \rangle \right]$$

As in Ginzburg and Sag 2001, the type *core-clause* stands for any clause which is not a modifier (65).

$$(65) \text{ core-cl} \Rightarrow \text{clause} \ \& \ \left[ \text{MOD} \text{ none} \right]$$

A *predicative-clause* type corresponding to PVUs is introduced. It is a core-clause which cannot be embedded. Its head is non-verbal and predicative. No subject phrase is realized. The content of the clause is contributed by its head daughter (66).

$$(66) \text{ predicative-cl} \Rightarrow \text{core-cl} \ \& \ \left[ \begin{array}{l} \text{IC} \quad + \\ \text{HEAD} \quad \left[ \begin{array}{l} \textit{non-verbal} \\ \text{XARG} \langle \textit{pro-synsem} \rangle \end{array} \right] \\ \text{CONT} \quad \left[ \text{SOA} \left[ \text{NUCL} \left[ \text{MSG-ARG} \left[ \text{2} \right] \right] \right] \right] \\ \text{HD-DTR} \quad \left[ \text{CONT} \left[ \text{2} \right] \right] \end{array} \right]$$

The predicative clause type has three subtypes which have each a distinctive content-type (67).

$$(67) \text{ a. declarative-clause} \Rightarrow \text{core-clause} \ \& \ \left[ \text{CONT} \textit{proposition} \right]$$

$$\text{b. exclamative-clause} \Rightarrow \text{core-clause} \ \& \ \left[ \text{CONT} \textit{exclamation} \right]$$

$$\text{c. interrogative-clause} \Rightarrow \text{core-clause} \ \& \ \left[ \text{CONT} \textit{question} \right]$$

Table (68) displays the three subtypes of PVUs.

	type	inherits from	example
(68)	declarative-predicative-cl	predicative-cl declarative-cl head-only-ph	Encore en retard. He's late again.
	exclamative-predicative-cl	predicative-cl exclamative-cl head-only-ph	Quel dommage! What a pity!
	interrogative-predicative-cl	predicative-cl interrogative-cl head-only-ph	A quelle heure? At what time is it?

### 4.3 Right-dislocation

Right-dislocation involves coindexation between an anaphoric expression and a right-dislocated phrase as well as opacity of the anaphoric expression for other binding relations. It also involves connectivity constraints between the anaphoric expression and the right-dislocated phrase (see examples 48 and 49 above).

There are at least two options for an accurate HPSG account of right-dislocation: either a lexical account which is based on the properties of anaphoric expressions or a constructional approach based on selectional constraints of right-dislocated phrases regarding the kind of anaphoric expressions contained within their host. The former option is chosen here because the binding properties of anaphoric expressions are affected by the presence of a right-dislocated phrase.

#### 4.3.1 Anaphoric expressions

Anaphoric expressions are either free (having a source in the discourse) or bound by a right-dislocated phrase in the clausal domain. Thus, two types of anaphoric expressions reflecting these properties must be defined. Two set-valued context features are introduced: ANTEC which keeps track of the source required by anaphoric expressions and R-DISL which keeps track of right-dislocated phrases licensed by anaphoric expressions. No anaphoric expression can both require a source and license a right-dislocated phrase. This is reflected by the type definitions given in (69) and (70).

$$(69) \quad \text{anaphoric-local-with-source} \Rightarrow \& \text{ local} \& \left[ \text{CTXT} \left[ \begin{array}{l} \text{ANTEC} \{ \textit{index} \} \\ \text{R-DISL} \{ \} \end{array} \right] \right]$$

$$(70) \quad \text{anaphoric-local-with-right-dislocate} \Rightarrow \text{local} \& \left[ \text{CTXT} \left[ \begin{array}{l} \text{ANTEC} \{ \} \\ \text{R-DISL} \{ \textit{local} \} \end{array} \right] \right]$$

An example is given for possessive determiners. The lexical entry in (72) corresponds to the use of the possessive determiner in (71a) while the lexical entry in (72) corresponds to the use of the possessive determiner in (71b).

- (71) a. Marie a lu son livre.  
       Mary has read her/his book
- b. [Son]<sub>i</sub> livre est vraiment pas mal, [à Marie]<sub>i</sub>.  
       [Her] book is really not bad, [A Mary]

$$(72) \quad \text{a.} \left[ \begin{array}{l} \text{CONT} \left[ \text{RELS} \left\{ \left[ \begin{array}{l} \textit{possess-rel} \\ \text{POSSESSOR} \boxed{1} \end{array} \right] \right\} \right] \\ \text{CTXT} \left[ \begin{array}{l} \text{ANTEC} \{ \boxed{1} \} \\ \text{R-DISL} \{ \} \end{array} \right] \end{array} \right]$$

$$b. \left[ \begin{array}{l} \text{CONT} \left[ \text{RELS} \left\{ \left[ \begin{array}{l} \textit{possess-rel} \\ \text{POSSESSOR } \boxed{1} \end{array} \right\} \right] \\ \text{CTXT} \left[ \begin{array}{l} \text{ANTEC } \{ \} \\ \text{R-DISL} \left\{ \left[ \begin{array}{l} \text{MARKING } \grave{a} \\ \text{INDEX } \boxed{1} \textit{ individual} \end{array} \right\} \right] \end{array} \right] \end{array} \right]$$

By default, the R-DISL set of a phrase is the union of the R-DISL sets of its daughters.

### 4.3.2 Head-right-dislocated-phrase

A subtype of headed-phrase (head-right-dislocated-phrase) is posited in order to account for the realization of right-dislocated-phrases. It is composed of a head (the host phrase) and a right-dislocated phrase on the right. While an anaphoric expression only licenses one right-dislocated phrase, the R-DISL set can contain more than one element at the level of a clause if it contains more than one licensing expression. When a right-dislocated phrase is realized, the corresponding element is discharged from the R-DISL set (73).

(73) head-right-dislocated-phrase  $\Rightarrow$  headed-phrase &

$$\left[ \begin{array}{l} \text{CTXT} \left[ \text{R-DISL } \boxed{A} \right] \\ \text{HD-DTR } \boxed{1} \left[ \text{CTXT} \left[ \text{R-DISL } \left\{ \boxed{2} \right\} \cup \boxed{A} \right] \right] \\ \text{DTRS} \left\langle \boxed{1}, \left[ \text{SYNSEM} \left[ \text{LOCAL } \boxed{2} \right] \right] \right\rangle \end{array} \right]$$

The locality constraint on right-dislocation is enforced by (74). Within a phrase, every clause which is not a head must have an empty R-DISL set. Root clauses must also have an empty R-DISL set (not shown here).

$$(74) \left[ \text{NHD-DTRS contains} \left( \boxed{A} \textit{ clause} \right) \right] \Rightarrow \left[ \text{NHD-DTRS contains} \left( \boxed{A} \left[ \text{R-DISL } \{ \} \right] \right) \right]$$

## 5 Conclusion

PVUs are root clauses whose head is a non-verbal predicative phrase. They never display a subject phrase but they are nevertheless saturated phrases, their external argument being an anaphoric expression.

It has been shown how to integrate PVUs in a hierarchy of French clause types. They are a subtype of headed-phrase and are autonomous in discourse in the sense

that their relational content need not be inferred from the discourse or situational context. Moreover, they show clause type properties. There are declarative, interrogative and exclamative PVUs.

PVUs are compatible with right-dislocated phrases just like verbal clauses are. A right-dislocated phrase can be licensed by the external argument of the PVU. In that case, the external argument of the PVU is opaque for anaphoric relations but the right-dislocated phrase is not. A head-right-dislocated-phrase has been defined to account for the properties of right-dislocation. It is compatible with verbal or non-verbal heads.

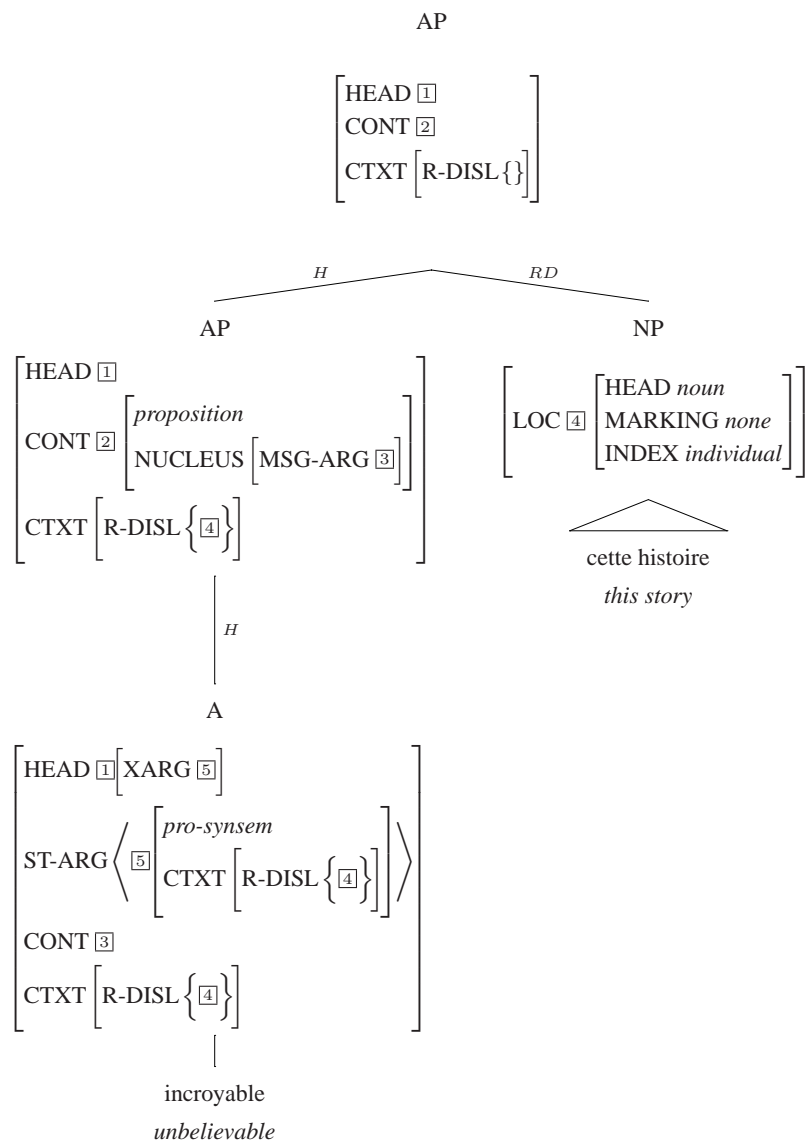

## References

- Abeillé, Anne and Godard, Danièle. 2001. *A class of lite adverbs in French*, pages 9–25. Amsterdam: J. Benjamins.
- Beyssade, Claire and Marandin, Jean-Marie. 2006. From complex to simple speech acts: a bidimensional analysis of illocutionary forces. In *Brandial*, Postdam.
- Bonami, Olivier, Godard, Danièle and Marandin, Jean-Marie. 1999. Constituency and word order in French subject inversion. In *Constraints and Resources in Natural Language Syntax and Semantics*, pages 21–40, Stanford : CSLI Publications.
- Cecchetto, Carlo. 1999. A comparative analysis of left and right dislocation in romance. *Studia Linguistica* 53, 40–67.
- De Cat, Cécile. 2002. *French Dislocation*. Ph. D.thesis, University of York, UK.
- De Swart, Henriette, Winter, Yoad and Zwarts, Joost. 2007. Bare nominals and reference to capacities. *Natural Language and Linguistic Theory* 25.
- Fernández, Raquel, Ginzburg, Jonathan and Lappin, Shalom. 2007. Classifying Non-Sentential Utterances in Dialogue: A Machine Learning Approach. *Comput. Linguist.* 33(3), 397–427.
- Ginzburg, Jonathan and Sag, Ivan A. 2001. *Interrogative Investigations: the form, meaning, and use of English Interrogatives*. Stanford, California: CSLI Publications.
- Grimshaw, Jane. 1979. Complement selection and the lexicon. *Linguistic inquiry* 10(2), 279–326.
- Laurens, Frédéric. 2007. *Analyse et Formalisation des Types de Phrases Averbales du Français*. Masters Thesis, Université Paris Diderot - Paris 7, France.
- Lefevre, Florence. 1999. *La phrase verbale en français*. Paris: L'Harmattan.
- Marandin, Jean-Marie. in prep. les types phrastiques. In Anne Abeillé, Annie Delaveau and Danièle Godard (eds.), *Grande Grammaire du Français*, Bayard Presse.
- Mouret, François. 2005. The Syntax of French Conjunction Doubling. In N. Adam, A. Cooper, F. Parrill and T. Wier (eds.), *Proceedings of the 40th Regional Meeting of the Chicago Linguistic Society*, volume 2.
- Sag, Ivan A. 2007. Remarks on Locality. In Stefan Müller (ed.), *The Proceedings of the 14th International Conference on Head-Driven Phrase Structure Grammar*, pages 394–414, Stanford: CSLI Publications.
- Van Eynde, Frank. 2003. On the Notion ‘Determiner’. In Stefan Müller (ed.), *Proceedings of the HPSG-2003 Conference, Michigan State University, East Lansing*, pages 391–396, Stanford: CSLI Publications.
- Villalba, Xavier. 2000. *The Syntax of Sentence Periphery*. Ph. D.thesis, Universitat Autònoma de Barcelona, Spain.