

The representation of syllable structure in HPSG

Jesse Tseng

Cognition Langues Langage Ergonomie
Équipe de recherche en syntaxe et sémantique
CLLE-ERSS UMR 5263
CNRS & University of Toulouse

Proceedings of the HPSG08 Conference

NICT, Keihanna, Japan

Stefan Müller (Editor)

2008

CSLI Publications

<http://csli-publications.stanford.edu/>

Abstract

This paper proposes a representation for syllable structure in HPSG, building on previous work by Bird and Klein (1994), Höhle (1999), and Crysmann (2002). Instead of mapping segments into a separate part of the sign where syllables are represented structurally, information about syllabification is encoded directly in the list of segments, the core of the PHONOLOGY value. Higher level prosodic phenomena can operate on a more abstract representation of the sequence of syllables derived from the syllabified segments list. The approach is illustrated with analyses of some word-boundary phenomena conditioned by syllable structure in French.

1 Introduction

In Pollard and Sag (1994) the value of the PHONOLOGY attribute is assumed to be a list of unanalyzed phoneme strings corresponding to words or lexemes. It has become common practice to further simplify the PHON value to contain orthographic forms. This convention has arisen because in most HPSG work, the primary function of the PHON value is to encode surface word order, and a simple indication of each word's identity is sufficient for these purposes.

For analyses that need to refer to the phonological properties of words and phrases, this kind of “placeholder” representation is of course inadequate. Given the flexibility of the typed feature structure formalism, however, several different approaches for enriching this part of the HPSG sign can be (and have been) imagined. Recent interest in HPSG phonology has focused on phenomena at the level of the prosodic word and above (Klein, 2001; Bonami and Delais-Roussarie, 2006). At the same time, work in morphophonology and phonosyntax makes reference to the segmental phonology of words (e.g. Bonami et al., 2004). In this paper I will concentrate on the level of syllable structure, and develop a framework for the representation of syllables in HPSG building on insights from existing proposals.

2 Segments

2.1 Segmental features

The smallest phonologically meaningful unit in most theories is the segment. Segments are typically defined as collections of phonological features encoding, for example, voicing, the position and configuration of the various articulators, the manner of articulation. Each feature generally has a predefined set of possible values, and the features are grouped into bundles based on empirical evidence such as covariation in assimilation phenomena. This kind of feature geometry can be straightforwardly encoded in HPSG.

[†]I would like to thank the anonymous reviewers and the participants of HPSG 2008 and Gergana Popova for valuable comments. Special thanks also to Berthold Crysmann.

Bird and Klein (1994), for example, adopt the boolean features of Clements (1985):

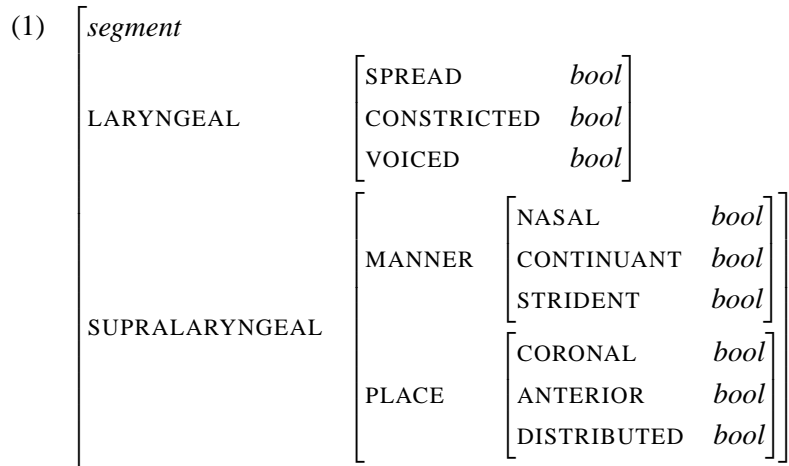

This proposal does not make much use of types. Höhle (1999), in contrast, takes full advantage of this formal notion of HPSG. Part of his signature is reproduced below:¹

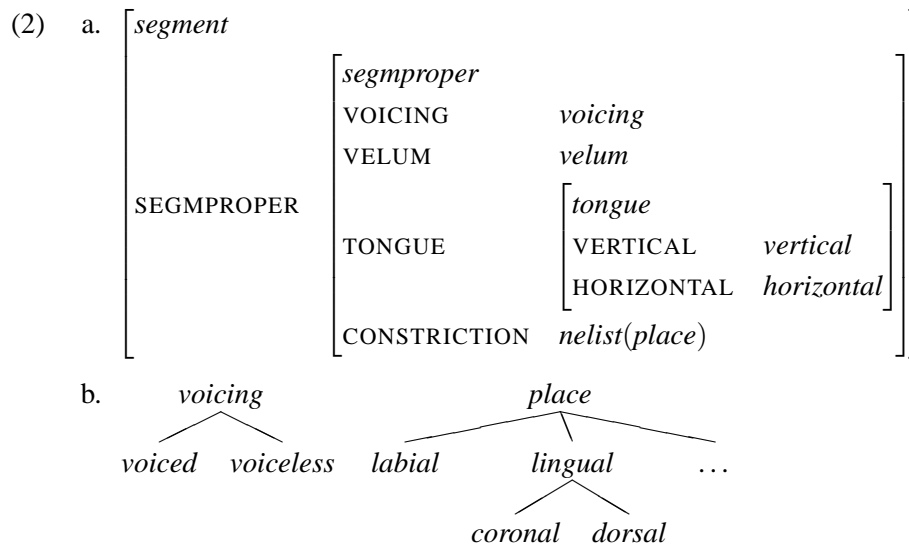

None of these authors seems particularly committed to any specific proposal for segmental representation. Empirical and analytical issues remain open (what distinctions are needed, how they should be encoded). The point is that the HPSG formalism is able to directly accommodate any model within this general approach.

In such models, a segment can be uniquely identified by specifying the corresponding matrix of distinctive features. It is convenient, however, to reify individual segments as named objects in the type hierarchy. Höhle does this by defining

¹The attribute CONSTRUCTION is in fact only appropriate for the *segmproper* subtype *consonant*; see (3) below.

phonemic sorts such as *sort_ɪ*, *sort_y*, *sort_k*, *sort_d*, *sort_n*, etc. Such maximal types are not only useful as abbreviatory devices. They provide a way of explicitly specifying the inventory of segments in a given language (with idiosyncratic gaps and outliers that do not reflect generalizations over phonological features).

These segmental sorts are the leaves of a hierarchy that can be enriched with intermediate types representing natural classes of segments. For Höhle, these are subtypes of *segmproper*, for which he proposes the following hierarchy:

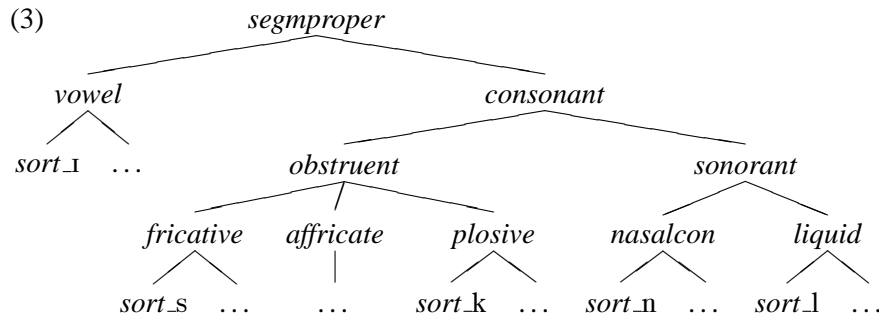

This hierarchy can be extended with further intermediate types, for example, underspecified archiphoneme types that subsume the segmental sorts corresponding to their allophones.

A natural extension is to allow multiple inheritance and introduce other dimensions of variation in the segmental hierarchy. For example, Höhle encodes quantity by introducing *long* and *short* as subtypes of *segment*, but one could also add a QUANTITY dimension directly to the *segmproper* hierarchy in (3). In this particular case, it might be better in fact to encode this information using a feature rather than with types. But the idea of multiple inheritance will be crucial in the approach outlined in §4.

2.2 Lists of segments

In the physical realization of words and phrases, there is often no clear boundary between successive segments, and this overlapping articulation is responsible for many diachronic and synchronic phonological phenomena. But for the purposes of phonological analysis, most formal models assume that segments are realized one after the other. Previous proposals for HPSG phonology adopt this idealized representation, encoding the segmental content of words as a list of segments.

In fact, Bird and Klein (1994) propose a PHON value that includes three lists of segments, with the elements of the overall “skeletal” list split into a list of consonants and a list of vowels. Once again, this is a straightforward HPSG implementation of an existing phonological model, this time autosegmental phonology (Goldsmith, 1990). The following structure, for example, represents the word *ki-caaw* (Sierra Miwok):

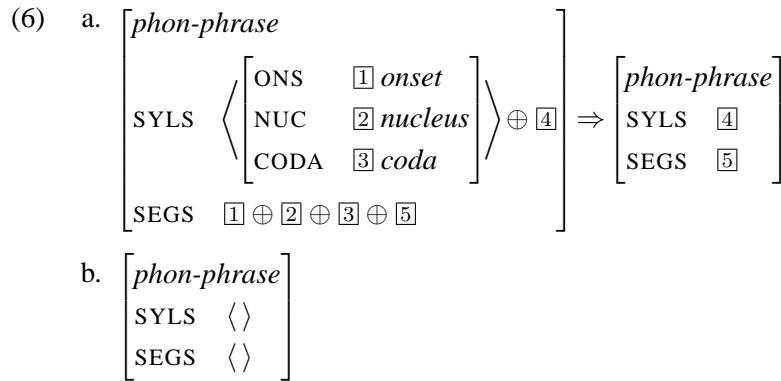

I will discuss Bird and Klein’s proposals more fully in the following sections.

While Höhle does not discuss syllable structure in any detail, the general model he sketches seems to follow an approach similar to that of Bird and Klein.

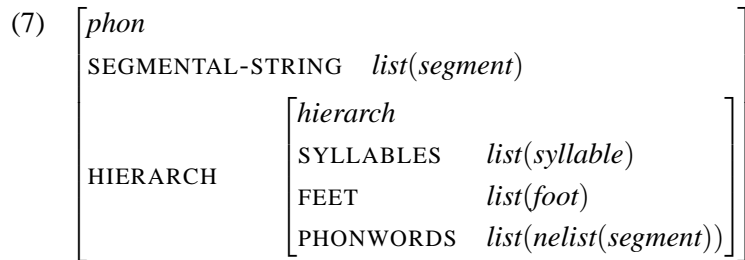

In other words, he assumes that the elements of the SEG-STRING list are organized into objects of type *syllable*, which appear in the SYLLABLES list. Syllables are in turn organized into feet. In most cases, the associations between levels of prosodic structure are rather straightforward and subject to strong well-formedness constraints (e.g. the Strict Layer Hypothesis, Selkirk, 1984). Höhle recognizes, however, that the relations between successive levels are not always so simple. According to some analyses, segments are not always exhaustively syllabified (e.g. extrasyllabicity), and some syllables are not fully integrated into feet (e.g. extrametricality/extraprosodicity). By the time he gets to the list of phonological words, Höhle gives up on the idea of making its value a list of *phonword* objects, a type which would presumably be defined in terms of *foot* objects, defined in turn in terms of *syllable* objects, defined in terms of *segments*. Instead, the value of PHONWORDS is declared to be less constrained, and to make direct reference to segments. No precise definitions are proposed for *syllable* and *feet*, either—i.e., it is left open whether they should be represented as lists or as more richly structured objects like Bird and Klein’s *syl*. Höhle’s comments seem to suggest that in the general case, it may turn out that the attributes SYLLABLES and FEET might also select values of the more flexible type *list(nelist(segment))*.

3.2 Problems with structural encoding

In this section I will point out some technical and conceptual difficulties with the kinds of approaches we have just seen, where hierarchical prosodic structure is encoded using hierarchically embedded representations. I will focus on the analysis of syllabification presented by Bird and Klein (1994).

Consider the English word *instrument*, for which we might assume the pronunciation [ʔin.stru.mənt]. This syllabic structure is shown in (8a) using tree notation and in (8b) as an AVM.

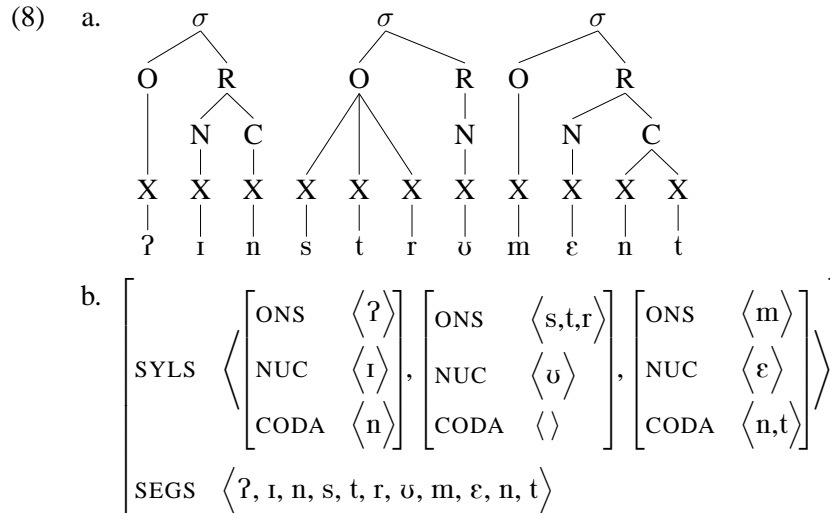

Apart from the absence of the rime subgrouping in (8b), which I assume is a simplification for expository purposes rather than a theoretical claim on the part of Bird and Klein, there are some important differences between these two structures. In the AVM, the segments are represented twice, or more precisely, each segment appears in two places by re-entrancy (not indicated in the figure above). Moreover, the attributes ONS, NUC, and CODA are unordered.

Thus a number of fundamental constraints on the well-formedness of syllables that hard-wired into the classic tree representation in (8a) have to be stated explicitly in the HPSG model. These include constraints against crossing branches and multiple association. Such illicit configurations can be represented just as easily as legitimate syllabifications in AVM form:

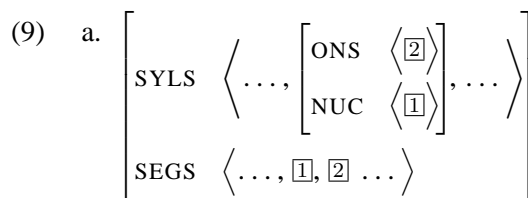

$$b. \left[\begin{array}{l} \text{SYLS} \langle \dots, [\text{CODA} \langle \underline{\text{I}} \rangle], \dots \rangle \\ \text{SEGS} \langle \dots, \underline{\text{I}}, \dots, \underline{\text{I}}, \dots \rangle \end{array} \right]$$

At the same time, some kinds of “interesting” configurations are possible in both representations. For example, ambisyllabicity could be represented as follows:⁴

$$(10) \quad a. \begin{array}{c} \sigma \qquad \sigma \\ \diagdown \quad \diagup \quad \diagdown \quad \diagup \\ \dots \quad C \quad O \quad \dots \\ \diagup \quad \diagdown \quad \diagup \\ X \quad X \quad X \end{array}$$

$$b. \left[\begin{array}{l} \text{SYLS} \langle \dots, [\text{CODA} \langle \underline{\text{I}} \rangle], [\text{ONS} \langle \underline{\text{I}} \rangle], \dots \rangle \\ \text{SEGS} \langle \dots, \underline{\text{I}}, \dots \rangle \end{array} \right]$$

It has always been recognized, of course, that the vast majority of structures in HPSG that are well-formed according to the signature have to be filtered out by grammatical constraints. In general, the expressive potential of the formalism is seen as an advantage by most practitioners of HPSG, as it enforces transparency and explicitness in analyses. It should always be kept in mind, however, that each time a new attribute is introduced, its value must be filled in somehow. Bird and Klein propose the syllabification constraint shown in (6) above, for example, to instantiate the value of SYLS. With the appropriate definitions for the types *onset*, *nucleus*, and *coda*, this constraint does allow canonical syllable structures as in (8b), and it could be modified if desired to allow structures like (10). But any variant of the constraint will have continue to enforce a measure of redundancy in the representation: the identity and order of the segments in the SEGS list must be preserved. In other words, in such an approach, information that is already present in one part of the sign must be systematically reproduced in another.

A more conceptual problem with the analysis of Bird and Klein is the assumption of exhaustive syllabification in (6). Phonological accounts of syllabification usually establish a set of rules and principles that allow every (grammatical) word or phrase to be completely parsed into syllables, and they typically strive to ensure that this syllabification is unique. This implies, among other things, that the boundaries between syllables are always well-defined. In reality, though, syllable boundaries can be difficult to identify (Angoujard, 1997).

Several kinds of evidence are available for determining syllabification in a given language: speaker’s intuitions (both introspective and semi-conscious, as in the case of secret languages and games), phonetic criteria, and phonological phenomena conditioned by syllable structure. For most languages, these criteria can be used reliably to identify syllable “peaks” and “troughs”, but they are not always

⁴Geminate consonants would receive a distinct representation, with the same segment appearing twice on the SEGS list; recall however fn. 2 on the use of the segments list as a timing tier.

sufficient for locating a precise syllable boundary in every trough. This is especially true of so-called “stress timing” languages like English. One manifestation of this difficulty is the phenomenon of ambisyllabicity, mentioned above in (10), in which it can be argued that a consonant occupies adjacent coda and onset positions at the same time. Another example of this indeterminacy is provided by the word *instrument* (8b), for which the alternative syllabification [ʔins.tru.mənt] can also be defended (Wells, 1990).

Bird and Klein’s model can be modified to allow two distinct, complete syllabifications of a word like *instrument*. This does not seem to be the right approach, however: the syllabification is not ambiguous, but indeterminate. It simply does not matter which syllable the [s] belongs to. A more radical reformulation of the constraint in (6) could relax the requirement of exhaustive syllabification and skip over some elements of SEGS in certain situations. But then these segments would appear nowhere in the SYLS value. There is no way to partially specify the role of a segment. We know, for instance, that the [s] in *instrument* is not a nucleus, but there is no way to express this in the SEGS and SYLS model (except again indirectly, using an explicit disjunction of incompatible feature structures).

4 Building on the segments list

The foregoing discussion leads us to the conclusion that constructing syllables in a separate part of the sign has undesirable consequences. In the remainder of this paper I will show that it is possible, and preferable, to encode information about syllabification (and higher levels of prosodic structure) directly in the list of segments by enriching segmental representations.

4.1 Type-based Prosodic Phonology

This idea has much in common with the Type-based Prosodic Phonology model presented by Crysmann (2002), extending proposals by Walther (1999). Crysmann assumes a simpler PHON structure than those discussed thus far, cf. (6) and (7). His PHON value is a list of *phon-obj* elements (segments with their articulatory features encoded in the SEGMENT value).

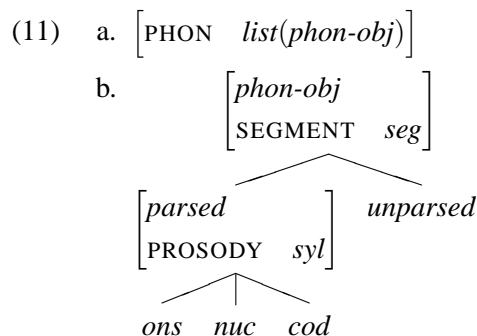

To represent syllabic structure in this approach, segments are not copied or mapped to another part of the sign, but their representations are enriched with prosodic information, directly in the segments list. The position of a segment within its syllable is encoded by means of subtypes of *phon-obj* (with the possibility that in some situations, a segment can remain unsyllabified, or *unparsed*).

Syllable grouping is encoded using the PROSODY value. Consecutive segments that occupy the onset, nucleus, and coda positions of the same syllable have token-identical PROS values. For example, the word [ʔin.stru.mɛnt] would be represented as follows:

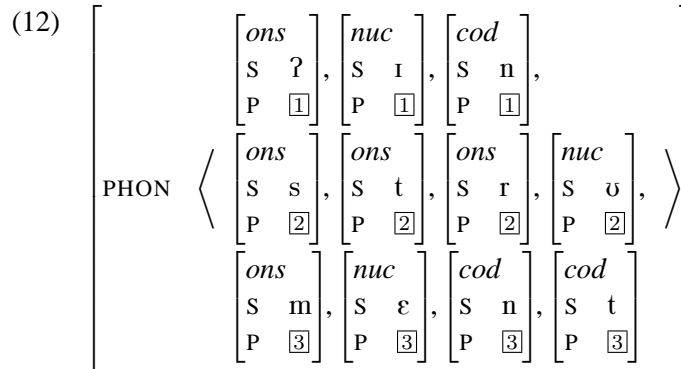

In addition, PROS values choose from a rich system of types, part of which is shown below:

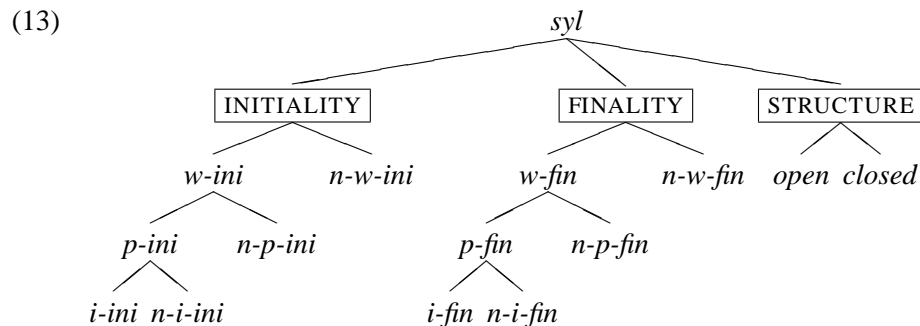

This multiple inheritance hierarchy allows the specification of the position and function of the syllable in question. In particular, the combinations of INITIALITY and FINALITY subtypes are used to indicate the composition of larger prosodic domains. If the syllable is at the left or right periphery of the prosodic word, it has the type *w-ini* or *w-fin*, respectively. Non-peripheral syllables bear the complementary types. In the example above, the syllable identified as 1 has the type *w-ini* & *n-w-fin*, syllable 2 is *n-w-ini* & *n-w-fin*, and syllable 3 is *n-w-ini* & *w-fin*. The other types are used analogously at the levels of phonological phrases and intonation phrases. This system of types can naturally be extended as needed. The relevant aspects of prosodic structure can thus be encoded directly in the segmental representation, without actually constructing a prosodic constituency tree using recursively embedded feature structures.

4.2 Questions and simplifications

Crysmann’s proposals are extensive and technically detailed (at times bewilderingly so), and his framework is applied to an impressive array of analyses. My purpose in this section is to bring up a number of questions about the general approach and to suggest some modifications.

First of all, using the segments list to represent the entire prosodic hierarchy (up to intonation phrases) raises concerns of locality. In this model, we could conceivably define a constraint requiring the first syllable of the second prosodic word of a phonological phrase to have a liquid coda, for example, or that the consonant [t] can only appear in the onset of the final syllable of an intonation phrase:

$$(14) \quad \text{a. } \left[\begin{array}{l} \text{dom-obj} \\ \text{PH } \text{list}([\text{P } \boxed{1} \text{ p-ini}]) \oplus \text{list}([\text{P } \text{ n-w-ini}]) \oplus \langle [\text{P } \boxed{2} \text{ w-ini}], \dots \rangle \end{array} \right]$$

$$\Rightarrow \left[\text{PH } \langle \dots, \left[\begin{array}{l} \text{cod} \\ \text{S } \text{liquid} \\ \text{P } \boxed{2} \end{array} \right], \dots \rangle \right]$$

$$\text{b. } \left[\begin{array}{l} \text{phon-obj} \\ \text{S } \text{t} \end{array} \right] \Rightarrow \left[\begin{array}{l} \text{ons} \\ \text{P } \text{i-fin} \end{array} \right]$$

These examples are obviously contrived, and there may in fact be phenomena where high level domains have to make reference to segmental content and the internal structure of syllables. Syllabification itself, after all, is best formulated as a constraint on phonological phrases, cf. (6). For most higher level phenomena, however, it would be preferable to enforce some notion of locality. This can be done by introducing an abstract list corresponding to the sequence of syllables. In contrast to the SYLS of Bird and Klein (1994), the members of this list do not provide a full phonological description of the syllables and their internal structure.

This proposal shares aspects of the analysis of phrasal prosody of Bonami and Delais-Roussarie (2006). They start from a flat list of segments (like the one assumed here), and they construct a more abstract structure—the metrical grid—containing one column for each syllable. At this level of analysis, only the succession of syllables is relevant, and information such as the identity of syllable nuclei or the nature of syllable boundaries is unnecessary and should be inaccessible (or only exceptionally accessible). I will develop this idea further at the end of this section.

Other questions are raised by Crysmann’s PROSODY feature. Recall that token identity of this value among consecutive segments indicates membership in the same syllable. This membership is determined by the syllabification principles of the language (that specify the possible nuclei, onsets, and codas, and how to determine syllable boundaries), subject to the following well-formedness conditions

(among others):⁵

- (15) a. $dom-obj \Rightarrow \neg \left[\text{PH} \quad list \oplus \langle \text{① } ons, \text{② } ons \vee nuc \rangle \oplus list \right]$
 $\wedge \neg (\text{① } [P \ 0] \wedge \text{② } [P \ 0])$
- b. $dom-obj \Rightarrow \neg \left[\text{PH} \quad list \oplus \langle \text{① } nuc \vee cod, \text{② } cod \rangle \oplus list \right]$
 $\wedge \neg (\text{① } [P \ 0] \wedge \text{② } [P \ 0])$
- c. $dom-obj \Rightarrow \neg \left[\text{PH} \quad list \oplus \left\langle \left[\begin{array}{c} nuc \\ P \ 0 \end{array} \right] \right\rangle \oplus list \oplus \left\langle \left[\begin{array}{c} nuc \\ P \ 0 \end{array} \right] \right\rangle \oplus list \right]$
- d. $dom-obj \Rightarrow \neg \left[\text{PH} \quad list \oplus \langle ons, cod \rangle \oplus list \right]$

The last constraint effectively requires every syllable to have a nucleus, and (15c) requires distinct nuclei to be associated with distinct syllables. (15a) and (15b) are implicational constraints that impose token-identity of PROS values for certain sequences of *phon-obj* elements. Together, the constraints interact to ensure that the PHON value of domain objects is parsed into syllables of the form onset-nucleus-coda (with possibly empty onset and/or coda), each with a unique PROS value.

We can ask at this point whether it is necessary to use token-identity of PROS values in this way. If the syllabification rules of the language identify an onset-nucleus-coda grouping, then the corresponding sublist of segments already constitutes a syllable. The PROS value, which encodes positional information, etc. in accordance with (13), does need to be linked to the syllable, for example in the representation of its nucleus. But what additional benefit is gained by copying this PROS value to all of the other segments of the syllable (onset and coda, if present)? And furthermore, is it crucial for syllables to be associated with unique PROS values, as required by the implicit inequality constraint in (15c)?

A significant simplification of the role of Crysmann's PROS feature can be achieved by introducing a SYLLABLES list of the kind discussed above, with abstract objects corresponding to syllables (but providing no direct access to their detailed internal content). This attribute is added to the PHON value, with the existing list of segments moved into SEGMENTS. First of all, we need to modify the part of the signature shown in (11b) to make PROSODY appropriate only for the subtype *nuc*. Then, we set up a one-to-one correspondence between the *nuc* elements of the SEGS list and the elements of the SYLLS list. This can be done with a recursively defined relational constraint⁶ or using the following pair of bidirectional implications:

⁵The formulation of (15b) corrects a minor mistake in Crysmann (2002), p. 281.

⁶Cf. the construction of the metrical grid in Bonami and Delais-Roussarie (2006).

$$\begin{array}{l}
(16) \text{ a. } \left[\begin{array}{l} \textit{dom-obj} \\ \text{PHON | SEGS } \textit{list} \oplus \left\langle \left[\begin{array}{l} \textit{nuc} \\ \text{PROS } \boxed{0} \end{array} \right] \right\rangle \oplus \textit{list} \end{array} \right] \\
\Leftrightarrow \left[\begin{array}{l} \textit{dom-obj} \\ \text{PHON | SYLLS } \textit{list} \oplus \langle \boxed{0} \rangle \oplus \textit{list} \end{array} \right] \\
\text{b. } \left[\begin{array}{l} \textit{dom-obj} \\ \text{PHON | SEGS } \textit{list} \oplus \left\langle \left[\begin{array}{l} \textit{nuc} \\ \text{PROS } \boxed{0} \end{array} \right] \right\rangle \oplus \textit{list} \oplus \left\langle \left[\begin{array}{l} \textit{nuc} \\ \text{PROS } \boxed{1} \end{array} \right] \right\rangle \oplus \textit{list} \end{array} \right] \\
\Leftrightarrow \left[\begin{array}{l} \textit{dom-obj} \\ \text{PHON | SYLLS } \textit{list} \oplus \langle \boxed{0} \rangle \oplus \textit{list} \oplus \langle \boxed{1} \rangle \oplus \textit{list} \end{array} \right]
\end{array}$$

Now that the uniqueness of each syllable is ensured by its position in the SYLLS list, there is no need to impose token non-identity of PROS values, as in (15c). Two nuclei could happen to have token identical values “by accident”; it is not clear what this would mean, but it seems unnecessary to block the possibility explicitly. They would still correspond to two elements in the SYLLS list. In practice, as the information encoded in the PROS value is enriched, type and feature incompatibilities will prevent such accidental structure sharing anyway.

In this modified approach, it is no longer possible to use the PROS feature directly to pick out all of the segments of a particular syllable. And because PROS values are not guaranteed to be unique, it is not even possible to choose an element from SYLLS and immediately identify the corresponding nucleus in SEGS. These operations can still be done, but in a more roundabout way: with information about the position of the element in the SYLLS list, the corresponding nucleus can be located, and any consecutive *onset* objects to the left and any consecutive *coda* objects to the right of this nucleus in the SEGS list are members of the same syllable.

Similarly, rules such as those invented in (14) to illustrate locality violations are not technically ruled out, but they become much harder to formulate. In other words, this modified model contains more or less the same information as that of Crysmann’s original proposal, but the re-structuring of the information makes predictions about the rarity or markedness of certain kinds of prosodic interaction.

5 Case study: French

In this final section I offer a more concrete illustration of the proposed framework by sketching the analyses of a number of phenomena from French. Bird and Klein (1994) also use French examples for their model of syllabification, so I will primarily concentrate on the same range of data.

5.1 Structurally-encoded syllables

Bird and Klein present a declarative analysis of the distribution of French schwa, an “unstable” vowel that can be left unrealized in certain lexical and syntactic environments, conditioned in large part by the syllabic structure of words in context.

- (17) debout [də.bu] vs il est debout [i.lɛ.də.bu] / [i.lɛd.bu]
 standing he is standing

The analysis is inspired by the autosegmental treatment of Tranel (1987a), in which schwa is underlyingly unlinked (to a V node) but must become linked and therefore realized phonologically if the surrounding consonantal configuration cannot otherwise be syllabified.

To implement the insights of this analysis in their HPSG model, Bird and Klein provide a provisional statement of the phonotactics of French, based on Tranel (1987b). Syllable nuclei are always single vowels; in other words, the type *nucleus* is defined as $\langle vowel \rangle$. Permissible onsets and codas are enumerated in the following type hierarchies:

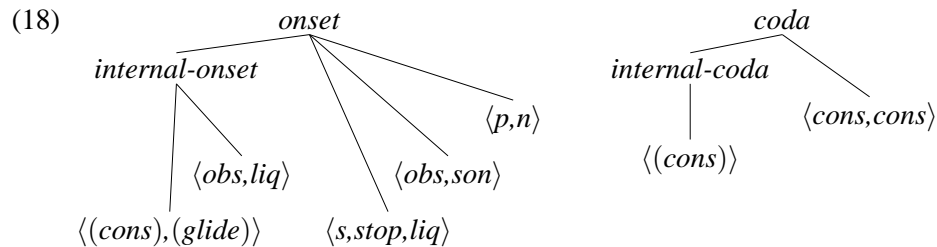

The *internal* subtypes are meant to capture the generalization that word-internal onsets and codas are more restricted than word-initial onsets and word-final codas. These definitions, in combination with the syllabification constraint formulated in (6), produce possible syllable structures for phonological phrases.

Some empirical and technical problems should be mentioned at this point. The precise inventory of possible onsets and codas is incomplete (for example, *exploit* [ɛksplwa] ‘feat’ contains a sequence of consonants at the syllable boundary that cannot be accommodated), and Bird and Klein acknowledge this. I will not pursue the issue further.

Bird and Klein do not explain how the type distinctions between word-internal and word-peripheral onsets and codas can be put to use as constraints on syllabification. A crucial assumption of the analysis is that words are not fully syllabified at the lexical level, since the syllabic structure at word boundaries cannot yet be determined. But at the phonological phrase level, where full syllabification takes place, the SEGS value is a long list of segments with no indication of word boundaries. One could argue that this information in fact needs to be propagated so that it remains visible at the phrasal level. The formulation of the constraint in (6) would have to be modified in order to apply different restrictions depending on the context within the phrase.

The fact that both onsets and codas can be empty, and that some sequences of segments can appear in both positions, leads to many cases of indeterminacy. Bird and Klein, however, assume full and unique syllabification, and they achieve this by formulating additional constraints that echo the familiar principle of onset maximization. In the simplest case, if only one consonant appears at a syllable boundary, it must be syllabified as the onset, leaving the preceding coda empty, rather than vice versa. So for instance *euro* should be analyzed as [ø.ʁo], not as [øʁ.o]. Another onset maximization constraint involves obstruent-liquid sequences, which always syllabify together in French, as in [a.bʁi] ‘shelter’ (where the consonant sequence could otherwise be split across two syllables: [ab.ʁi]). Obstruent-liquid sequences are notorious for their unusual behavior. Historically, for example, in the transition from Latin to French, the syllable boundary shifted at least twice.

As discussed in §3.2, indeterminacy is sometimes an inherent characteristic of syllable boundaries, and an adequate analysis should be able to accommodate it, and not strive to eliminate it artificially. It should be said that French is relatively unproblematic in this regard, and Bird and Klein’s onset maximization constraints are not unreasonable. It has already been pointed out, however, that as a general model, their SYLS structures are ill-equipped to deal with cases where the appropriate representation would be a genuinely underspecified syllable boundary.

5.2 Type-encoded syllables

Recall that in my approach, information about syllable structure is added directly to the list of segments, and no separate syllabic “constituent structure” is built. First of all, I redefine Bird and Klein’s types *onset* and *coda* as description-language abbreviations for disjunctions of lists (since the interpretation of the onset and coda inventories in (18) as type hierarchies leads to some technical difficulties):

- (19) onsets
- a. internal-onset $\equiv \langle (cons), (glide) \rangle \vee \langle obs, liq \rangle$
 - b. onset $\equiv \text{internal-onset} \vee \langle s, stop, liq \rangle \vee \langle obs, son \rangle \vee \langle p, n \rangle$
- (20) codas
- a. internal-coda $\equiv \langle (cons) \rangle$
 - b. coda $\equiv \text{internal-coda} \vee \langle cons, cons \rangle$

We can now use these abbreviations—along with the fact that syllable nuclei in French consist of single vowels—to define syllable patterns.

- (21)
- a. initial-syllable $\equiv \text{onset} \oplus \langle (vowel) \rangle \oplus \text{internal-coda}$
 - b. medial-syllable $\equiv \text{internal-onset} \oplus \langle (vowel) \rangle \oplus \text{internal-coda}$
 - c. final-syllable $\equiv \text{internal-onset} \oplus \langle (vowel) \rangle \oplus \text{coda}$
 - d. monosyllable $\equiv \text{onset} \oplus \langle (vowel) \rangle \oplus \text{coda}$

Distinct definitions are provided for word-initial, word-medial, and word-final syllables for two reasons. First, this is necessary in order to enforce the distinction

between word-internal and word-peripheral onsets and codas. Word-medial syllables are the most restricted: they must contain a vowel and their onsets and codas are taken from the reduced word-internal inventories. Initial and final syllables are less constrained on their word-peripheral side. Second, and more crucially for the analysis of schwa and other word-boundary “readjustment” phenomena, peripheral syllables are allowed not to contain a vowel (or more precisely, to contain an optional vowel).

Using these definitions we can formulate the following constraint on words:

$$(22) \text{ word} \Rightarrow \left[\text{SEGS } (\textit{init-syll} \oplus \textit{med-syll}^* \oplus \textit{fin-syll}) \vee \textit{monosyll} \right]$$

The first clause of the disjunction is for words of two or more syllables (the Kleene star notation indicates the occurrence of zero or more medial syllables), the second for monosyllables.

Following Bird and Klein, I assume that words like *debout* (17) or *fenêtre* ‘window’ have a lexically underspecified SEGMENTS list containing an optional schwa in their initial syllable:

$$(23) \quad \begin{array}{ll} \text{a. } \textit{debout}: & \text{b. } \textit{fen\^e}tre: \\ \left[\text{SEGS } \langle \text{d}, (\text{\textcircled{a}}), \text{b}, \text{u} \rangle \right] & \left[\text{SEGS } \langle \text{f}, (\text{\textcircled{a}}), \text{n}, \text{\textepsilon}, \text{t}, \text{\textbeta} \rangle \right] \end{array}$$

The constraint in (22) verifies the phonotactic well-formedness of the medial onsets and codas. The special treatment of the initial syllable allows the optional schwa to remain optional. If full syllabification were applied already, the schwa would be forced to appear (since ⟨d, b⟩ and ⟨f, n⟩ are not possible onsets according to (19)). On the other hand, a form like **d(e)b.pnout* would be rejected for containing an unsyllabifiable medial onset, and **ft(e).n\^e.tre* would be rejected for having an impossible word-initial onset.

Final syllables also require this special treatment, because they are the locus of vowel elision (24) and *encha\^n*ement of final consonants (25):

$$(24) \quad \begin{array}{ll} \textit{quoique} [\text{kwa.k}\text{\textcircled{a}}] \text{ vs } \textit{quoiqu}' \textit{int}\text{\textcircled{e}}ressant [\text{kwa.k}\text{\textcircled{e}}.te.\text{\textbeta}e.s\text{\textcircled{a}}] \\ \text{albeit} & \text{albeit} \quad \text{interesting} \end{array}$$

$$(25) \quad \begin{array}{ll} \textit{avec} [\text{a.v}\text{\textepsilon}\text{k}] \text{ vs } \textit{avec un ami} [\text{a.v}\text{\textepsilon}.k\text{\textcircled{e}}.na.mi] \\ \text{with} & \text{with a} \quad \text{friend} \end{array}$$

The final schwa of *quoique* is also represented as an optional segment in its lexical SEGMENTS list: ⟨k, w, a, k, (ə)⟩. The final consonant of *avec* is of course not optional, since it is realized in all contexts. The constraint in (22) checks that ⟨k⟩ is a possible coda, but it does not actually declare it to be a coda (since it can turn out to be an onset in phrasal combinations). In fact, no subsyllabic roles are instantiated by this constraint.

At this point, moreover, no attempt is made to reduce ambiguity in syllabification at the word level. Words like *euro* and *abri*, discussed above, will simply satisfy the constraint in (22) in more than one way. This does not result in multiple analyses, however, because so far we are only doing pattern matching, without

adding any information when a pattern is found. Bird and Klein discuss the case of *demandērions* ‘we would ask’, in which the choice between a syllabification with and without the second (underlined> schwa can in principle be made at the word level:

- (26) a. $\left[\text{SEGS} \left\langle \text{d}, (\text{ə}) \mid \text{m}, \tilde{\text{a}} \mid \text{d}, \text{ə} \mid \text{ʁ}, \text{j}, \tilde{\text{ɔ}} \right\rangle \right]$
 b. $* \left[\text{SEGS} \left\langle \text{d}, (\text{ə}) \mid \text{m}, \tilde{\text{a}}, \text{d} \mid \text{ʁ}, \text{j}, \tilde{\text{ɔ}} \right\rangle \right]$
 c. $\left[\text{SEGS} \left\langle \text{d}, (\text{ə}), \text{m}, \tilde{\text{a}}, \text{d}, (\text{ə}), \text{ʁ}, \text{j}, \tilde{\text{ɔ}} \right\rangle \right]$

For Bird and Klein, the pronunciation without schwa in (26b) is excluded by the onset maximization constraint requiring obstruent-liquid clusters to syllabify together: so $\langle \text{d}, \text{ʁ} \rangle$ must be in the onset, but $\langle \text{d}, \text{ʁ}, \text{j} \rangle$ is not an allowable onset, according to (19). In my analysis, at the word level, there is no way to enforce onset maximization, since the constraint in (22) only checks potential syllable structures and does not actually instantiate them. So both SEGS lists in (26) are maintained: in other words, both of the schwas in *demandērions* remain optional (26c).

In ordinary phrasal combinations, the SEGS lists of the daughters are concatenated to yield the SEGS list of the mother.⁷ The following constraint is the counterpart to Bird and Klein’s syllabification constraint (6):

$$(27) \textit{phrase} \Rightarrow \left[\text{SEGS} \textit{syllable}^+ \right]$$

In other words, a phonological phrase has to look like the concatenation of one or more syllables. There is no need to define a recursive relation as in (6) to be sure that all of the elements of SEGS are parsed. Just as in the word-level constraint in (22) above, the sequence of syllables identified automatically partitions the entire SEGS list. But in this case, the definition of *syllable* does not just specify a pattern to match: it also enriches the representation by instantiating the type each segment as *onset*, *nucleus*, or *coda*, cf. the hierarchy in (11b).

$$(28) \textit{syllable} \equiv \textit{onset} \ \& \ \textit{list}(\textit{onset}) \oplus \langle \textit{vowel} \ \& \ \textit{nucl} \rangle \oplus \textit{coda} \ \& \ \textit{list}(\textit{coda})$$

As discussed in §4, the linear ordering already inherent in the SEGS list is now enriched with information about syllabification. Most of the structure encoded in Bird and Klein’s SYLS list is represented directly in the SEGS list. At this point, if desired, we can express onset maximization principles as constraints on SEGS. For example, $[\emptyset.\text{ʁ}\text{ɔ}]$ (*euro*) and $[\text{a}.\text{b}\text{ʁ}\text{i}]$ (*abri*) can be preferred to $[\emptyset\text{ʁ}.\text{ɔ}]$ and $[\text{a}\text{b}.\text{ʁ}\text{i}]$. And the schwa-less pronunciation of *demandērions* in (26b) can be excluded by

⁷I leave aside cases of consonant liaison, where a “latent consonant” appears at the boundary between two words. The proposals in this paper are compatible with the analysis of liaison developed in Bonami et al. (2004, 2005). Unlike schwa in the present analysis, the liaison consonant must not be treated as an optional segment.

prohibiting sequences of an obstruent segment of type *coda* followed by a liquid segment of type *onset*.⁸

Note also that according to (28), every **syllable** must contain a vowel. If a word like *debout*, with an optional schwa thanks to the definition of **initial-syllable** (21a), appears at the beginning of the phonological phrase, the schwa will have to be realized. Within the phrase, the realization of schwa in word-initial syllables will be conditioned by the preceding context. Words like *avec* will either have their final consonant syllabified as a coda, or in the onset of the following syllable, again depending on the phrasal context.

5.3 Discussion

The analysis presented here has more or less the same empirical coverage as the original account of Bird and Klein (1994). I have extended the implementation of some word-level phonotactic conditions that were left out of their account, and suggested how the approach can be applied to some other word boundary phenomena (elision, *enchaînement*). But the main purpose of this presentation is to demonstrate that the insights and the results of the original analysis can be preserved while dispensing with the hierarchical encoding of syllable structure.

As discussed already, however, there are technical and conceptual advantages to the type-based encoding of syllable structure in the segments list, in particular with regard to underspecification. With a structural encoding of syllables, there is no easy way to capture the sometimes unstable and fuzzy interactions at syllable boundaries. In the type-based approach, underspecification is a simple matter of enriching the type hierarchy with intermediate types such as *non-nucl*. Even a disjunctive type specification like *ons* \vee *cod* would be much simpler than the disjunction of complex feature structures that is required to express the same idea in the structural approach.

The segments list approach also allows segments to be associated with particular syllabic positions, either in specific lexical items or as a general property of the language, thus constraining the application of phrasal syllabification (28). This is not specifically relevant to the analyses discussed here, but it provides a natural way to express, for instance, the fact that [ŋ] is restricted to coda position, or that there are no syllabic consonants in French. Such generalizations cannot be elegantly expressed in the structural approach.

References

Angoujard, Jean-Pierre. 1997. *Théorie de la syllabe*. Paris: CNRS Editions.

Bird, Steven and Klein, Ewan E. 1994. Phonological analysis in typed feature systems. *Computational Linguistics* 20, 455–491.

⁸Other analyses should also be considered; the point here is that Bird and Klein's account can be reproduced with the current proposal.

- Bonami, Olivier, Boyé, Gilles and Tseng, Jesse. 2004. An integrated approach to French liaison. In Gerhard Jäger, Paola Monachesi, Gerald Penn and Shuly Wintner (eds.), *Proceedings of Formal Grammar 2004*, pages 29–45, Nancy: Loria.
- Bonami, Olivier, Boyé, Gilles and Tseng, Jesse. 2005. Sur la grammaire des consonnes latentes. *Langages* 158, 89–100.
- Bonami, Olivier and Delais-Roussarie, Elisabeth. 2006. Metrical phonology in HPSG. In Stefan Müller (ed.), *Proceedings of the 13th International Conference on HPSG*, pages 39–59, Stanford, CA: CSLI Publications.
- Clements, Nick G. 1985. The geometry of phonological features. *Phonology* 2, 223–250.
- Crysmann, Berthold. 2002. *Constraint-based Coanalysis: Portuguese cliticisation and morphology-syntax interaction in HPSG*. Ph. D.thesis, Universität des Saarlandes.
- Goldsmith, John A. 1990. *Autosegmental and metrical phonology*. Oxford: Blackwell.
- Höhle, Tilman N. 1999. An Architecture for Phonology. In Robert D. Borsley and Adam Przepiórkowski (eds.), *Slavic in Head-Driven Phrase Structure Grammar*, pages 61–90, Stanford, CA: CSLI Publications.
- Klein, Ewan. 2001. Prosodic constituency in HPSG. In Ronnie Cann, Claire Grover and Philip Miller (eds.), *Grammatical Interfaces in HPSG*, pages 169–200, Stanford, CA: CSLI Publications.
- Pollard, Carl and Sag, Ivan A. 1994. *Head-Driven Phrase Structure Grammar*. Stanford, CA: CSLI Publications, distributed by University of Chicago Press.
- Selkirk, Elisabeth O. 1984. *Phonology and Syntax*. Cambridge, MA: MIT Press.
- Tranel, Bernard. 1987a. French schwa and nonlinear phonology. *Linguistics* 25(5), 845–866.
- Tranel, Bernard. 1987b. *The Sounds of French. An Introduction*. Cambridge: Cambridge University Press.
- Walther, M. 1999. *Deklarative Prosodische Morphologie*, volume 399 of *Linguistische Arbeiten*. Tübingen: Niemeyer.
- Wells, John C. 1990. Syllabification and allophony. In Susan Ramsaran (ed.), *Studies in the pronunciation of English: A commemorative volume in honour of A. C. Gimson*, pages 76–86, London: Routledge.