

Transparent Free Relatives in English

Eun-Jung Yoo

Seoul National University

Proceedings of the HPSG08 Conference

NICT, Keihanna, Japan

Stefan Müller (Editor)

2008

CSLI Publications

<http://csli-publications.stanford.edu/>

Abstract

Transparent free relatives (TFRs) are constituents involving a WH-gap dependency in which the phrase that is predicated of the gap associated with *what*, not the *wh*-phrase itself, functions as the syntactic and semantic ‘nucleus.’ Previous analyses have either treated TFRs as a construction radically different from ordinary FRs, utilizing such mechanisms as parenthetical placement or grafts, or assimilated them to ordinary FRs, relying on abstract/empty head elements and a vague semantic relation holding between the gap and the predicate phrase. In this paper, we investigate how the puzzling properties of English TFRs can be accounted for in HPSG. The paper shows that the ‘transparency’ effect of TFRs can be handled by feature inheritance from the ‘nucleus’ predicate phrase, together with a constructional constraint that deals with the exocentric property of TFRs.

1 Introduction

Transparent free relatives (TFRs) are bracketed phrases in examples like (1), which, despite their formal resemblance to standard free relatives (SFRs) involving filler-gap relations, demonstrate some significant differences.

- (1) a. He made [what appears to be **a radically new proposal**].
- b. He made an uninspired and [what I’d describe as **catastrophic**] decision.
- c. I didn’t get a chance to talk to him [what you might call **privately**].
- d. He felt my mother was [what he called **poisoning my mind**]. (Grosu 2003:248)

Most notably, TFRs are different from SFRs in that as in (1), the (bold-faced) predicate parts, not the *wh*-phrases, function as the syntactic and semantic ‘nucleus’. Within the TFRs in (1), each bold-faced phrase, which is dubbed as ‘transparent nucleus (TN)’ by Grosu (2003), is predicated of what corresponds to the trace of *what*. Thus, TFRs are often described as involving a small clause consisting of the trace of *what* and a predicate XP, as in (2).

- (2) He made [what appears to be [_{SC} t **a radically new proposal**]]. (Grosu 2003:278)

Syntactic headhood of a TN is exhibited through category matching. As shown in each example in (1), the syntactic category of the TN (i.e., the bold-faced part) matches to that of the TFR (i.e., the bracketed part). This is most clearly demonstrated in examples like (1b), in which the TFR must be an ADJP as an NP modifier, not being an NP inheriting the category of *what*.

Semantically, given a TN, the rest of the TFR is felt to be a parenthetical modifier of the TN, involving a ‘hedging’ effect. However, it is different from a normal parenthetical or a simple modifier that does not affect the core content. As shown in

(3), it is possible that even the speaker does not assume the proposition expressed by the TN (or the ‘small clause’) to be true.

- (3) a. There is now on your plate [what no one in his right mind would call **a steak**] (e.g., because it is in fact a dead rat).
- b. Bill is [what nobody would call **an optimist**]. (He thinks the world will end soon.)

In this respect, we assume a more formal characterization suggested in Grosu (2003:279), which states that a TN needs to be “in the scope of a TFR-internal intensional operator”.

Furthermore, in contrast to ordinary FRs in examples like *John ate what she cooked*, which have a definite or a (free choice) universal interpretation, a TFR may have an indefinite reading as evidenced by its occurrence in an existential *there* sentence in (4).

- (4) There is [what appears to be **an error**] in this program. (Wilder 1999:688)

In addition, while SFRs involve a set of *wh*-words such as *what*, *who*, *how*, *when*, and *where*, with their corresponding *-ever* forms, TFRs employ only *what*.

- (5) a. Bob is a boring and [what/*who/*where I would describe as highly irritating] person.
- b. Bob can be a boring and [what(*ever) I would describe as highly irritating] person. (Grosu 2003:307)

On the other hand, since both TFRs and SFRs have a basic internal structure involving a filler-gap dependency, the same string of a clause may be ambiguous between an SFR and TFR (Wilder 1999:694).

- (6) This was [what I described as sophisticated]. (ambiguous)

In (6), the bracketed clause can be either interpreted as a definite NP as an SFR or as an AP as a TFR.

In this paper, we investigate how the puzzling properties of English TFRs can be accounted for in HPSG. This paper shows that the ‘transparency’ effect of TRFs can be handled by feature inheritance from the TN, together with a constructional constraint that deals with the exocentric property of TFRs.

2 Previous Analyses of TFRs

Since the phenomenon was first introduced under the term *pseudo-free relatives* by Nakau (1971), and elaborated by Kajita (1977), TFRs had been largely unattended to in syntactic literature, until Wilder (1999), Grosu (2002, 2003), and Riemsdijk (2000, 2001, 2006a,b) carried out a more systematic investigation on the properties and grammatical analyses of the construction.

Except for Grosu (2002, 2003), other works treat TFRs as a construction radically different from ordinary relatives. In Wilder (1999), a TFR, which exists as a phrase marker independent of the matrix clause in syntax, is parenthetically placed to be left-adjacent to the nucleus XP, and then the overlapping underlined part undergoes backward deletion, as shown in (7).

- (7) John bought < what he took to be a guitar > a guitar (PF representation, Wilder:693)

However, as Riemsdijk (2000, 2001) points out, such an analysis has a critical problem that it cannot account for TFRs that have ‘string-medial’ TNs as in (8).

- (8) I just saw [what might well be taken for **a meteor** by naive observers when visibility is rather poor]. (Grosu 2003:288)

Riemsdijk (2006b) takes a further move and proposes that sentences with TFRs be derived by ‘grafts’ by which two independent input trees are connected via external remergers of internal elements, thus sharing a constituent (i.e., the TN of a TFR). According to Riemsdijk, the derivation of (9) consists of three steps in (10).

- (9) I ate what they called a steak.

- (10) a. Step 1 (internal merge of the subject of the TFR)

input tree B (TFR):

[*IP* they [*vP* (they) [*VP* call [*SC* what [*DP* a steak]]]]]

- b. Step 2 (internal (re-)merger (*wh*-movement) of *what*)

input tree B (TFR):

[*CP* what [*IP* they [*vP* (they) [*VP* call [*SC* (what) [*DP* a steak]]]]]]]

- c. Step 3 (**external merge of an internal element** in the TFR to the partial matrix tree)

input tree A (matrix):

.. [*V'* eat [*DP* a steak]]

input tree B (TFR):

[*CP* what [*IP* they [*vP* (they) [*VP* call [*SC* (what) [*DP* a steak]]]]]]]

⇒ *input tree A with a graft* (matrix):

.. [*V'* eat [*DP* **a steak**]] (The DP node is shared with that of the input tree B.)

As Riemsdijk (2006:27) himself discusses, such a derivation violates Phase Theory under the (standard) assumption that the building of tree B is completed before the graft in Step 3 is applied. In order to avoid this problem, Riemsdijk (2006:28) claims that “graft may apply at any state (DP, SC, VP, vP) until the vP is sent off to spell-out (PF).”

However, without an explicit account of the mechanism by which Phase Theory, graft, and spell-out interact with one another, it is largely left unclear how such process works. Furthermore, although Riemsdijk argues that grafts are natural phenomena that arise from merge, he does not provide any specific constraint that is necessary to restrict the huge amount of overgenerated TFR or other structures that may result from various external-internal merge possibilities.

By contrast, in Grosu (2003), TFRs are analyzed as basically the same kind of construction as ordinary FRs, which consist of a null head and a CP with an initial *wh*-phrase.

- (11) a. SFR
 $[XP [X(P) e] [CP wh-XP_i [C' [C [Def]] [IP \dots t_i \dots]]]]$
 b. TFR
 $[XP [X(P) e] [CP what_i [C' [C [Def]] [IP \dots [SC t_i TN] \dots]]]]$
 (Equative relation: $[SC t_i \Leftrightarrow TN]$)

According to Grosu, the transparency effect is induced from the ‘equative’ relation holding between the small clause subject, i.e., the trace of *what*, and the TN within a TFR.

However, Grosu’s analysis of TFRs has some drawbacks. First, in both (11a) and (11b), it is not clear and how the syntactic category of the *wh*-phrase is identified with that of the empty head. Second, Grosu fails to provide a precise syntactic mechanism by which the syntactic (and semantic) features of a TN are passed into the trace of *what* in (11b). Although Grosu claims that this is made possible through the equative relation between the trace of *what* and the TN, it is not clear at all how the equation of semantic objects (i.e., properties) in TFRs guarantees syntactic matching between the trace of *what* and the TN. Therefore, in this ‘unified’ analysis, the syntactic (and semantic) parallelism between TFRs and ordinary FRs remains only schematic, without theoretical details provided.

3 An HPSG Analysis

Our analysis focuses on explaining two major properties of TFRs, that is, i) the predicate phrase is the syntactic nucleus of TFRs, and ii) TFRs are far more restricted than the other kinds of *wh*-clauses such as relative clauses and SFRs.

First of all, in order to distinguish the *wh*-phrase occurring in TFRs, a new feature TFR(EL) is introduced with its value a set of indices. Accordingly, *what*, the only *wh*-phrase used in TFRs, is assumed to have the following specification:

- (12) *what*: $\left[\begin{array}{l} \text{CONT|IND } \boxed{1} \\ \text{TFR } \{ \boxed{1} \} \end{array} \right]$

Although the *wh*-phrase is a filler as in other types of *wh*-clauses, the following clause with a gap does not constitute the head in TFRs. In this respect, we analyze

TFRs as a kind of exocentric filler-base construction in (13) proposed by Wright and Kathol (2003).

- (13) Filler-nonhead construction (for free relatives, Wright and Kathol:383)

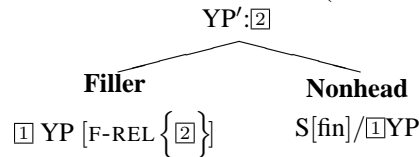

However, in contrast to the FR construction in Wright and Kathol, in which major HEAD information comes from the filler daughter, in our analysis of TFRs, the HEAD information indirectly comes from that of the TN embedded in the nonhead daughter S, as will be shown shortly.

Next, in order to capture the generalization that the TN is predicated of (the trace of) *what* (Wilder 1999, Grosu 2003) in examples like (14), the constraint in (15) is posited.

- (14) John invited [what she took to be _ a policeman].

- (15) EXT-HEAD-Licensing Constraint (preliminary)

$$\left[\begin{array}{l} \text{word} \\ \text{HEAD } \boxed{2} \\ \text{SUBJ } \langle \text{[TFR } \{ \boxed{1} \}] \rangle \end{array} \right] \Rightarrow \left[\text{EXT-HEAD } \boxed{2} \right]$$

The constraint (15) is imposed on any word that may appear as the lexical head of a TN phrase. Accordingly, it has an effect of restricting TNs to the phrases that take the TFR *wh*-phrase, *what*, as its (expressed or unexpressed) subject. In (15), the feature EXT-HEAD is introduced so that the HEAD information of the TN may be inherited into other phrases. We assume that basically, the EXT-HEAD is subject to Ginzburg and Sag's (2000) Generalized Head Feature Principle (GHFP). Additionally, at a lexical level, we need a restricted version of "Amalgamation Constraint" (cf. Ginzburg and Sag, for WH and STORE features) for the EXT-HEAD, as in (16).

- (16) EXT-HEAD-Amalgamation Constraint

$$\left[\begin{array}{l} \text{word} \\ \text{VAL|COMPS } \left\langle \left[\begin{array}{l} \text{SUBJ } \langle \text{[TFR } \{ \boxed{1} \}] \rangle \\ \text{EXT-HEAD } \boxed{2} \end{array} \right] \right\rangle \end{array} \right] \Rightarrow \left[\text{EXT-HEAD } \boxed{2} \right]$$

The constraint (16) states that the lexical amalgamation of the EXT-HEAD value occurs when a word have a TFR *wh*-phrase as its subject. Accordingly, the inheritance of the EXT-HEAD value of the TN in (14) can be illustrated as in (17).

(17)

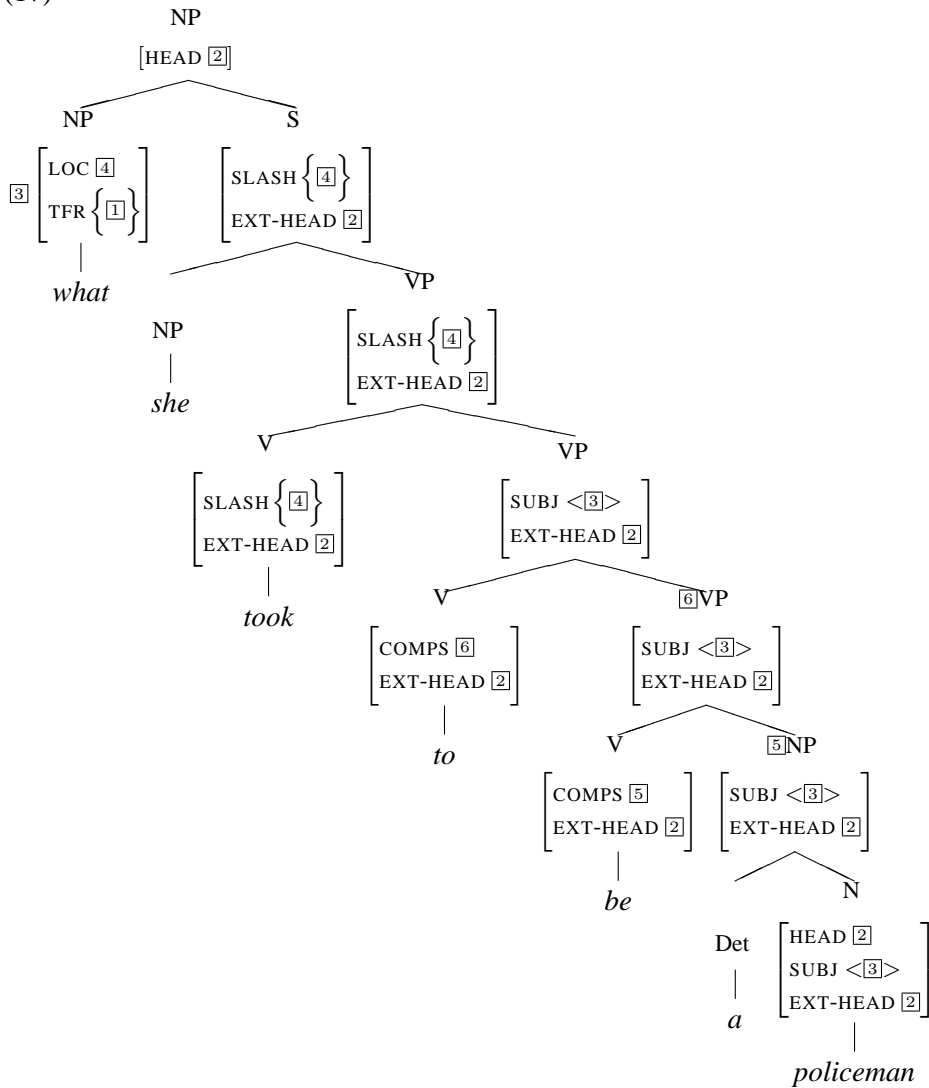

In (17), the filler-gap dependency is constrained by the Argument Realization Principle and SLASH-Amalgamation Constraint (cf. Ginzburg and Sag 2000, and Bouma et al. 2001), and the verb *took* has the following information:

(18) *took*

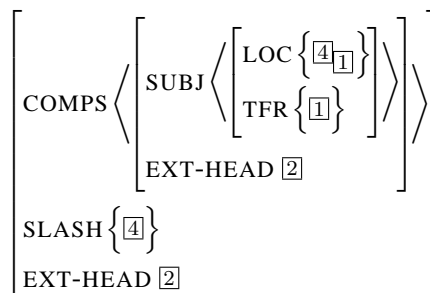

Moreover, in (17), the EXT-HEAD values of the lexical heads *to* and *be* are also governed by (16).

At this point, there is one important addition to be made on the constraint (15), because the constraint (15) as it is will cause an undesirable consequence for subject raising predicates with respect to their EXT-HEAD values. For example, predicates *be* and *to* in (14) as well as *appears* in (1a) would project their own HEAD values into EXT-HEAD values by (15), and this will make a conflict with the EXT-HEAD values that they inherit from the TNs by the constraint (16). In order to prevent the constraint (15) from applying to subject raising predicates, we revise the constraint as in (19):

$$(19) \text{ EXT-HEAD-Licensing Constraint (revised)}$$

$$\left[\begin{array}{l} \textit{word} \\ \text{HEAD } [2] \\ \text{SUBJ } \langle [\text{TFR } \{1\}] \rangle \\ \text{COMPS } \neg \langle [\text{SUBJ } \langle [\text{TFR } \{1\}] \rangle] \rangle \end{array} \right] \Rightarrow [\text{EXT-HEAD } [2]]$$

Therefore, the constraint in (16) and (19), together with the GHFP, can account for how the HEAD information of the bold-faced TN parts is inherited into the given TFR in more complex sentences as in (20).

- (20) a. There is now in that corner [what might conceivably be assumed [to look like **a dragon** to me] by anyone unfamiliar with my perceptions].
 b. I just noticed [what may well seem [to be construable as **an NP** by proponents of LFG] to people unfamiliar with that theory].¹ (Grosu 2003:288)

Now, another important question is how the top portion of a TFR clause is licensed. As mentioned earlier, we propose that TFRs constitute a kind of exocentric filler-base construction in the sense of Wright and Kathol. As a subtype of *filler-nonhead-construction*, we propose the *tr(ansparent)-fr(ee)-rel(ative)-cx*, with its constructional constraint in (21).

$$(21) \text{ tr-fr-rel-cx} \Rightarrow$$

$$\begin{array}{c} \text{YP } [\text{HEAD } [2]] \\ \swarrow \quad \searrow \\ \text{Filler} \quad \text{Nonhead} \\ \text{NP } \left[\begin{array}{l} \text{LOC } [4] \\ \text{TFR } \{1\} \end{array} \right] \quad \text{S } \left[\begin{array}{l} \text{SLASH } \{4\} \\ \text{EXT-HEAD } \{2\} \end{array} \right] \end{array}$$

¹In examples like (20b), the element *as* can probably be treated as a kind of marker, rather than a preposition, as in small clause constructions such as *We regard Kim as quite acceptable* and *We regard Kim as among the most acceptable candidates*. (Cf. Pollard and Sag 1994:108-110)

Accordingly, the top NP in (17) has the HEAD value that is structure-shared with the EXT-HEAD value of the nonhead daughter, which is inherited all the way from the TN, *a policeman*.

While the HEAD value of a TFR is treated as being identical with that of the TN, the semantics of the TFR should be different from that of the TN, because the interpretation of the other parts of the TFR, including an intensional operator, must be included as well. For TFRs with a non-nominal interpretation as in (22), we can derive the CONTENT value as in (23).

(22) The decision was [what Jane described as stupid].

(23) Example of *tr-fr-rel-cx* (a non-nominal case)

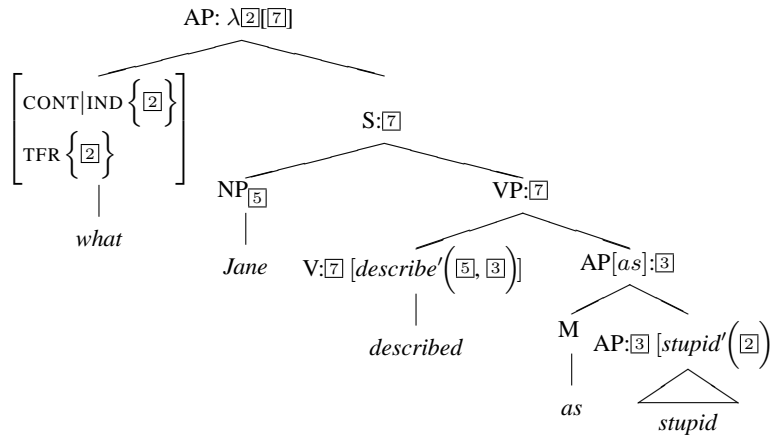

In (23), the CONTENT|NUCLEUS value of a non-nominal TFR is assumed to be structure-shared with that of the nonhead daughter S. (See the second constructional constraint for non-nominal TFRs in (24).)

On the other hand, for TFRs with a nominal interpretation, we assume that an existential quantifier is introduced to the constructional content of the *tr-fr-rel-cx*, because examples like (14) are interpreted as ‘John invited someone that she took to be a policeman.’ In TFRs with a nominal interpretation, the meaning of the nonhead daughter S contributes to the restriction of the quantifier, which is guaranteed by the additional constraints of the construction *tr-fr-rel-cx*.

(24) *tr-fr-rel-cx* ⇒

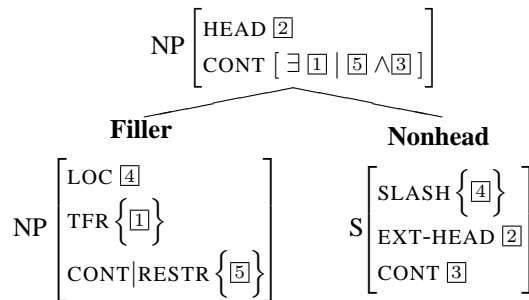

or

- Relatives. *Natural Language and Linguistic Theory* 21: 247-331.
- Kajita, Masaru. 1977. Towards a dynamic Model of Syntax. *Studies in English Linguistics* 5, 44-66.
- Nakau, Minoru. 1971. The Grammar of the Pseudo-Free Relative Pronoun *what*. *English Linguistics* 6, 2-47.
- Pollard, Carl and Ivan A. Sag. 1994. *Head-Driven Phrase Structure Grammar*. University of Chicago Press.
- van Riemsdijk, Henk. 2000. Free Relatives Inside Out: Transparent Free Relatives as Grafts. In B. Rozwadowska (ed.), *PASE Papers in Language Studies: Proceedings of the 8th Annual Conference for the Study of English*. University of Wrocław.
- van Riemsdijk, Henk. 2001. A Far from Simple Matter: Syntactic Reflexes of Syntax-Pragmatics Misalignments. In I. Kenesei and R. M. Harnish (eds.) *Semantics, Pragmatics and Discourse: Perspectives and Connections: A Festschrift for Ferenc Kiefer*, 21-41. Amsterdam: John Benjamins.
- van Riemsdijk, Henk. 2006a. Free Relatives. In M. Everaert and H. v. Riemsdijk (eds.), *The Blackwell Companion to Syntax* Vol. II, 338-382. Blackwell.
- van Riemsdijk, Henk. 2006b. Grafts follow from Merge. In M. Frascarelli (ed.) *Phases of Interpretation, Studies in Generative Grammar* 91, 17-44. Berlin: Mouton de Gruyter.
- Wilder, Chris. 1999. Transparent Free Relatives. In K. N. Shahin et al. (eds.), *Proceedings of the Seventeenth West Coast Conference on Formal Linguistics*, 685-699. Stanford: CSLI Publications.
- Wright, Abby. and Andreas Kathol. 2003. When a Head is Not a Head: A Constructional Approach to Exocentricity in English. In J.-B. Kim and S. Wechsler (eds.), *Proceedings of the 9th International Conference on Head-driven Phrase Structure Grammar*, 373-389. CSLI Publications.